

## DISPOSABLE INSERT REBATING CUTTER BLOCKS

- Hard wearing steel and alloy body complete with disposable Tungsten Carbide knives (z) and scorers (v).
- Suitable for producing various thickness rebates in softwood, hardwood and man-made boards on a spindle moulder.
- Recommended RPM (n) 90mm diameter 8,500 – 12,000. 100mm diameter 7,600 – 12,900. 125mm diameter 6,100 – 10,000.
- Suitable for Hand Feeding (MAN).

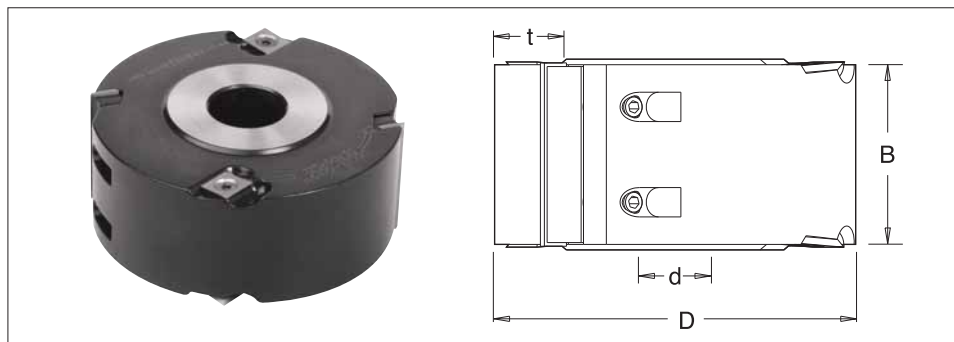
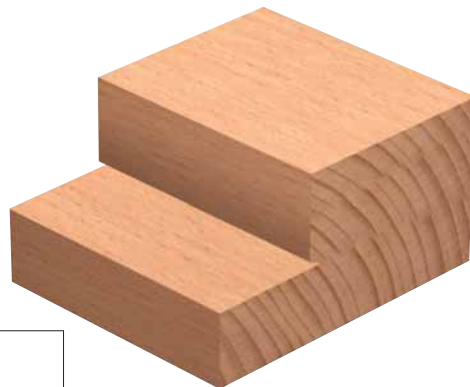

D	B	z	v	max. t	30mm Bore d	1 1/4" Bore d	Stock	Price
90	40	2	4	15	IT/733 201 1*	IT/733 201 7*	Y	£78.68
100	30	2	4	20	IT/733 105 1	IT/733 105 7	Y	£98.50
100	50	2	4	20	IT/733 106 1	IT/733 106 7	Y	£98.50
125	50	2	4	30	IT/733 302 1*	IT/733 302 7*	Y	£84.01
125	50	2	4	30	IT/733 102 1	IT/733 102 7	Y	£101.17
125	60	2	4	30	IT/733 103 1	IT/733 103 7	Y	£114.26

\* Hard wearing alloy body.

### SPARE KNIVES

Description	T.C. Blade				
	Product Ref.	IT/310 123 0/10	IT/300 052 8/10	IT/310 125 0/10	IT/300 053 1/10
Size	30x12x1.5 B=30mm	40x12x1.5 B=40mm	50x12x1.5 B=50mm	60x12x1.5 B=60mm	
Price	£22.48	£33.96	£33.96	£56.32	

### SPARE SCORER

Description	T.C. Blade
Product Ref.	IT/300 850 3/10
Size	14x14x2 B=30-60mm
Price	£22.48

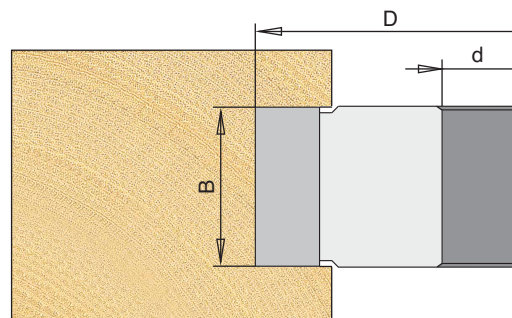
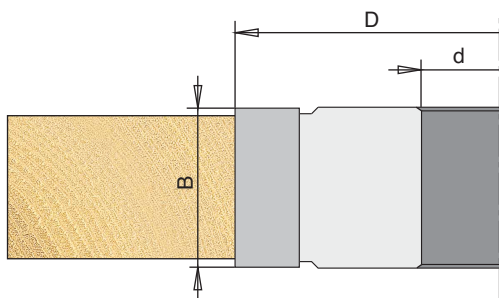

### KEY

Spare Knives and Scorers - Product Reference ending in /10 are sold in packs of ten.

Stock - Y means normally kept in stock for next day delivery.

N means not normally held in stock, delivery in a short time.