

ADJUSTABLE THIN KERF GROOVING CUTTERS 24 TEETH 1.5-6.0MM

- Hard wearing steel body 'sawblade' style groover with 24 Tungsten Carbide teeth.
- Suitable for producing various width grooves and slots in softwood, hardwood and man-made board on a spindle moulder.
- Cutting width can be adjusted by 0.1mm by using supplied spacer rings.
- Special grinding shape on teeth for extremely clean cut.
- Same tool body suits both 1.5 - 3.0mm and 3.0 - 6.0mm groovers.
- Recommended RPM (n) 8,000.
- Suitable for hand feeding (MAN).

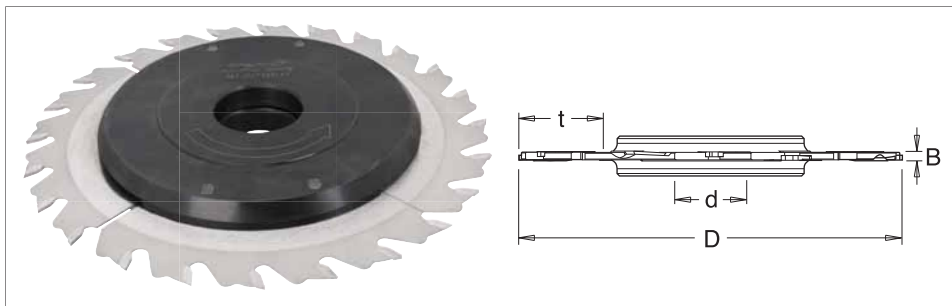
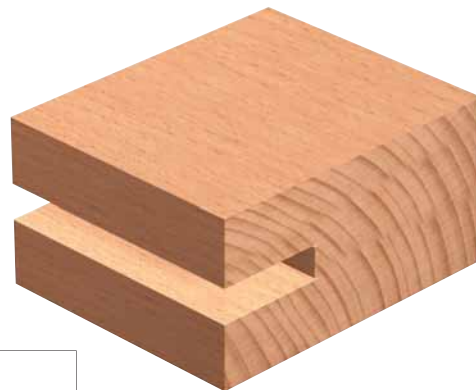

D	B	z	max. t	30mm Bore d	1 1/4" Bore d	Stock	Price
160	1.5 - 3.0	24	25	IT/712 314 1	IT/712 314 7	Y	£176.00
160	3.0 - 6.0	24	25	IT/712 218 1	IT/712 218 7	Y	£176.00

SPARE KNIVES

Description	T.C. Blade	
	Product Ref.	IT/712 217 8
Size	160x1.5 B=1.5 - 3.0mm	160x3.0 B=3.0 - 6.0mm
Price	£56.94	£61.08

SPARE TOOL BODY inc. Spacers

Description	Tool Body	
	Product Ref.	IT/712 440 1
Size	110x30 B=1.5 - 6.0mm	110x1-1/4" B=1.5 - 6.0mm
Price	£148.05	£148.05

SPARE PARTS

Hex Screw	Hex Key
IT/193 078 5	IT/194 003 4
M5 x 10	S3
£1.61	£5.10

Ref. IT/712 314 1

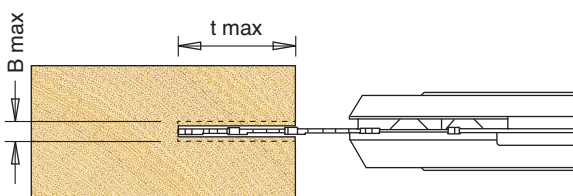

Ref. IT/712 218 1

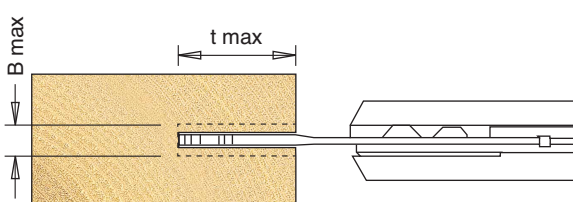

KEY

Stock - Y means normally kept in stock for next day delivery.
N means not normally held in stock, delivery in a short time.