

NON-FERROUS SAWBLADES

- Suitable for trimming with a medium/fine finish on solid aluminium bars.
- Triple chip tooth.
- Material must be firmly clamped on both sides of cut and sawblade should be lubricated during use.
- For use on mitre, double cross-cutting and sizing machines.
- Other bore sizes available, see page 17.

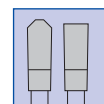

**ALUMINIUM
TRIPLE CHIP TEETH
MEDIUM/FINE FINISH**

TCT

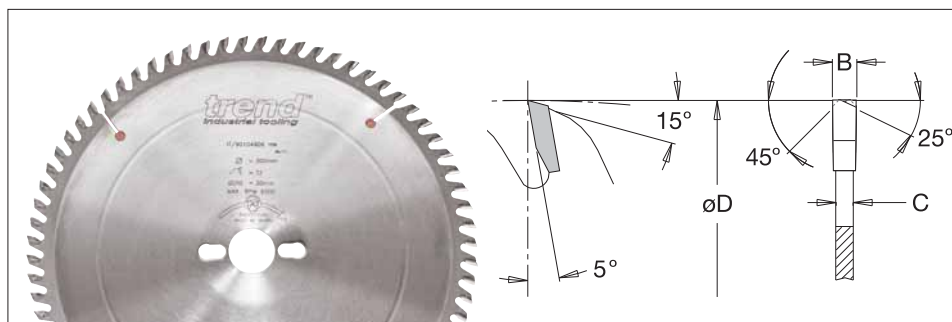

øD	Teeth	B	C	ø bore	Product Ref.	Stock	Price
300	60	3.4	2.8	30	IT/902 50 10 6	N	£125.16
300	80	3.4	2.8	30	IT/902 54 00 6	N	£147.16
350	80	3.6	3.0	30	IT/902 50 20 6	N	£159.91
350	100	3.6	3.0	30	IT/902 54 30 6	N	£183.10
400	80	3.8	3.2	30	IT/902 50 30 6	N	£177.31
400	120	3.8	3.2	30	IT/902 54 50 6	N	£197.00
450	80	4.0	3.4	30	IT/902 56 00 6	N	£210.91
450	100	4.0	3.4	30	IT/902 50 40 6	N	£220.17
500	80	4.2	3.5	30	IT/902 56 03 6	N	£232.92
500	100	4.2	3.5	30	IT/902 50 50 6	N	£259.57
550	100	4.4	3.8	30	IT/902 56 06 6	Y	£318.68
550	120	4.4	3.8	30	IT/902 50 60 6	Y	£327.95

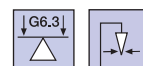

KEY

Stock - Y means normally kept in stock for next day delivery.

N means not normally held in stock, delivery in a short time.