

PANEL TRIMMING & SIZING SAWBLADES FOR USE WITH SCORERS

- Suitable for trimming and cross cutting with a medium to fine finish on single-sided laminated boards (chipboard, MDF etc).
- Triple chip tooth.
- For use on a table or panel saw.
- Marked blades are **T-MAX** quality for long lasting durability.
- Other bore sizes available, see page 17.

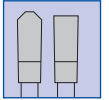

BOARDS & LAMINATED BOARDS
TRIPLE CHIP TEETH
MEDIUM/FINE FINISH

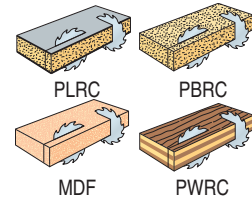
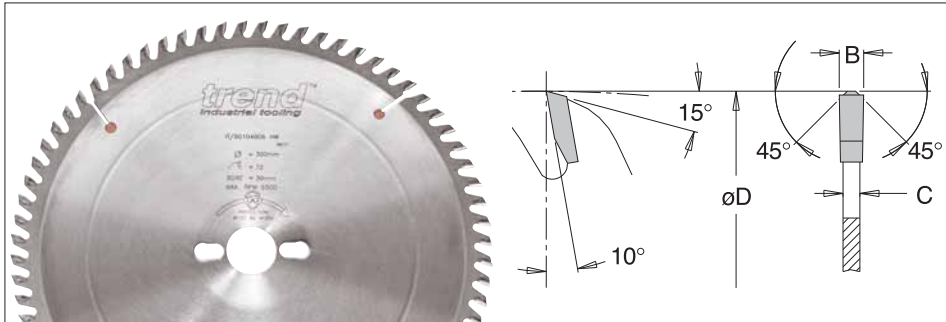

øD	Teeth	B	C	ø bore	Product Ref.	Stock	Price
200	64	3.0	2.0	30	IT/901 06 08 6	Y	£88.07
220	64	3.0	2.0	30	IT/901 06 12 6	Y	£93.29
250	40	3.2	2.2	30	IT/901 04 75 6	Y	£73.00
250	60	3.2	2.2	30	IT/901 04 80 6	N	£85.88
250	T-MAX 60	3.2	2.2	30	IT/950 04 80 6	Y	£104.07
250	80	3.2	2.2	30	IT/901 06 10 6 *	Y	£91.90
250	T-MAX 80	3.2	2.2	30	IT/950 06 10 6	Y	£120.52
300	60	3.2	2.2	30	IT/901 04 85 6	N	£91.90
300	72	3.2	2.2	30	IT/901 04 90 6 *	Y	£103.48
300	T-MAX 72	3.2	2.2	30	IT/950 04 90 6	Y	£127.24
300	96	3.2	2.2	30	IT/901 06 20 6 *	Y	£107.76
300	T-MAX 96	3.2	2.2	30	IT/950 06 20 6	Y	£141.15
350	72	3.5	2.5	30	IT/901 04 95 6	N	£111.37
350	T-MAX 72	3.5	2.5	30	IT/950 04 95 6	Y	£136.27
350	84	3.5	2.5	30	IT/901 05 00 6 *	Y	£127.24
350	T-MAX 84	3.5	2.5	30	IT/950 05 00 6	Y	£154.58
350	108	3.5	2.5	30	IT/901 06 30 6 *	Y	£140.57
350	T-MAX 108	3.5	2.5	30	IT/950 06 30 6	Y	£163.05
400	96	3.5	2.5	30	IT/901 05 10 6 *	Y	£140.76
400	120	3.5	2.5	30	IT/901 06 40 6 *	Y	£167.33
450	66	4.0	2.8	30	IT/901 02 98 6	Y	£149.71
450	132	4.0	2.8	30	IT/901 06 41 6 *	Y	£193.52
500	120	4.4	3.0	30	IT/901 05 17 6 *	Y	£217.86

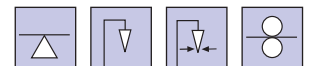

KEY

Stock - Y means normally kept in stock for next day delivery.
 N means not normally held in stock, delivery in a short time.

MANUFACTURING TECHNOLOGY

