

MAX THE ULTIMATE SAWING BLADES

- Special dynamic balancing.
- Unique straightening operation.
- Long-lasting quality cut.
- Low noise level.
- Every panel saw documented with full traceability.
- Increased sharpness compared to industry standard.

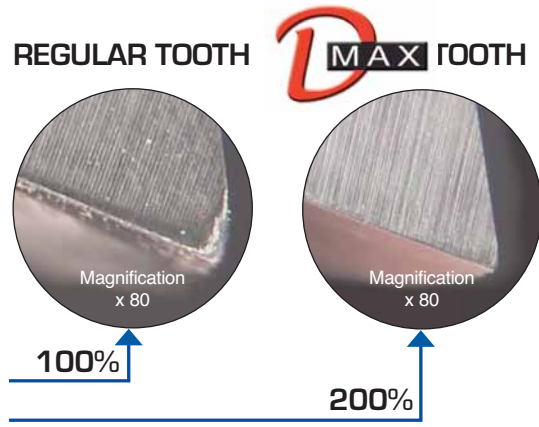

TRIMMING AND SIZING SAWBLADES

- Suitable for trimming and sizing cross cutting with a fine finish on solid soft, hard woods and man-made veneered boards.
- Alternate bevel tooth.
- For use on a table saw.
- Marked blades are **MAX** quality for long lasting durability.
- Other bore sizes available, see page 17.

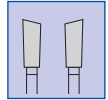

BOARDS & VENEERED BOARDS ALTERNATE BEVEL TEETH FINE FINISH

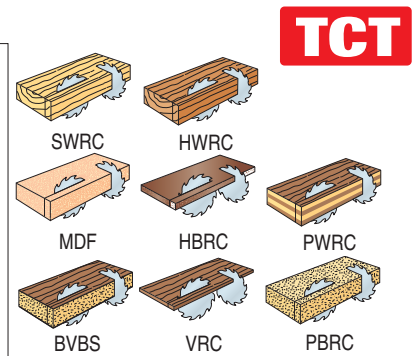
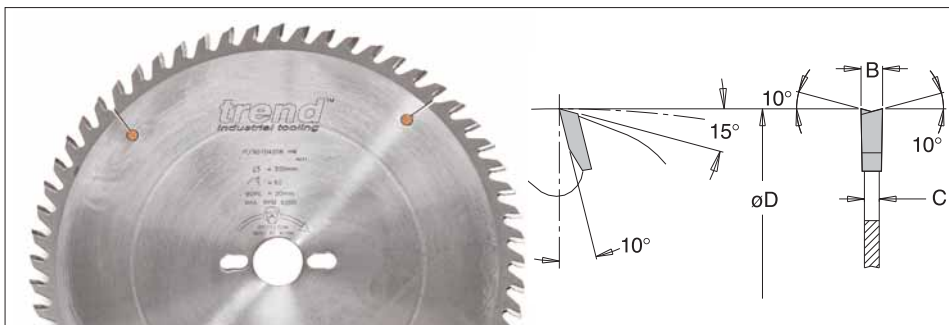

| øD | Teeth | B | C | ø bore | Product Ref. | Stock | Price |
|----------------|-------|-----|-----|--------|-----------------|-------|---------|
| 200 | 64 | 3.0 | 2.0 | 30 | IT/901 05 50 6 | Y | £79.95 |
| 250 | 60 | 3.2 | 2.2 | 30 | IT/901 04 10 6 | Y | £79.73 |
| 250 MAX | 60 | 3.2 | 2.2 | 30 | IT/950 04 10 6 | N | £95.61 |
| 250 | 80 | 3.2 | 2.2 | 30 | IT/901 05 70 6 | Y | £91.90 |
| 250 MAX | 80 | 3.2 | 2.2 | 30 | IT/950 05 70 6 | N | £113.22 |
| 300 | 60 | 3.2 | 2.2 | 30 | IT/901 04 20 6 | Y | £85.88 |
| 300 | 72 | 3.2 | 2.2 | 30 | IT/901 04 30 6 | Y | £96.76 |
| 300 MAX | 72 | 3.2 | 2.2 | 30 | IT/950 04 30 6 | Y | £118.10 |
| 300 | 96 | 3.2 | 2.2 | 30 | IT/901 05 80 6 | Y | £108.35 |
| 300 MAX | 96 | 3.2 | 2.2 | 30 | IT/950 05 80 6 | N | £132.10 |
| 315 | 72 | 3.2 | 2.2 | 30 | IT/SB/901 00 26 | Y | £114.73 |
| 350 | 72 | 3.5 | 2.5 | 30 | IT/901 04 40 6 | Y | £104.07 |
| 350 MAX | 72 | 3.5 | 2.5 | 30 | IT/950 04 40 6 | Y | £127.24 |
| 350 | 84 | 3.5 | 2.5 | 30 | IT/901 04 50 6 | Y | £118.10 |
| 350 MAX | 84 | 3.5 | 2.5 | 30 | IT/950 04 50 6 | N | £144.28 |
| 350 | 108 | 3.5 | 2.5 | 30 | IT/901 05 90 6 | Y | £130.83 |
| 350 MAX | 108 | 3.5 | 2.5 | 30 | IT/950 05 90 6 | N | £160.05 |
| 400 | 96 | 3.5 | 2.5 | 30 | IT/901 04 60 6 | Y | £135.70 |
| 400 | 120 | 3.5 | 2.5 | 30 | IT/901 06 00 6 | Y | £156.43 |
| 450 | 132 | 4.0 | 2.8 | 30 | IT/901 06 03 6 | Y | £180.78 |
| 500 | 120 | 4.4 | 3.0 | 30 | IT/901 04 63 6 | Y | £202.69 |

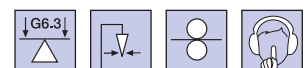

MANUFACTURING TECHNOLOGY

- Balance
- Dynamic Balance
- Straightening
- Dynamic Straightness
- Tension
- Low Noise

