

RIP SAWBLADES WITH COOLING SLOTS

- Suitable for rip cutting with a coarse finish on solid soft and hard woods.
- Flat tooth with large gullet for fast chip removal and chip limiters to reduce kick-back.
- Cooling slots to prevent blade overheating.
- For use on a bench, table or rip saw.
- Other bore sizes available, see page 17.

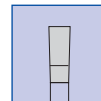

**SOLID WOOD
FLAT TEETH
COARSE FINISH**

TCT

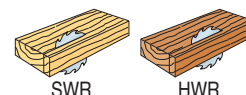
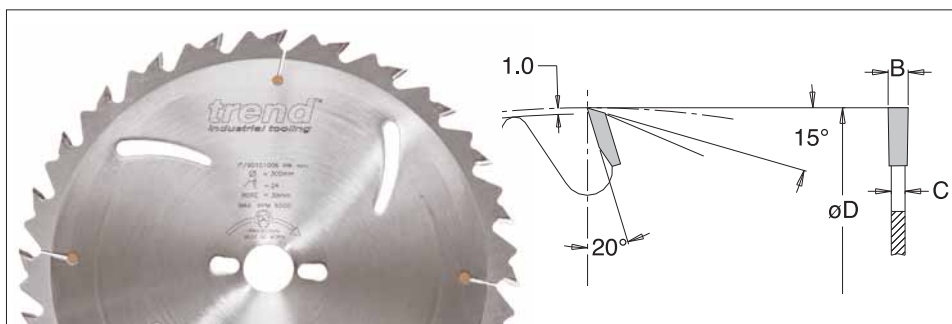

øD	Teeth	B	C	ø bore	Product Ref.	Stock	Price
250	24	3.2	2.2	30	IT/901 00 95 6	Y	£55.39
300	24	3.2	2.2	30	IT/901 01 00 6	Y	£65.71
300	28	3.2	2.2	30	IT/901 01 04 6	Y	£69.99
315	24	3.2	2.2	30	IT/901 01 08 6	Y	£69.98
350	32	3.5	2.5	30	IT/901 01 13 6	Y	£88.31
400	28	3.5	2.5	30	IT/901 01 15 6	Y	£90.05
450	40	4.0	2.8	30	IT/901 01 16 6	Y	£124.11
500	44	4.4	3.0	30	IT/901 01 18 6	Y	£149.71

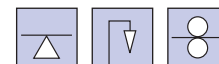

CROSS CUT SAWBLADES

- Suitable for cross cutting with a coarse finish to fine finish on solid soft and hard woods.
- Alternate bevel tooth with zero or negative degree angle to minimise material 'pick-up' or 'snatching'.
- For use on a radial arm or mitre saw.
- Other bore sizes available, see page 17.

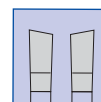

**SOLID WOOD
ALTERNATE BEVEL TEETH
MEDIUM/FINE FINISH**

TCT

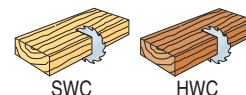
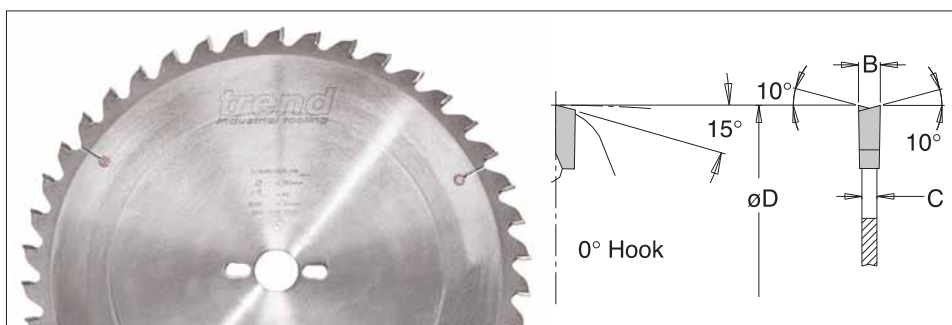

øD	Teeth	B	C	ø bore	Product Ref.	Stock	Price
215	48	2.8	1.8	30	IT/912 04 11 6	Y	£73.00
215	60	2.8	1.8	30	IT/912 05 45 6	Y	£82.28
250	24	3.4	2.4	30	IT/908 01 10 6	Y	£63.26
250	42	3.4	2.4	30	IT/908 01 20 6	Y	£101.63
250	72	3.2	2.4	30	IT/901 40 60 6	N	£91.90
300	36	3.8	2.8	30	IT/908 01 30 6	Y	£88.31
305	48	3.2	2.2	30	IT/SB/912 00 36	Y	£78.80
350	42	4.2	2.8	30	IT/908 01 50 6	Y	£107.76
400	48	4.2	3.0	30	IT/908 01 70 6	Y	£122.97

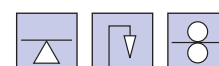

**MANUFACTURING
TECHNOLOGY**



Balance



Dynamic
Balance



Straightening



Dynamic
Straightness



Tension



Low
Noise

trend
routing technology