

RIP SAWBLADES

- Suitable for rip cutting with a coarse finish on solid soft and hard woods.
- Flat tooth with large gullet for fast chip removal.
- For use on a bench, table or rip saw.
- Other bore sizes available, see page 17.

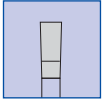

**SOLID WOOD
FLAT TEETH
COARSE FINISH**

TCT

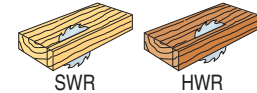
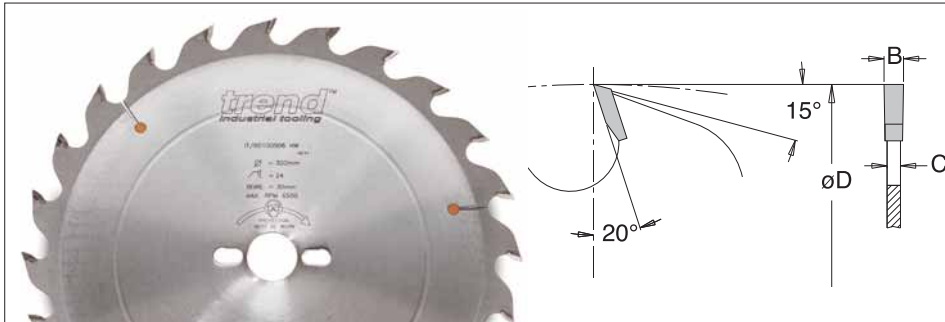

øD	Teeth	B	C	ø bore	Product Ref.	Stock	Price
250	20	3.2	2.2	30	IT/901 00 30 6	N	£45.08
250	24	3.2	2.2	30	IT/901 00 40 6	Y	£46.93
300	24	3.2	2.2	30	IT/901 00 50 6	Y	£55.98
300	30	3.2	2.2	30	IT/901 00 60 6	Y	£62.12
350	28	3.5	2.5	30	IT/901 00 70 6	Y	£69.98
400	32	3.5	2.5	30	IT/901 00 80 6	Y	£80.48
450	32	4.0	2.8	30	IT/901 00 84 6	Y	£90.46
500	36	4.4	3.0	30	IT/901 00 85 6	Y	£110.39

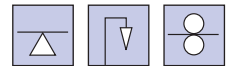

RIP SAWBLADES - THICKER TIP & PLATE

- Suitable for rip cutting with a coarse finish on solid soft and hard woods.
- Thicker Tungsten Carbide Tips and saw body for heavy duty applications.
- For use on a bench, table or rip saw.
- Other bore sizes available, see page 17.

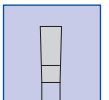

**SOLID WOOD
FLAT TEETH
COARSE FINISH**

TCT

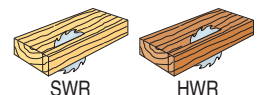
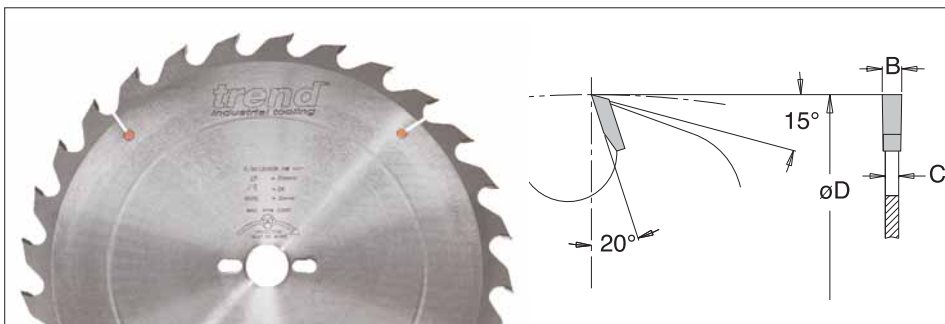

øD	Teeth	B	C	ø bore	Product Ref.	Stock	Price
300	24	4.0	2.8	30	IT/901 20 20 6	N	£73.00
300	24	4.4	2.8	30	IT/901 20 30 6	N	£73.00
350	28	4.0	2.8	30	IT/901 20 60 6	N	£88.88
350	28	4.4	2.8	30	IT/901 20 50 6	Y	£88.88
400	32	4.0	3.0	30	IT/901 21 10 6	N	£101.63
400	32	4.4	3.0	30	IT/901 20 90 6	N	£101.63

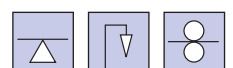

KEY

Stock - Y means normally kept in stock for next day delivery.

N means not normally held in stock, delivery in a short time.