

TCT Ogee Cutters

TCT
TUNGSTEN
CARBIDE
TIPPED

OGEE PANEL

Small panelling cutters, popular for decorative cupboard doors and furniture embellishments.

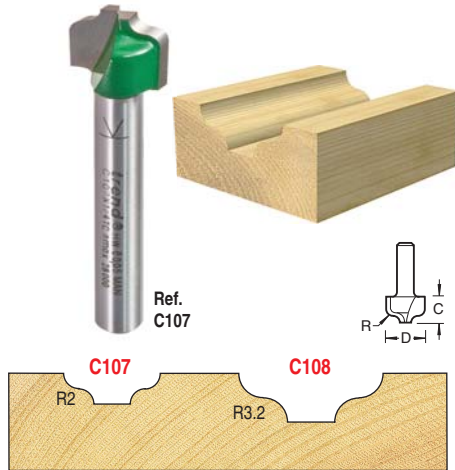

R mm	D mm	C mm	Product Ref.	Shank Diameter
2.0	12.7	9.5	C107	1/4"
3.2	19.1	11.1	C108	8mm

CLASSIC DECOR

To create profiles on face or edge of drawer fronts and cabinet doors.

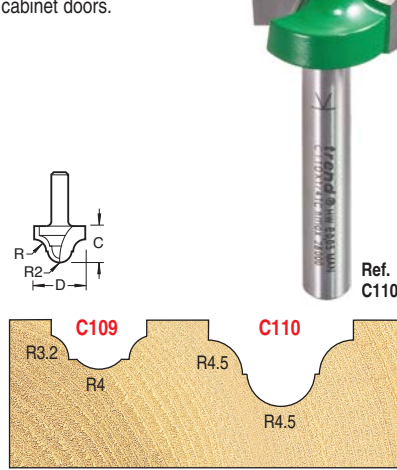

R mm	R2 mm	D mm	C mm	Product Ref.	Shank Diameter
3.2	4.0	12.7	9.5	C109	1/4"
4.5	4.5	19.1	14.0	C110	8mm

OGEE MOULD

For panel and veining work. Ideal for barley twists using the discontinued Trend Routerlathe.

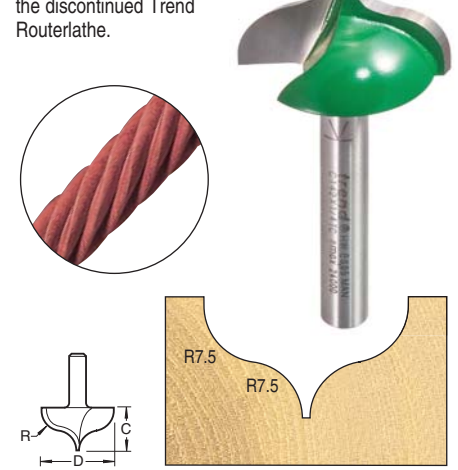

R mm	D mm	C mm	Product Ref.	Shank Diameter
7.5	27.0	16.0	C142	1/4" 8mm

SHANK MOUNTED BEARING GUIDED CLASSIC DECOR

Ideal for following templates. It is advisable that the template is at least 5mm thicker than the cut length of tool.

Ideal for solid panel wardrobe doors.

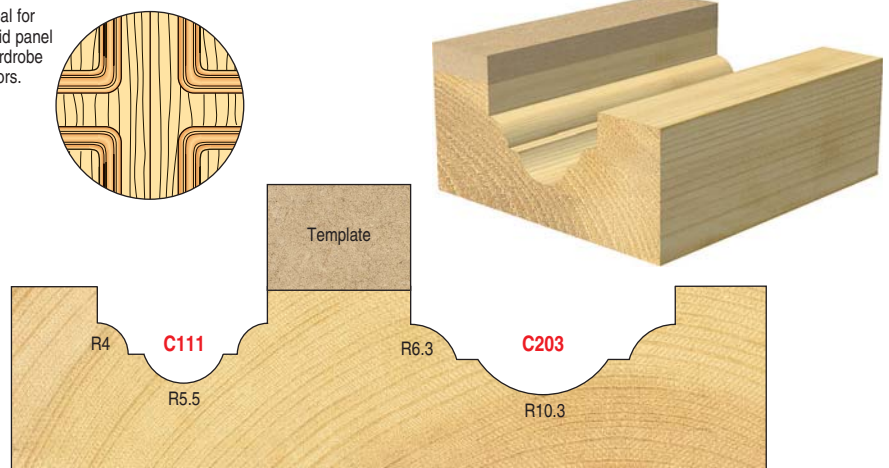

R mm	R2 mm	D mm	C mm	B mm	Product Ref.	Shank Diameter
4.0	5.5	22.0	12.7	22.0	C111	1/4" 8mm 1/2"
6.3	10.3	35.0	14.3	35.0	C203	- - £45.76

SHANK MOUNTED BEARING GUIDED CLASSIC PANEL

Ideal for following templates. It is advisable that the template is at least 5mm thicker than the cut length of tool.

Ideal for drawer fronts.

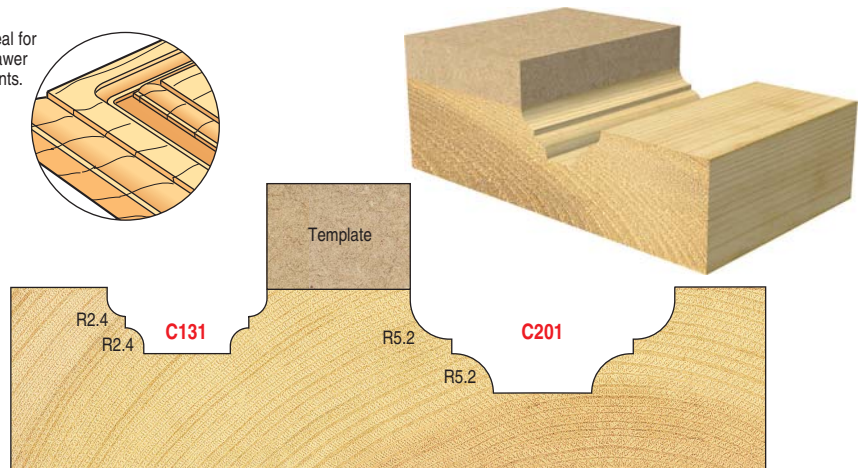

R mm	D mm	C mm	B mm	Product Ref.	Shank Diameter
2.4	22.0	10.0	22.0	C131	1/4" 8mm 1/2"
5.2	35.0	14.0	35.0	C201	- - £45.76

BEARING GUIDED OGEE MOULD

Supplied with an extra 3/8" bearing to create a lower quirk.

Applications for Bearing Guided Cutters

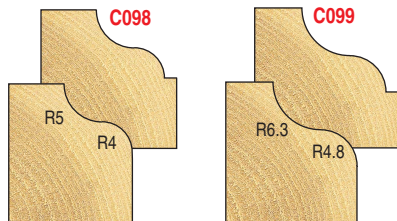

	R mm	R2 mm	C mm	B mm	B2 mm	Product Ref.	Shank Dia. 1/4"	Shank Dia. 8mm
	5.0	4.0	12.7	9.5	12.7	C098	£40.09	£40.09
	6.3	4.8	17.5	9.5	12.7	C099	£41.41	£41.41

BEARING GUIDED BROKEN OGEE

Supplied with an extra 3/8" bearing to create a lower quirk.

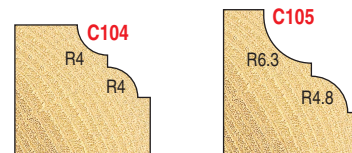
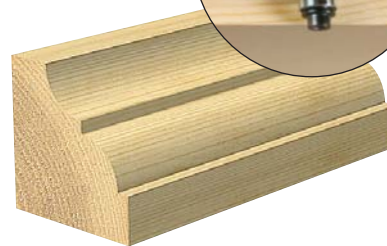

	R mm	R2 mm	C mm	B mm	B2 mm	Product Ref.	Shank Dia. 1/4"	Shank Dia. 8mm
	4.0	4.0	12.7	9.5	12.7	C104	£41.41	-
	6.3	4.8	17.5	9.5	12.7	C105	£47.11	£47.11

BEARING GUIDED ROMAN OGEE

By raising the cutter, the top quirk is removed.

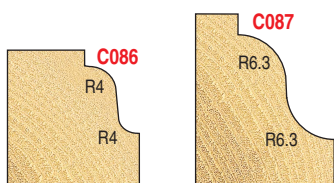
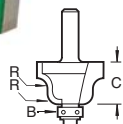

	R mm	C mm	B mm	Product Ref.	Shank Diameter 1/4"	Shank Diameter 8mm	Shank Diameter 1/2"
	4.0	15.9	9.5	C086	£37.54	£37.54	£37.54
	6.3	20.0	9.5	C087	£41.41	-	-

BEARING GUIDED CLASSIC OGEE

Versatile cutters, using all or part of the cutter.

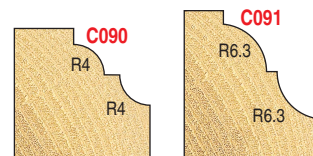
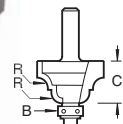

	R mm	C mm	B mm	Product Ref.	Shank Dia. 1/4"	Shank Dia. 8mm
	4.0	15.9	9.5	C090	£38.16	£38.16
	6.3	15.9	9.5	C091	£38.88	£38.88

BEARING GUIDED OGEE QUIRK

By raising the cutter, the top quirk is removed. Supplied with an extra 3/8" bearing to create a lower quirk.

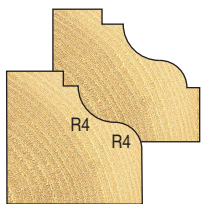
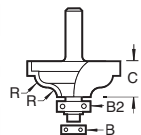

	R mm	C mm	B mm	B2 mm	Product Ref.	Shank Dia. 1/4"	Shank Dia. 8mm
	4.0	13.5	9.5	12.7	C096	£40.09	£40.09

BEARING GUIDED ELEGANT MOULD

Wide combination moulds for edging table tops and shelves.

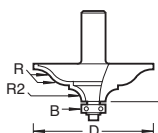
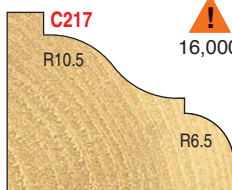
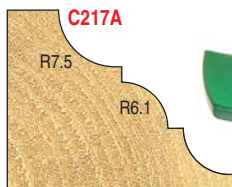

	R mm	R2 mm	D mm	C mm	B mm	Product Ref.	Shank Dia. 1/2"
	10.5	6.5	63.0	20.0	12.7	C217	£73.12
	7.5	6.1	63.0	20.0	12.7	C217A	£88.89