

# RAISED PANEL MOULDING

**TCT**  
TUNGSTEN  
CARBIDE  
TIPPED



[trend-uk.com/video](http://trend-uk.com/video)

- Traditional panels and frame doors, formerly machined on spindle moulders, can now be produced using heavy duty routers mounted in fixed positions, either overhead or inverted.
  - These raised panel cutters run best at lower speeds and match our range of profile scribers.
  - All suitable for use on natural timber and MDF.
- ⚠ Router table or overhead router use only.

## RADIUSED RAISED PANEL MOULDER

Suitable panel mould for use with Ref. PSC/2



⚠ 18,000

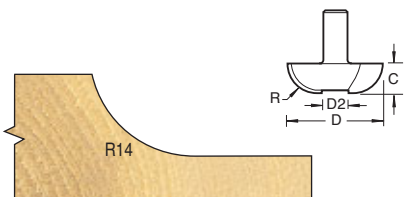

R mm	D mm	D2 mm	C mm	Product Ref.	Shank Dia. 1/2"
14.0	50.0	22.0	14.0	18/21	£84.82

## BEARING GUIDED LARGE RADIUSED PANEL RAISER

Suitable panel mould for use with Ref. PSC/40.



⚠ 12,000

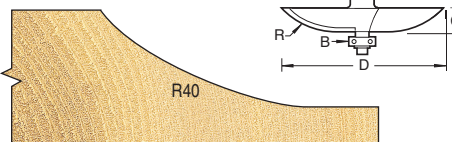

R mm	D mm	C mm	B mm	Product Ref.	Shank Dia. 1/2"
40.0	86.0	12.7	12.7	18/81	£95.43

## BEARING GUIDED LARGE Ogee PANEL RAISER

Suitable panel mould for use with Ref. PSC/2.

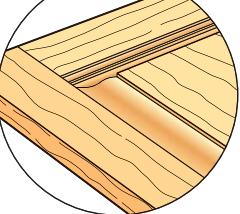
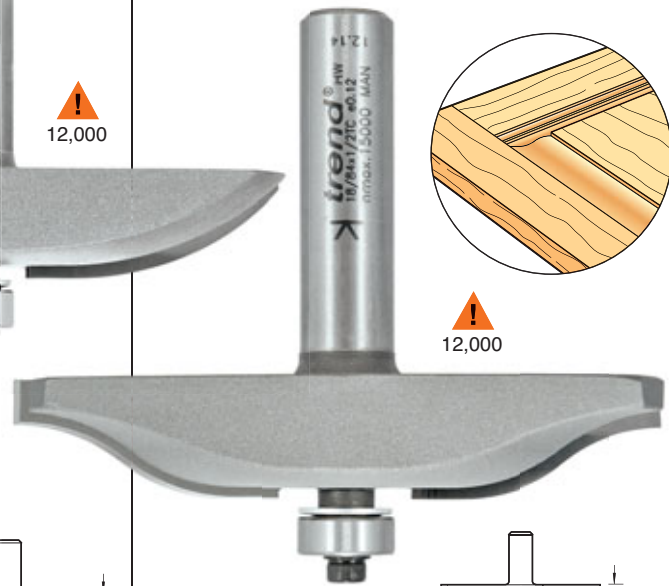

⚠ 12,000

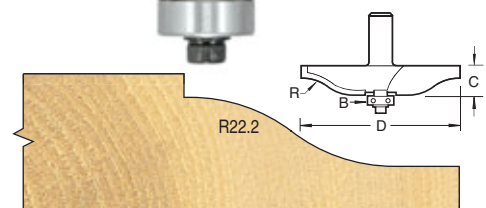

R mm	D mm	C mm	B mm	Product Ref.	Shank Dia. 1/2"
22.2	85.7	15.9	12.7	18/84	£95.43