

# EDGE MOULDING

PROFESSIONAL ROUTER CUTTERS



## TRADITIONAL TORUS

Classic skirting board mould.

⚠ 22,000

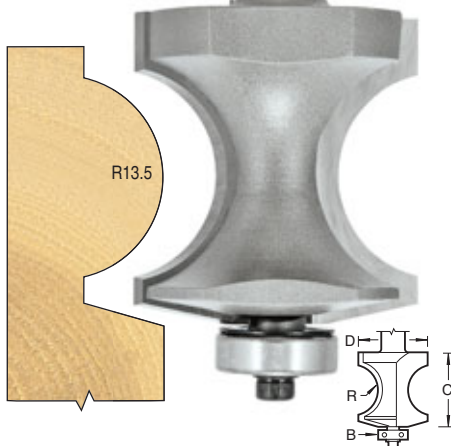

R mm	D mm	C mm	B mm	Product Ref.	Shank Dia. 1/2"
13.5	37.0	40.0	16.0	90/12	£84.82

## MODERN TORUS

Modern torus skirting board mould.

⚠ 22,000

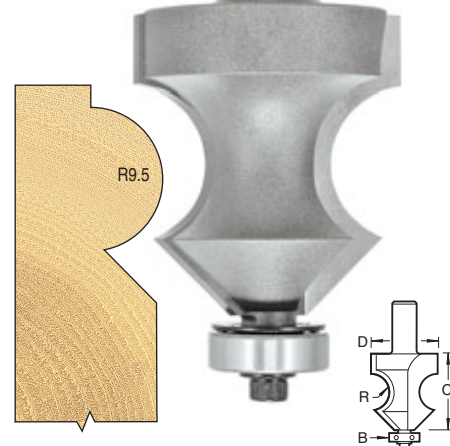

R mm	D mm	C mm	B mm	Product Ref.	Shank Dia. 1/2"
9.5	35.0	39.0	16.0	90/13	£84.82

## VICTORIAN TORUS

Classic skirting board mould with a curved return to the edge.

⚠ 22,000

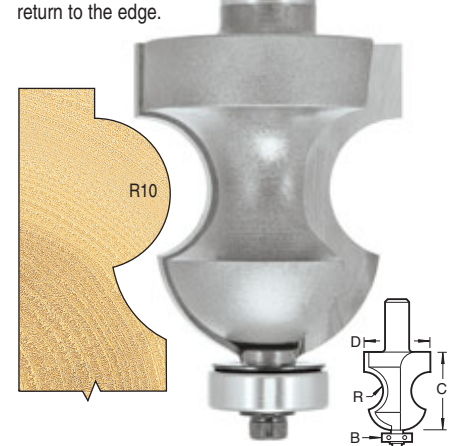

R mm	D mm	C mm	B mm	Product Ref.	Shank Dia. 1/2"
10.0	35.0	41.0	16.0	90/14	£84.82

## CORNICE CUTTER

Two cutters for producing different types of cornice. Chamfers can be routed using a 45° cutter eg. Ref. 46/38. These cutters can also be used to produce a matching dado rail. For edge moulding only.

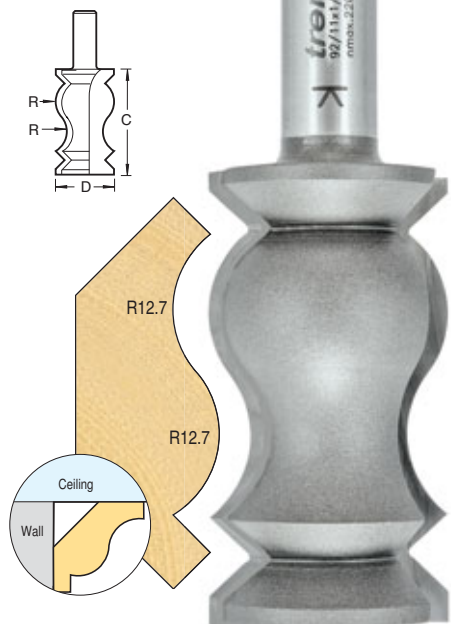

R mm	D mm	C mm	Product Ref.	Shank Dia. 1/2"
12.7	32.0	58.0	92/11	£63.60

## BEARING GUIDED DECORATIVE BEAD

Classic cutters for bolection moulds, used on panelled doors or heavy cornice work. Also for architraves, framing as well as edge moulding.

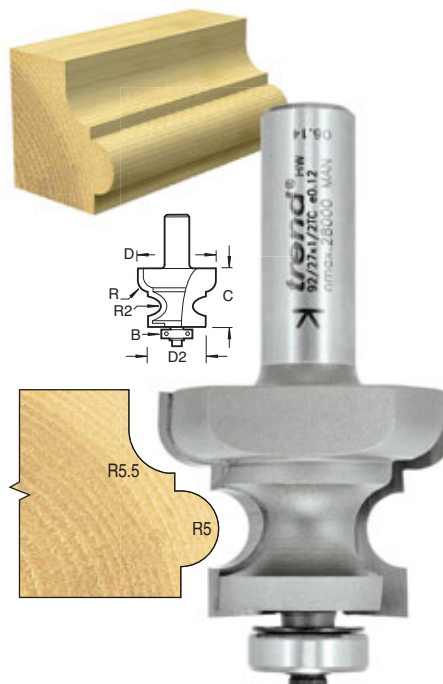

R mm	R2 mm	D mm	D2 mm	C mm	B mm	Product Ref.	Shank Dia. 1/2"
5.5	5.0	40.0	26.0	30.0	16.0	92/27	£65.88 +

## ROMAN OGEE EDGE MOULD

Ideal for edging traditional picture frames, mirrors, clocks and plaques.

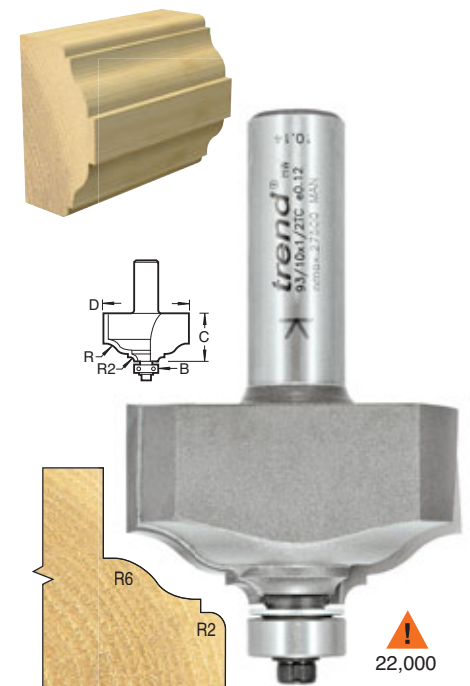

R mm	R2 mm	D mm	C mm	B mm	Product Ref.	Shank Dia. 1/2"
6.0	2.0	45.0	25.4	12.7	93/10	£65.37 +

⚠ For stationary machines at max. recommended speeds as indicated.

+ While stocks last