

# JOINTING CUTTERS



## BEARING GUIDED FINGER JOINTER SET 866



**INST**  
Instructions supplied

Ref. 866 Finger Jointer combines an assembly of five TCT slotting cutters with an abutting-edge cutter to produce a profile that extends the glue line threefold, resulting in an extremely strong joint. It fits into any portable or stationary router with a 1/2" collet.

**Performing the cut**  
Timber must be machined square. The cutters should be assembled to match the spindle rotation, and be stacked at 90° to one another to ease stress on the tool.

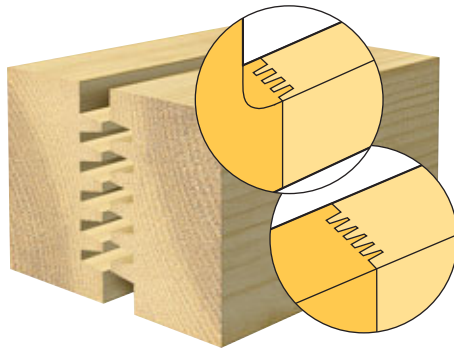

**Timber thickness**  
Min. 11.0mm (7/16")  
Max. 36.0mm (1-3/8")

**Fitted with 1 cutter**  
**Timber thickness**  
Min. 11.0mm (7/16")  
Max. 16.0mm (5/8")

**Fitted with 5 cutters**  
**Timber thickness**  
Min. 31.0mm (1-3/16")  
Max. 36.0mm (1-3/8")

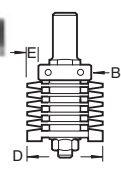
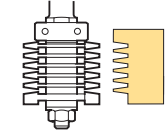
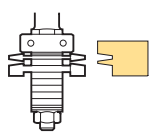

D mm	E mm	B mm	OL mm	Product Ref.	Shank Diameter
40.0	6.0	28.0	96.0	<b>866</b>	1/2"

## BEARING GUIDED FINGER JOINTER SET 865



A bearing guided reversible finger jointer, to increase the gluing area for edge to edge joints.

**Timber thickness**  
Min. 11.0mm  
Max. 26.0mm

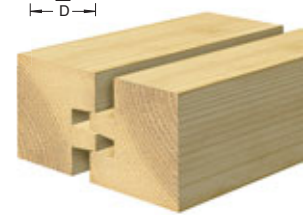
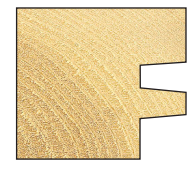
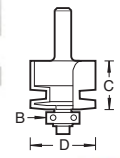

D mm	C mm	B mm	Product Ref.	Shank Dia.
24.6	18.5	12.7	<b>865</b>	1/4"

## BEARING GUIDED COMB JOINTER SET 876

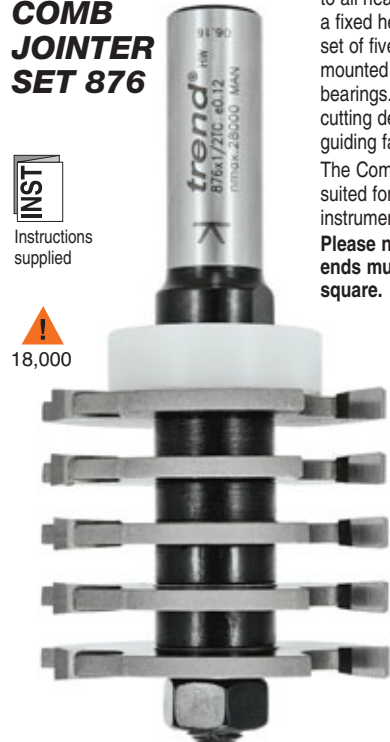

**INST**  
Instructions supplied

This Comb Jointing Set can be fitted to all heavy duty routers mounted in a fixed head position. It comprises a set of five 4mm kerf, TCT groovers, mounted on an arbor and three ball bearings. These offer alternative cutting depths and provide a self-guiding facility.

The Comb Jointer is ideally suited for producing small boxes, instrument cases etc.

**Please note, timber ends must be cut square.**

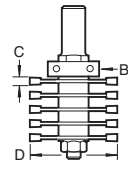
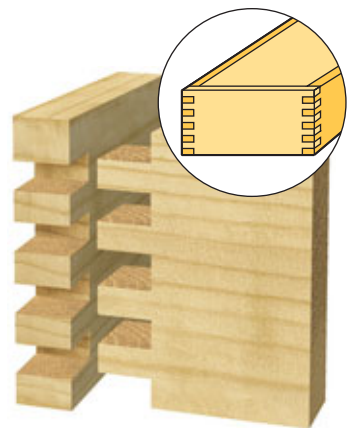

**Timber width**  
Max. 40.0mm

D mm	C mm	B mm	OL mm	Product Ref.	Shank Diameter
47.6	4.0	28.0	96.0	<b>876</b>	1/2"

Timber Thickness					
Bearing 34mmØ	up to 6.5mm	<b>BB34</b>	£14.96		
Bearing 29mmØ	6.6mm to 9.0mm	<b>BB29</b>	£14.96		
Bearing 28mmØ	9.1mm to 9.5mm	<b>BB28</b>	£14.96		
Spacer 8mm bore x 5.3mm thick		<b>SPAC/8/53</b>	£1.84 (each)		

## OFFSET TONGUE & GROOVER

A heavy duty reversible finger jointer, to increase the gluing area for edge to edge joints.



**Timber thickness**  
Min. 14.0mm  
Max. 25.0mm

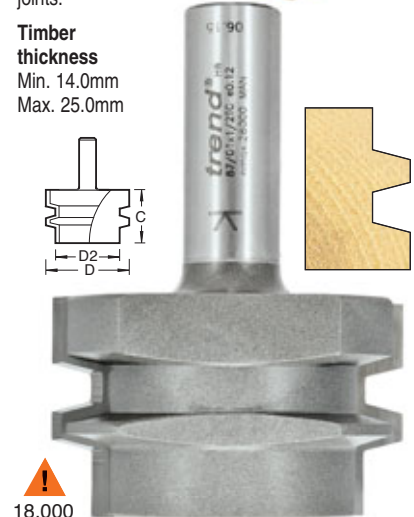
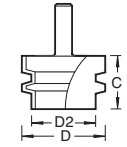

**!**  
18,000

D mm	D2 mm	C mm	Product Ref.	Shank Dia.
47.5	37.0	30.0	<b>8701</b>	1/2"