

# CHAMFER & 'V' GROOVE

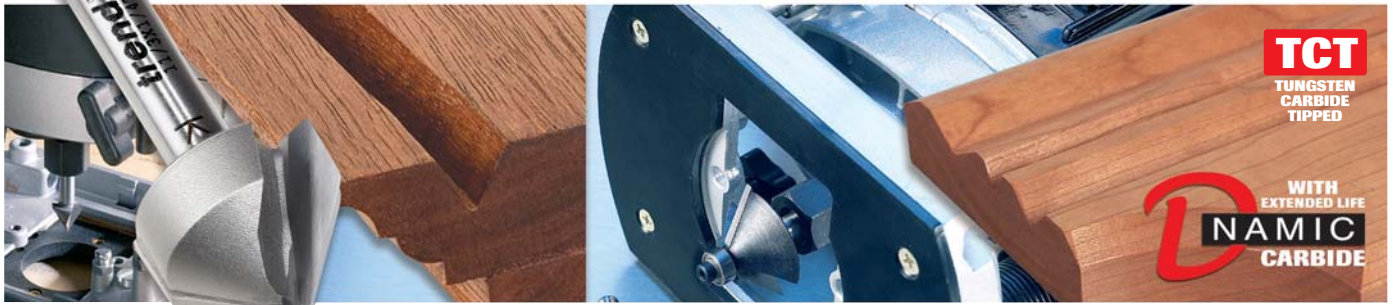

## THREE FLUTE ENGRAVER

Cuts cleanly without feather edging. Solid Carbide for long life. Cuts to a fine 'V' groove point. Ideal for sign writing.

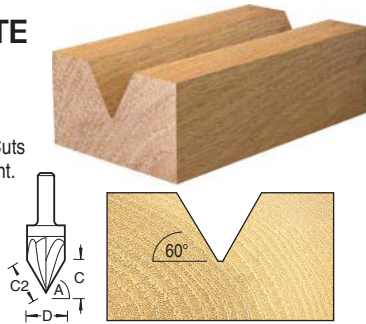

A Deg.	D mm	C mm	C2 mm	Product Ref.	Shank Diameter 1/4"	Shank Diameter 8mm
60°	14.5	12.5	14.0	S11/11	£54.74	£54.74



## STC ENGRAVER

Solid Carbide for long life. Ideal for engraving and veining work.



Ref. S11/01

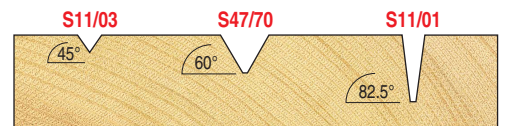
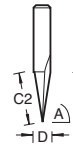

A Deg.	D mm	C mm	C2 mm	Product Ref.	Shank Diameter 3mm	Shank Diameter 1/4"
45°	3.0	3.0	-	S11/03	£24.83	-
60°	6.3	6.0	6.0	S47/70	-	£26.76
82.5°	5.0	15.0	16.0	S11/01	-	£39.49

## CHAMFER 'V' GROOVE

Use for bevelling, chamfering and for producing mortar grooves. Approx. 1.0mm flat will be found on nose. Ref. 11/3 is ideal for imitating 'V' jointed tongue and groove on man-made board.

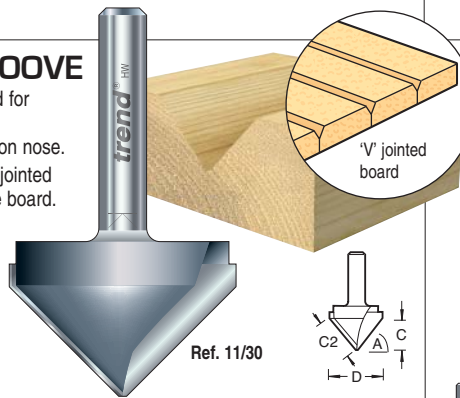

Ref. 11/30

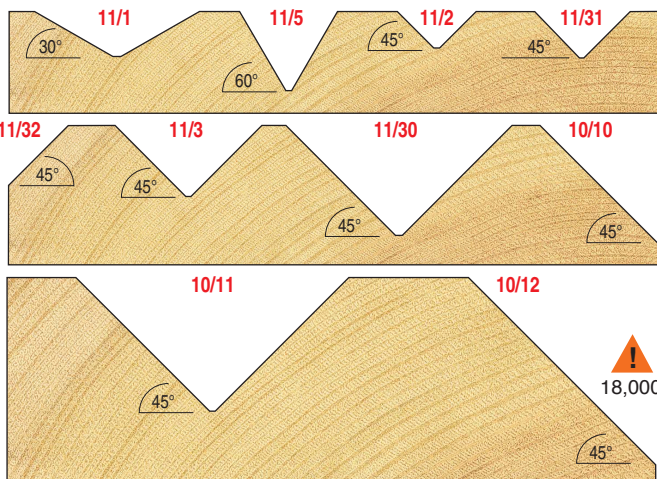
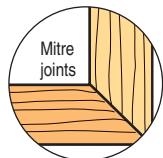

A Deg.	D mm	C mm	C2 mm	Product Ref.	Shank Diameter 1/4"	Shank Diameter 8mm	Shank Diameter 1/2"
30°	21.5	5.5	12.0	11/1	£34.39	-	£34.39
60°	12.7	10.3	11.9	11/5	£26.76	£26.76	£26.76
45°	9.5	5.0	6.5	11/2	£33.08	-	£31.48
45°	12.7	6.5	9.0	11/31	£24.22	-	£24.22
45°	16.0	8.0	11.0	11/32	£25.96	-	£25.96
45°	19.1	9.2	13.0	11/3	£28.70	£28.70	£28.70
45°	25.4	13	17.5	11/30	£54.50	-	£51.89
45°	32.0	15.0	22.0	10/10	-	-	£52.19
45°	38.0	19.0	26.5	10/11	-	-	£49.64
45°	51.0	25.0	35.0	10/12	-	-	£100.14

## SHANK MOUNTED BALL BEARING CUTTER

Decorative fluting following a template.

Follows template mounted on board surface. Template should be at least 5mm thicker than cutter cut length. Approx. 1.0mm flat will be found on nose.



Ref. 11/20

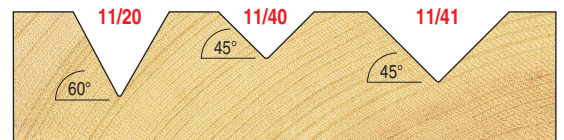
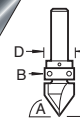

A Deg.	D mm	C mm	B mm	Product Ref.	Shank Diameter 1/4"	Shank Diameter 1/2"
60°	12.7	16.0	12.7	11/20	£36.94	-
45°	12.7	12.7	12.7	11/40	£32.46	-
45°	19.1	16.0	19.1	11/41	-	£44.57

## MORTAR GROOVE & LARGE CHAMFER

Use for producing mortar grooves and for bevelling applications.

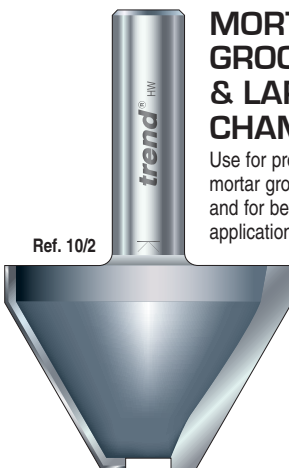

Ref. 10/2

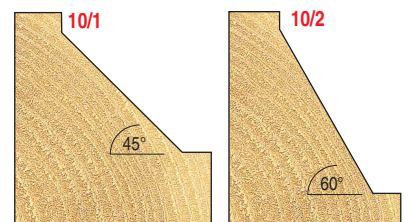
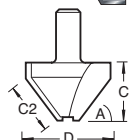

A Deg.	D mm	C mm	C2 mm	Product Ref.	Shank Dia. 1/2"
45°	41.0	22.5	23.0	10/1	£52.78
60°	38.0	27.0	25.5	10/2	£57.28

## BEARING GUIDED 45° CHAMFER

A range of guided chamfering cutters. Ref. 46/361 is supplied with a nylon sleeved bearing and can be used on solid surface material to give a 14.3mm chamfer width. A smaller bearing accessory can be fitted to increase chamfer width.

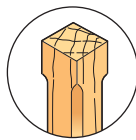

Ideal for newel posts and caps for stairs.

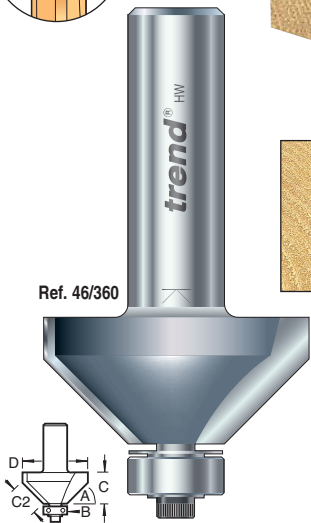
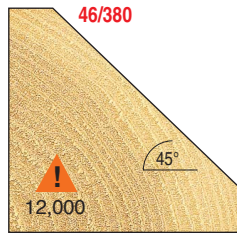
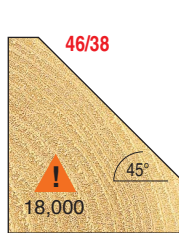
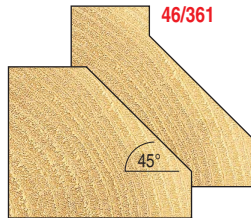
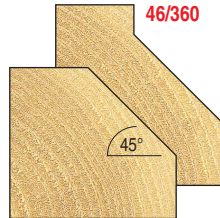
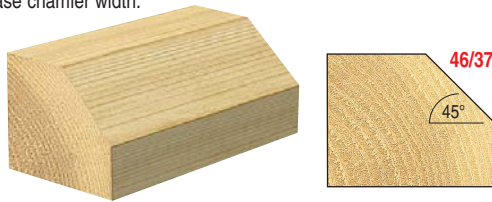

SUPPLIED WITH ONE BEARING

A Deg.	D mm	C mm	C2 mm	B mm	Product Ref.	Shank Diameter 1/4"	Shank Diameter 1/2"	ACCESSORY	Product Ref.	Price
45°	31.8	12.0	16.0	9.5	46/37	£57.87	£57.87	Bearing for Ref. 46/361 allows 15.9mm chamfer width.	B95A	£5.93
45°	35.1	12.0	16.0	12.7	46/360	£69.39	£69.39			
45°	41.3	20.0	19.0	12.7	46/361	-	£69.57			
45°	50.0	19.0	26.0	12.7	46/38	-	£75.09			
45°	76.2	25.4	35.0	25.4	46/380	-	£118.49			

## BEARING GUIDED 45° CHAMFER

For a neat chamfered edge.

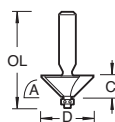

A Deg.	D mm	C mm	B mm	OL mm	Product Ref.	Shank Dia. 1/4"
45°	14.3	6.35	4.8	47.0	MB/05	£25.43

⚠ Miniature bearing has limited life.

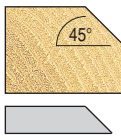

## PIN GUIDED CHAMFER/ BEVEL

Popular in the sign making trade. For the fast chamfering/bevelling edges of plastic material.

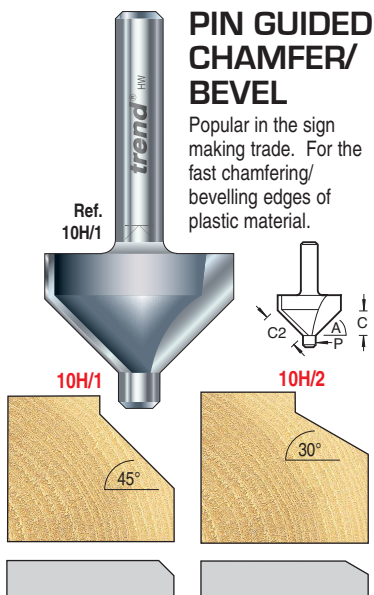

A Deg.	C mm	C2 mm	P mm	Product Ref.	Shank Dia. 1/4"
45°	10.0	14.0	5.5	10H/1	£41.41
30°	6.3	12.0	5.5	10H/2	£42.02

## BEARING GUIDED 45° 3 FLUTE CHAMFER

For use on wood and man-made board. Ideal for extra fine finish.

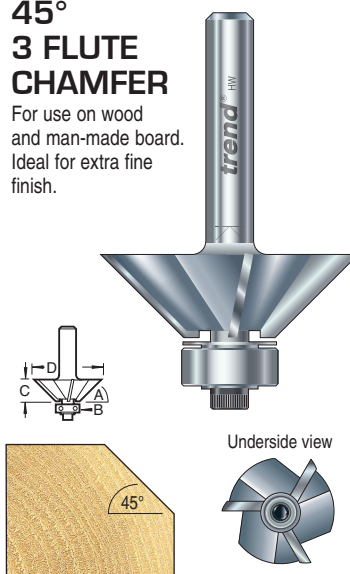

A Deg.	D mm	C mm	B mm	Product Ref.	Shank Dia. 1/4"
45°	34.0	11.0	12.7	41/5	£49.64

## BEARING GUIDED BEVEL

These guided tools are supplied with two bearings. The larger bearing removes the flat.

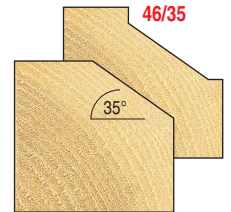
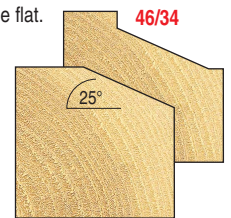
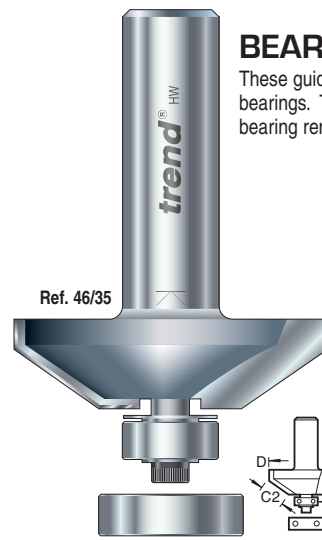

SUPPLIED WITH TWO BEARINGS

A Deg.	D mm	C mm	C1 mm	C2 mm	B mm	Product Ref.	Shank Diameter 8mm	Shank Diameter 1/2"
25°	41.0	13.0	5.0	13.0	12.7&19.0	46/34	£55.35	£55.35
35°	41.5	13.0	8.0	13.7	12.7&19.0	46/35	-	£64.90

## BEVEL CUTTER

Useful for bevelling thick timbers. Certain sizes can be used for jointing, boxes, pilasters and carcassing. Ref. 11/17 is ideal for use by wood turners with smaller routers to create staves on 25mm stock. For full bevells a template should be fitted to component.

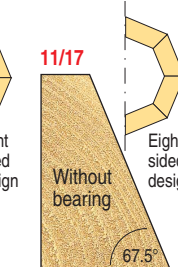
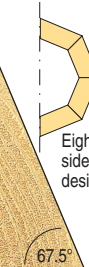
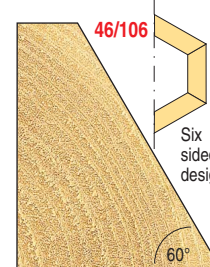
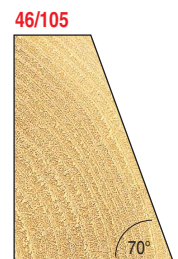
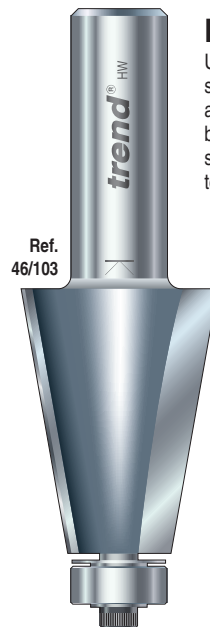

BEARING GUIDED

A Deg.	D mm	D2 mm	C mm	C2 mm	B mm	Product Ref.	Shank Dia. 1/2"
80°	26.0	12.7	35.0	36.0	12.7	46/103	£69.39
75°	30.0	12.7	35.0	36.0	12.7	46/104	£75.09
70°	35.0	12.7	35.0	38.0	12.7	46/105	£75.09
60°	53.0	12.7	35.0	40.0	12.7	46/106	£100.51
67.5°	42.0	12.7	35.0	38.5	12.7	46/107	£75.09

WITHOUT BEARING

A Deg.	D mm	C mm	Product Ref.	Shank Dia. 1/4"
67.5°	28.0	28.0	11/17	£53.40

