

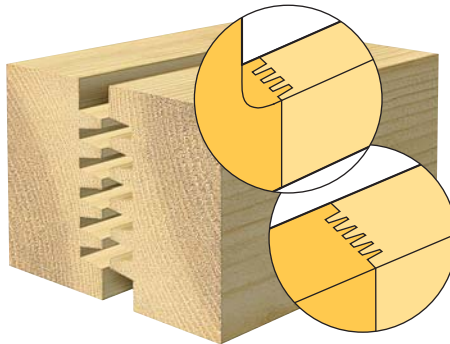

BEARING GUIDED FINGER JOINTER SET 866

Ref. 866 Finger Jointer combines an assembly of five TCT slotting cutters with an abutting-edge cutter to produce a profile that extends the glue line threefold, resulting in an extremely strong joint. It fits into any portable or stationary router with a 1/2" collet.

Performing the cut
Timber must be machined square. The cutters should be assembled to match the spindle rotation, and be stacked at 90° to one another to ease stress on the tool.



Fitted with 1 cutter
Timber thickness
Min. 11.0mm (7/16")
Max. 16.0mm (5/8")

Fitted with 5 cutters
Timber thickness
Min. 31.0mm (1-3/16")
Max. 36.0mm (1-3/8")

Timber thickness
Min. 11.0mm (7/16")
Max. 36.0mm (1-3/8")

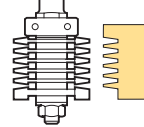
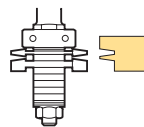

D mm	E mm	B mm	OL mm	Product Ref.	Shank Diameter 1/2"
40.0	6.0	28.0	96.0	866	£111.39

SPARE PARTS

Arbor with spacers	SP-866A	£29.31
Tapered finger cutter - 2 wing	SP-866B	£17.19 (each)
Tapered butting cutter - 2 wing	SP-866C	£19.13
Bearing 28mmØ	BB28	£13.69
Spacer 8mm bore x 3.4mm thick	SPAC/8/34	£1.69 (each)

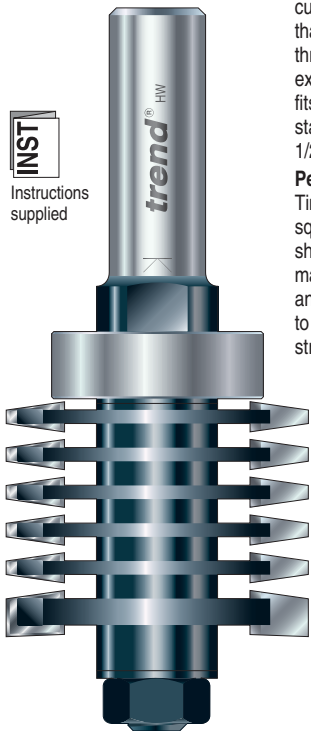

INST
Instructions supplied

BEARING GUIDED FINGER JOINTER SET 865

A bearing guided reversible finger jointer, to increase the gluing area for edge to edge joints.

Timber thickness
Min. 11.0mm
Max. 26.0mm

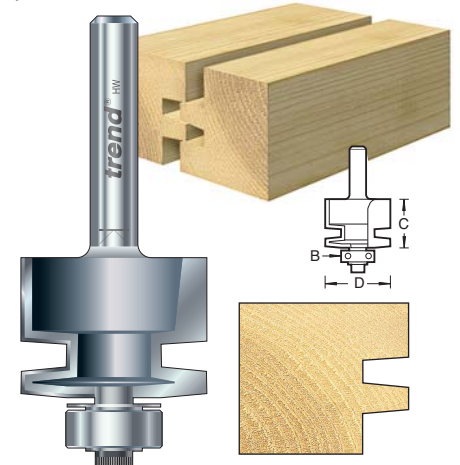

D mm	C mm	B mm	Product Ref.	Shank Dia. 1/4"
24.6	18.5	12.7	865	£60.43

OFFSET TONGUE & GROOVER

A heavy duty reversible finger jointer, to increase the gluing area for edge to edge joints.

Timber thickness
Min. 14.0mm
Max. 25.0mm

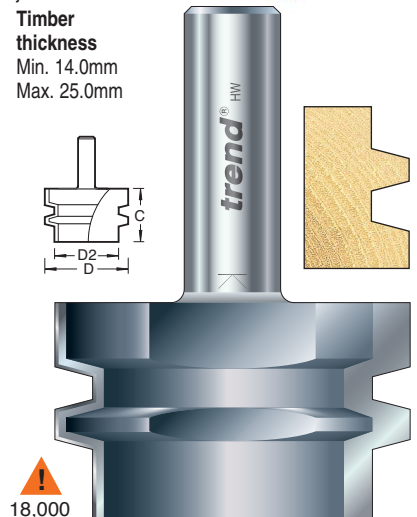

D mm	D2 mm	C mm	Product Ref.	Shank Dia. 1/2"
47.5	37.0	30.0	87/01	£93.49

BEARING GUIDED COMB JOINTER SET 876

This Comb Jointing Set can be fitted to all heavy duty routers mounted in a fixed head position. It comprises a set of five 4mm kerf, TCT groovers, mounted on an arbor and three ball bearings. These offer alternative cutting depths and provide a self-guiding facility.

The Comb Jointer is ideally suited for producing small boxes, instrument cases etc.

Please note, timber ends must be cut square.

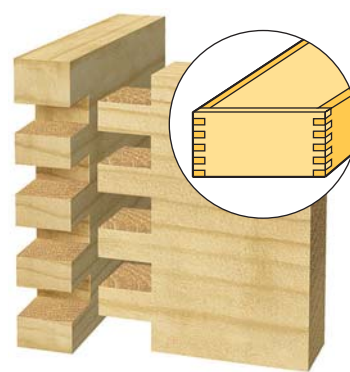

Timber width
Max. 40.0mm

D mm	C mm	B mm	OL mm	Product Ref.	Shank Diameter 1/2"
47.6	4.0	28.0	96.0	876	£122.65

SPARE PARTS

Arbor with spacers	SP-876A	£29.91
Slotter - 3 wing	SP-876B	£17.81 (each)

Timber Thickness

Bearing 34mmØ up to 6.5mm	BB34	£13.69
Bearing 29mmØ 6.6mm to 9.0mm	BB29	£13.69
Bearing 28mmØ 9.1mm to 9.5mm	BB28	£13.69
Spacer 8mm bore x 5.3mm thick	SPAC/8/53	£1.69 (each)

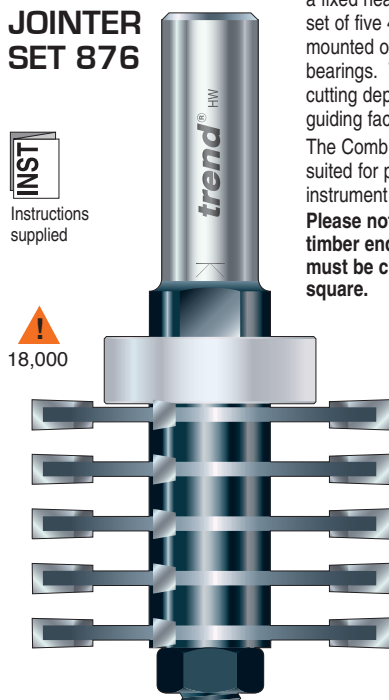

INST
Instructions supplied

⚠
18,000

⚠
18,000

MITRE CORNER

These cutters produce a lapped mitre joint.

Timber thickness

Min. 15.0mm
Max. 18.0mm

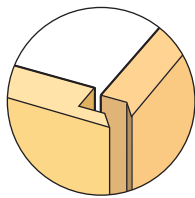

Box construction

Ref. 10/20

Ref. 10/21

18,000

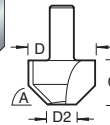
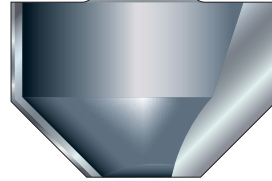
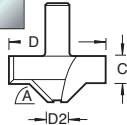
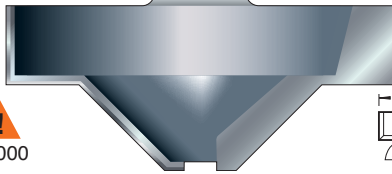

A Deg.	D mm	D2 mm	C mm	Product Ref.	Shank Dia. 1/2"
45°	51.3	10.0	23.0	10/20	£111.39
45°	35.0	15.0	25.0	10/21	£96.63



Instructions supplied

MITRE LOCK JOINTER

Machining of this joint is carried out by routing one piece with the inside face on the table. The matching corner inside face is machined upright against the fence. Make sure that the cutter is centred on the workpiece. The cutter can also be used for a glue joint to join lengths together. Ideal for speaker cabinets and drawer construction.

Please note. These tools cannot be re-sharpened. Inverted use only.

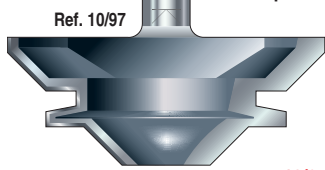
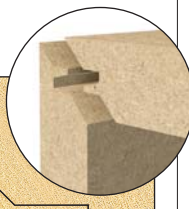

Ref. 10/97

Timber thickness
Min. 8.0mm
Max. 12.0mm



A Deg.	D mm	C mm	C2 mm	Product Ref.	Shank Diameter 1/4" 1/2"
45°	42.0	12.7	4.0	10/97	£100.14
45°	68.0	30.0	12.5	10/99	£111.39

24,000



16,000

Timber thickness
Min. 15.0mm
Max. 25.0mm

BUTTERFLY SPLINE CUTTER

A decorative joint for butterfly keys and splines. Use in conjunction with 104° (14°) dovetail cutters Ref. L120, 31/33, 31/12, 31/23, 31/25 & 31/50. For use in router tables.

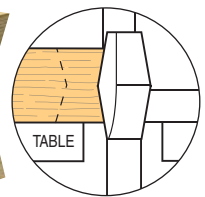

See Arched Mirror project at www.trend-uk.com



Instructions supplied

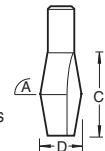

A Deg.	D mm	C mm	Product Ref.	Shank Dia. 1/2"
104°	28.5	44.0	10/40	£62.98

DRAWER LOCK JOINTER

To increase gluing area, producing a strong joint in drawer production.

Timber thickness
Min. 15.0mm
Max. 25.0mm

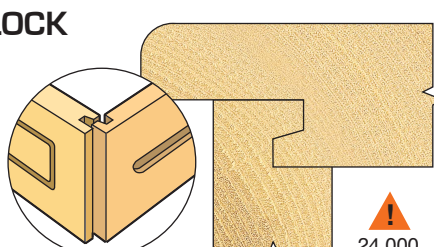

24,000

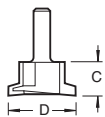

D mm	C mm	Product Ref.	Shank Diameter 1/2"
25.4	12.7	10/30	£37.54

BEARING GUIDED KNUCKLE JOINT CUTTER

Cutters to create knuckle joints for gate leg tables. The cutter should be used in a router table. Hand tools will be required to finish the joint.

Timber thickness:
Ref. 9/41 For 14.0mm to 15.0mm.
Ref. 9/42 For 19.0mm.

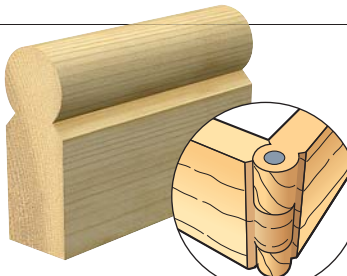

Instructions supplied

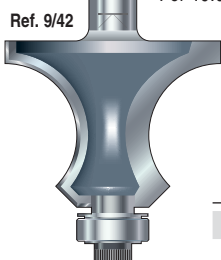

Ref. 9/42

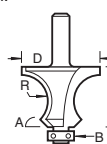

A Deg.	R mm	D mm	C mm	B mm	Product Ref.	Shank Dia. 1/4"
45°	7.14	23.8	17.0	9.5	9/41	£42.02
45°	9.5	28.5	22.0	9.5	9/42	£45.76

24,000



9/41



9/42

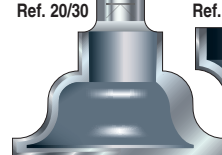

Ref. 20/30



Ref. 20/3

CLASSIC PANEL

These cutters simplify the construction of framing. The scribe matches the profile to form a shoulder scribe. Tenon and groove/rebate must be cut separately.

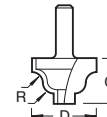
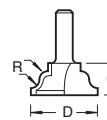
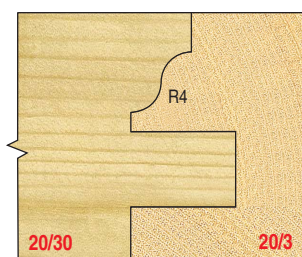

R mm	D mm	C mm	Product Ref.	Shank Dia. 1/4"
4.0	28.5	16.5	20/30	£79.55
4.0	24.0	17.0	20/3	£66.12