

LAMINATE TRIMMERS

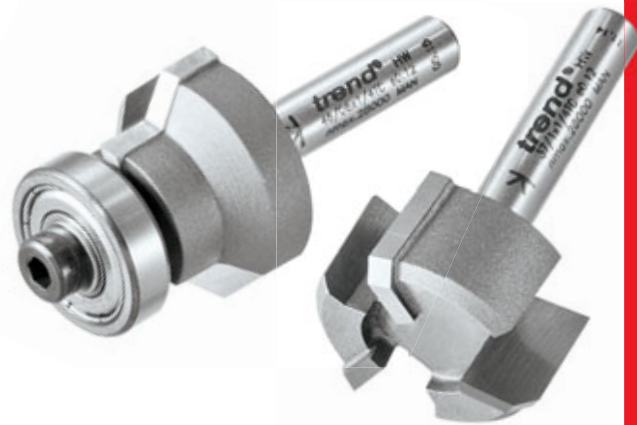
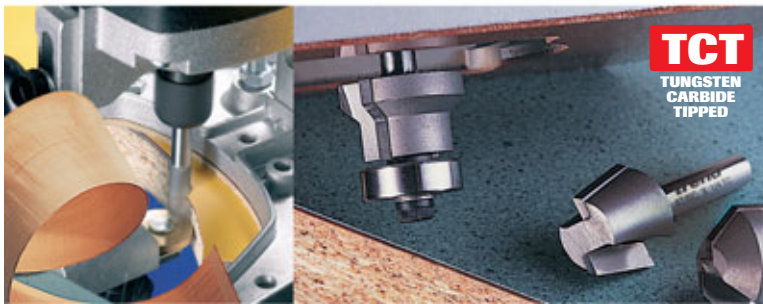

PROFESSIONAL ROUTER CUTTERS

STC GUIDED ECONOMY TRIMMER

- Solid Tungsten Carbide economy trimmer.
- Ref. S48/39 & S48/40 for self-guiding 90° trimming only.
- Ref. S48/41 self-guiding at 83°.
- Ref. S48/42 is for trimming on a rebate. The guide length is 3mm.
- Ref. S48/39 is a shorter version of Ref. S48/40.

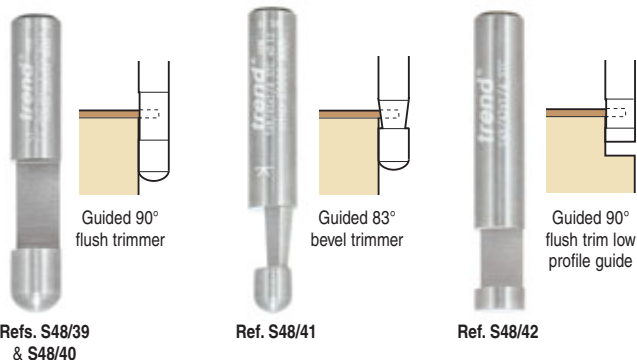

Refs. S48/39 & S48/40

Ref. S48/41

Ref. S48/42

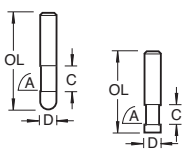

A Deg.	D mm	C mm	OL mm	Product Ref.	Shank Dia. 1/4"
90°	6.3	10.0	38.0	S48/39	£26.47
90°	6.3	10.0	52.0	S48/40	£30.56
83°	6.3	6.0	38.0	S48/41	£26.47
90°	6.3	6.0	35.0	S48/42	£26.47

STC ECONOMY TRIMMER

- Solid Tungsten Carbide economy trimmer.
- For use on short runs.
- Ref. S47/72 trims 90° or 45°.
- Ref. S47/70 trims 90° or 60°.
- Ref. S47/71 trims 90° or 83°.
- Will trim and bevel by changing cutter height.
- Requires a side-fence or a copy follower guide on the router.

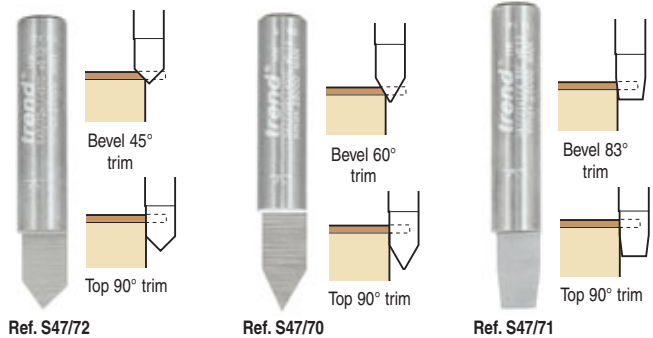

Ref. S47/72

Ref. S47/70

Ref. S47/71

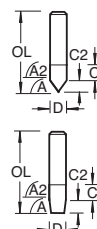

A Deg.	A2 Deg.	D mm	C mm	C2 mm	OL mm	Product Ref.	Shank Dia. 1/4"
45°	90°	6.3	6.3	3.2	38.0	S47/72	£26.47
60°	90°	6.3	6.0	6.0	32.0	S47/70	£29.24
83°	90°	6.3	5.0	4.5	38.0	S47/71	£26.47

COMBI TRIMMER

- For trimming top & lip.
- Economical cutter, performs 3 functions:
 1. To top trim the overlay at 90°.
 2. To trim the overlay at 60°.
 3. The base of the cutter can trim the vertical lipping at 90°.
- Requires side-fence or roller bearing.

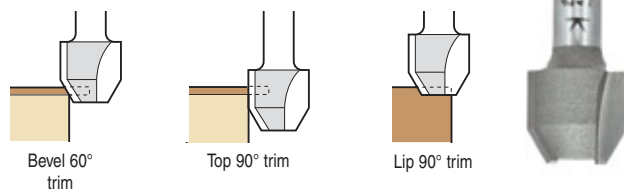

A Deg.	A2 Deg.	D mm	C mm	Product Ref.	Shank Dia. 1/4"
60°	90°	12.7	12.7	47/7	£27.79

