

REBATE CUTTERS



BEARING GUIDED REBATE SET

- Popular rebate sets which include different size bearings for a choice of rebates.
 - Easy to set-up and accurate depth of cut.
 - Ideal for rebating straight and shaped workpieces.
 - **Ref. 46/39L** has a 60mm shank length to give access to deep rebates.
 - **Ref. 46/44** is ideal for delicate applications such as musical instrument production, when a small rebate is required for insertion of purfling.
- ⚠ When using bearing **Ref. B95A**, make two passes if a full depth of cut is required by using a larger bearing first.



Applications for Bearing Guided Cutters

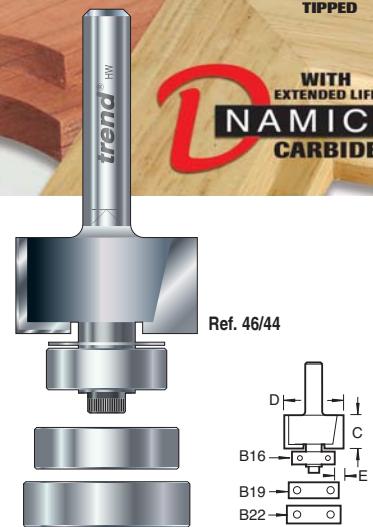
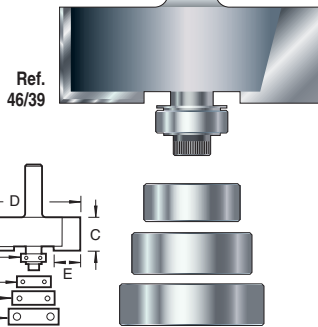

D mm	C mm	Product Ref.	Shank Diameter		
			1/4"	8mm	1/2"
35.0	12.7	46/39	£65.52	£65.52	£70.60
35.0	12.7	46/39L	-	-	£79.55

D mm	C mm	Product Ref.	Shank Diameter	
			1/4"	8mm
24.0	12.7	46/44	£60.43	£60.43

SUPPLIED WITH FOUR BEARINGS BELOW

Rebate E mm	Bearing Dia. mm	Product Ref.	Price
7.9	19.0	B19A	£7.64
9.5	16.0	B16A	£6.06
11.1	12.7	B127A	£4.74
12.7	9.5	B95A	£5.93

SUPPLIED WITH THREE BEARINGS BELOW

Rebate E mm	Bearing Dia. mm	Product Ref.	Price
1.0	22.0	B22	£10.13
2.5	19.0	B19	£4.74
4.0	16.0	B16	£4.24

ALTERNATIVE BEARINGS

Rebate E mm	Bearing Dia. mm	Product Ref.	Price
2.0	20.0	B20	£10.13
3.0	18.0	B18	£11.15
3.5	17.0	B17	£10.90
4.5	15.0	B15	£10.90
5.0	14.0	B14	£10.90
5.6	12.7	B127	£7.15



Instructions supplied

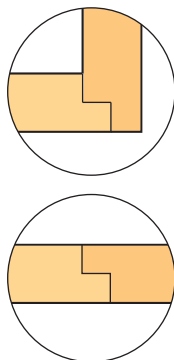

BEARING GUIDED LARGE REBATER

- Bearing guided for straight or curved work for portable and stationary routers.
- Supplied as standard with **Ref. BR/191** fitted.
- A variety of alloy bearing rings are available as accessories to give various rebate sizes. Rings are secured between the two bearings.

D mm	C mm	E mm	Product Ref.	Shank Dia. 1/2"
50.8	22.5	19.1 & 15.9	46/390	£82.10

Alternative size rebates using alloy bearing rings below

Rebate E mm	Ring Dia. mm	Product Ref.	Price
3.2	44.4	BR/444	£7.64
4.75	41.3	BR/413	£7.64
6.35	38.1	BR/381	£7.64
9.5	31.7	BR/317	£7.64
12.7	25.4	BR/254	£5.46
14.3	22.2	BR/222	£5.46
15.1	20.6	BR/206	£5.46
15.9	19.1	BR/191	£5.46
17.45	15.9	BR/159	£5.46
18.25	14.3	BR/143	£5.46

SPARE PART	Product Ref.	Price
Step washer	BWASH/14A	£1.33

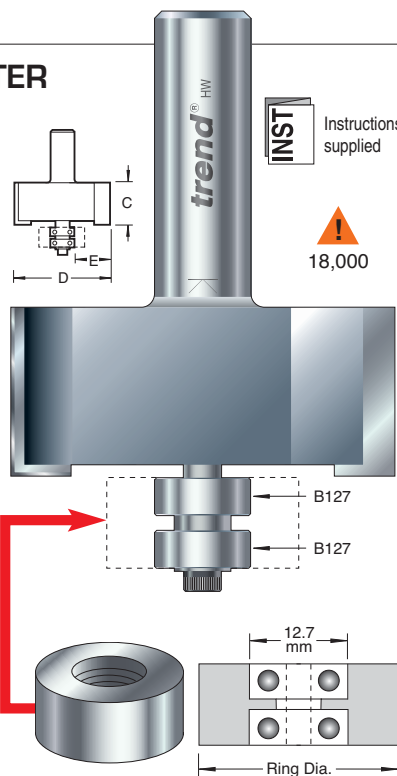

MINIATURE BEARING GUIDED REBATER

- Follows the work edge to give a preset width of rebate.
 - Small bearing allows access into tight corners.
- ⚠ A miniature bearing is fitted which has a limited life of approx. 100 linear metres, after which it must be replaced.

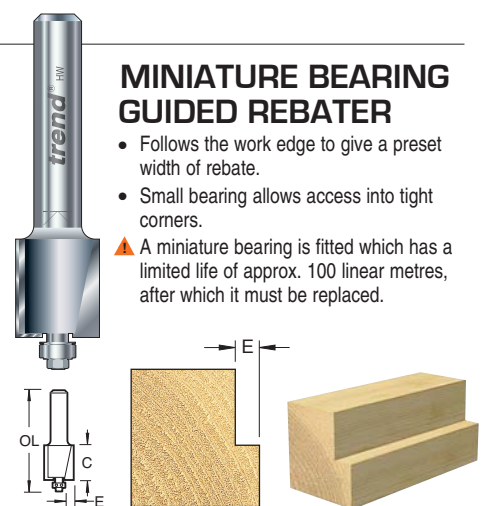

D mm	C mm	B mm	E mm	OL mm	Product Ref.	Shank Dia. 1/4"
11.1	13.0	4.8	3.1	51.0	MB/02	£23.60

MINIATURE BEARING CUTTERS

For full range, see page 60 for full details.



RECESSERS



SHANK MOUNTED BEARING GUIDED HOUSING CUTTER

- Creates grooves and trenches in boards.
- Bearing follows template.
- For rebating and housings.



Ref. 21/1

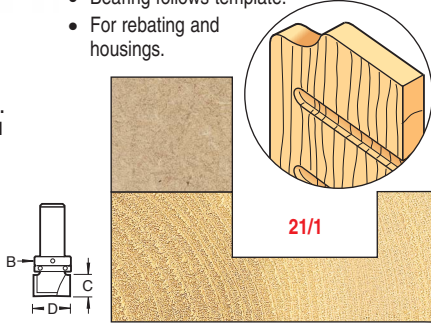

D mm	C mm	B mm	Product Ref.	Shank Diameter 1/4"	Shank Diameter 1/2"
19.1	11.1	19.1	21/1	£42.62	£42.62
25.4	11.1	25.4	21/2	-	£44.57
38.1	16.0	38.1	21/3	-	£62.37

TAPERED STRAIGHT

- Two flute straight cutters with 3° taper.
- Designed for constructing wooden vacuum forming moulds.
- Tapered sides will allow the mould to release easily.
- Ref. 10/26 can be used for producing a leading edge on a door.



Ref. 10/25

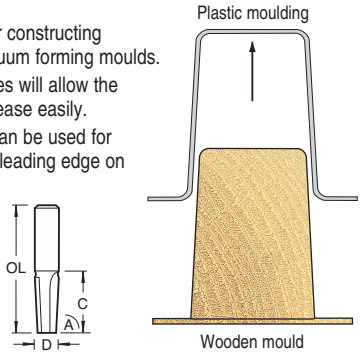

A Deg.	D mm	C mm	OL mm	Product Ref.	Shank Dia. 1/2"
87°	12.7	32.0	80.0	10/25	£43.25
87°	16.0	63.0	110.0	10/26	£75.09

SHANK MOUNTED BEARING GUIDED ESPAGNOLETTE LOCK RECESS CUTTER

- For lock mechanism in French doors and windows.
- Stepped groove 16mm/12.3mm x 12mm/9.5mm deep.

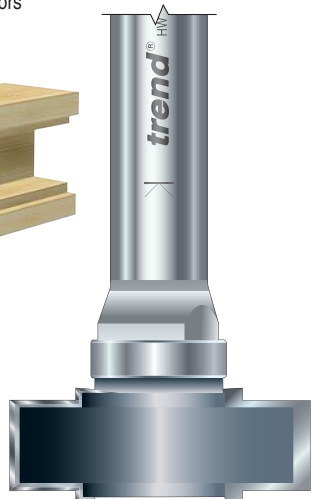
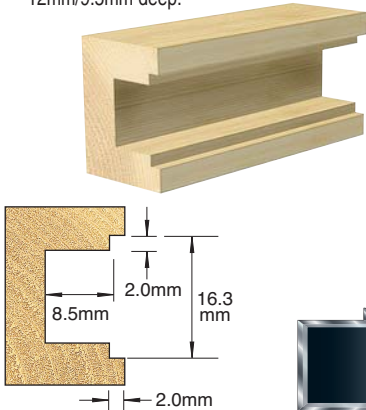

C mm	C2 mm	D mm	B mm	Product Ref.	Shank Dia. 1/2"
16.3	12.3	40.0	19.0	34/50	£93.98

BEARING GUIDED INLAY SET

- To produce grooves for the insertion of coloured or natural wood inlay.
- Supplied with three bearings to allow different depths of cut.
- Alternative bearings available.

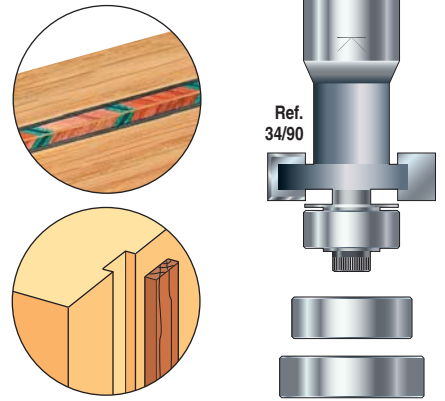

Ref. 34/90

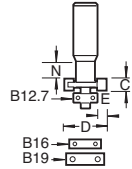

C mm	D mm	N mm	OL mm	Product Ref.	Shank Dia. 1/2"
6.3	22.2	19.0	77.0	34/90	£50.86

SUPPLIED WITH THREE BEARINGS

Depth E mm	Bearing Dia. mm	Product Ref.	Price
1.6	19.0	B19	£4.74
3.2	16.0	B16	£4.24
4.75	12.7	B127	£7.15

ALTERNATIVE BEARINGS

Depth E mm	Bearing Dia. mm	Product Ref.	Price
0.6	21.0	B21	£10.13
1.1	20.0	B20	£10.13
2.1	18.0	B18	£11.15
2.6	17.0	B17	£10.90
3.6	15.0	B15	£10.90
4.1	14.0	B14	£10.90

STRIP RECESSER

- Four sizes of recessing cutters for producing double rebates.
- For producing recesses with a lower rebate.
- Designed to accept library/bookcase shelving strip. Ref. 36/19 is specifically designed for Tonk Strip.

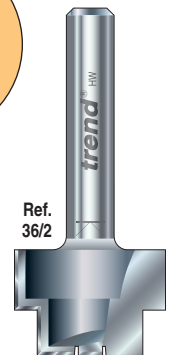
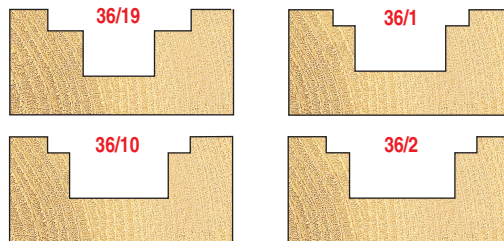

Ref. 36/2

D mm	D2 mm	C mm	C2 mm	Product Ref.	Shank Diameter 1/4"	Shank Diameter 1/2"
9.5	19.0	13.0	6.0	36/19	£50.86	£50.86
12.0	18.0	10.0	6.0	36/1	£54.13	-
13.0	19.0	10.0	6.0	36/10	£55.94	-
14.0	20.0	8.0	6.0	36/2	£54.74	£54.74

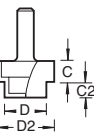

PIN GUIDED COUNTERBORE RECESSER

- Creates counterbore for a bolt slot in jigs.
- Use on MDF, plywood and acrylic.

A 5mm to 6.35mm wide slot is first routed. Use the pin to guide the recesser to create a counterbored slot for M5 and M6 pan head machine screw.

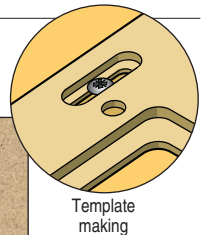
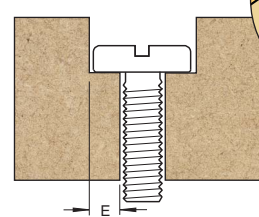

Template making

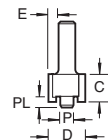

E mm	D mm	C mm	P mm	PL mm	Product Ref.	Shank Dia. 1/4"
4.0	13.0	12.0	4.8	4.0	8D/4	£47.48 +

