

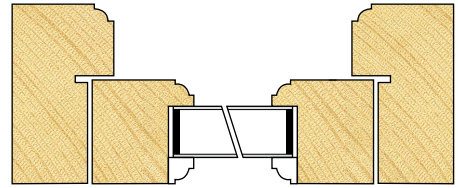

**Top View AA**

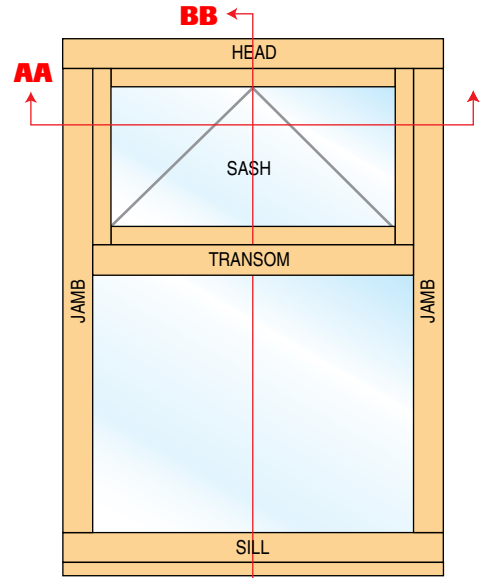

**Side View BB**

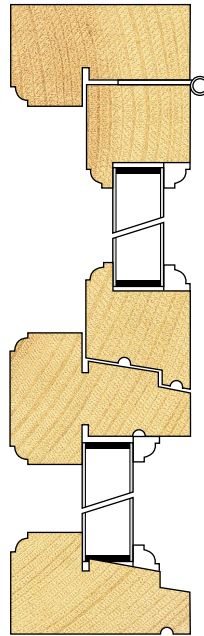

**Dimensions**

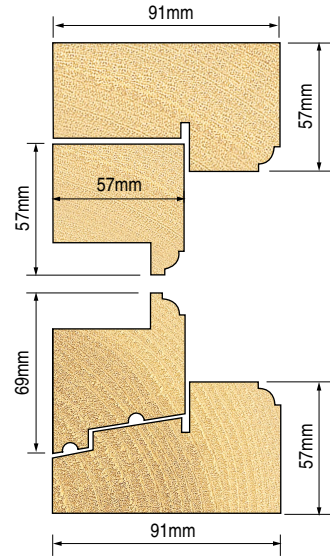

**Timber Traditional Flush style windows with the following features:**

- Outer frame section 91mm x 57mm. Sash section 57mm x 57mm.
- An optional 69mm x 57mm bottom rail can also be produced.
- Standard ovolo profile on outer frame and sash.
- All outer frame and sash joints are combed.
- Will also produce single tenon for mullion and transom joints (mortise hole required).
- Uses standard butt hinges, fasteners and stays.
- 4mm groove width in outer frame to accept standard weather seals. Alternative 3mm groove width can be produced - see page 55.
- Produces 15mm rebate depths in outer frame.
- Produces 15mm x 42mm rebates in the sash.
- Routing jig also available for producing the slot in the sash for the trickle vent.

Complete set of **33** tools with 30mm bore (or 1-1/4") including spacers and setting gauge.

Product Ref	Bore	Price
IT/MWS/SET081	30mm	£4,528.30
IT/MWS/SET087	1-1/4"	£4,528.30

This system is supplied with a wallchart and individual specification sheets per step. The wallchart can be mounted next to the spindle moulder for quick selection of tools.



Description	Product Ref
Wallchart	WALL/MWS/TFO
Specification Manual	MANU/MWS/TFO

**Warning this style can only be used on a flush sliding table.**

**Beading** The profile tools in the system can be used for creating the beads, but require changes to the spindle machine settings.

**Shared Common Tools** When purchasing in conjunction with other styles please see pages 44 & 45.



## Step 1 Outer Frame Tenon for Jamb to Head

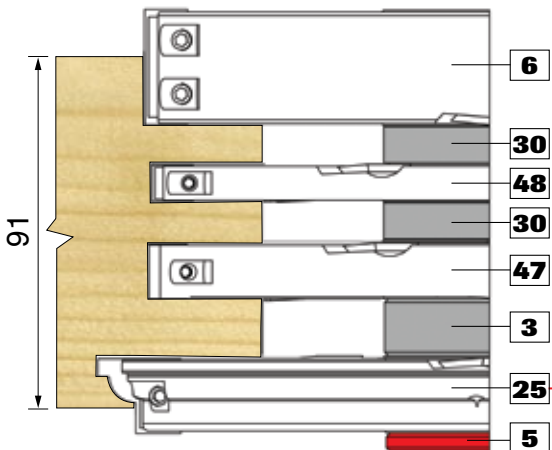

Tools/Spacers			Replacement Knives			
Item No	Product Ref. 30mm (1-1/4")	Description	Size	Product Ref.	Size	Product Ref.
6	IT/7105461(7)	Rebate Head	30x12x1.5	IT/3101230/10	14x14x2.0	IT/3008503/10
30	IT/1920531(7)	Spacer	N/A			
48	IT/71054481(7)	Tenon Head	10x12x1.5	IT/3007507/10	14x14x2.0	IT/3008503/10
47	IT/71054471(7)	Tenon Head	14.6x12x1.5	IT/3108702/10	14x14x2.0	IT/3008503/10
3	IT/1920541(7)	Spacer	N/A			
25	IT/71054251(7)	Ovolo Head	20x23x2.0	IT/3108567	14x14x2.0	IT/3008503/10
5	IT/1920061(7)	Spacer	N/A			

Replacement knives with a /10 are sold in packs of 10.

Alternative profile styles, see pages 41 - 43.

**Warning** **Recommended Speed 3,500 - 4,500 RPM**

**Step 2 to 14 >**

## Step 2 Outer Frame Tenon for Jamb to Sill

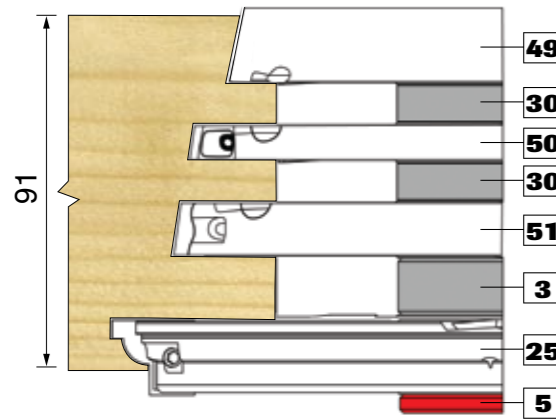

Tools/Spacers			Replacement Knives			
Item No	Product Ref. 30mm (1-1/4")	Description	Size	Product Ref.	Size	Product Ref.
49	IT/71054491(7)	Tenon Disc	19x20x2.0	IT/3108499	14x14x2.0	IT/3008503/10
30	IT/1920531(7)	Spacer	N/A			
50	IT/71054501(7)	Tenon Disc	15x10x2.0	IT/3108520	14x14x2.0	IT/3008503/10
51	IT/71054511(7)	Tenon Disc	18x14.5x2.0	IT/3108521	14x14x2.0	IT/3008503/10
3	IT/1920541(7)	Spacer	N/A			
25	IT/71054251(7)	Ovolo Head	20x23x2.0	IT/3108567	14x14x2.0	IT/3008503/10
5	IT/1920061(7)	Spacer	N/A			

Alternative profile styles, see pages 41 - 43.

**Recommended Speed**  
3,500 - 4,500 RPM

## Step 6 Tenon for Sash Rails

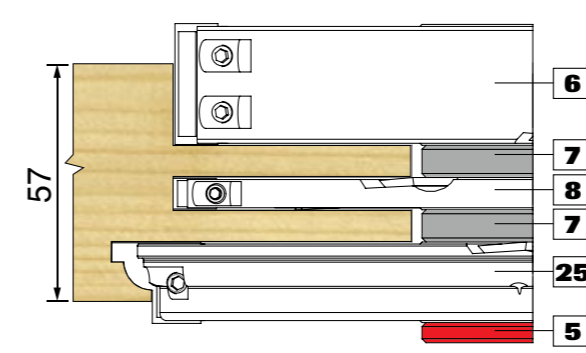

Tools/Spacers			Replacement Knives			
Item No	Product Ref. 30mm (1-1/4")	Description	Size	Product Ref.	Size	Product Ref.
6	IT/7105461(7)	Rebate Head	30x12x1.5	IT/3101230/10	14x14x2.0	IT/3008503/10
7	IT/1927801(7)	Spacer	N/A			
8	IT/7105481(7)	Tenon Head	7.5x12x1.5	IT/3107512/10	14x14x2.0	IT/3008503/10
25	IT/71054251(7)	Ovolo Head	20x23x2.0	IT/3108567	14x14x2.0	IT/3008503/10
5	IT/1920061(7)	Spacer	N/A			

Alternative profile styles, see pages 41 - 43.

**Recommended Speed**  
3,500 - 4,500 RPM

## Step 3 Outer Frame Slots for Head and Sill

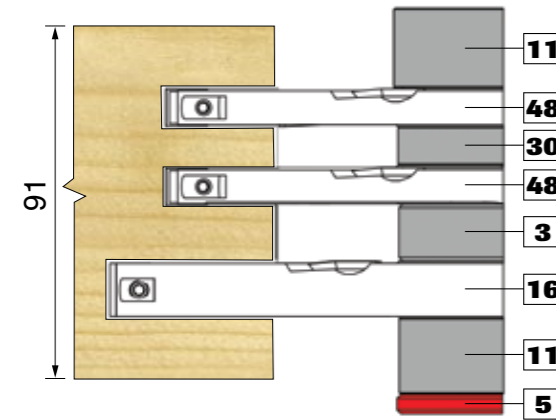

Tools/Spacers			Replacement Knives			
Item No	Product Ref. 30mm (1-1/4")	Description	Size	Product Ref.	Size	Product Ref.
11	IT/1920551(7)	Spacer	N/A			
48	IT/71054481(7)	Tenon Head	9.6x12x1.5	IT/3007507/10	14x14x2.0	IT/3008503/10
30	IT/1920531(7)	Spacer	N/A			
3	IT/1920541(7)	Spacer	N/A			
16	IT/71054161(7)	Tenon Head	14.6x12x1.5	IT/3108702/10	14x14x2.0	IT/3008503/10
5	IT/1920061(7)	Spacer	N/A			

**Recommended Speed**  
3,500 - 4,500 RPM

## Step 7 Slots for Sash Stile to Top Rail

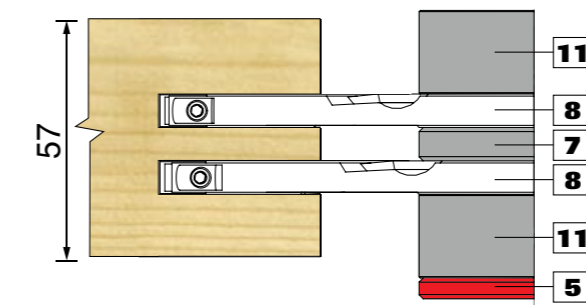

Tools/Spacers			Replacement Knives			
Item No	Product Ref. 30mm (1-1/4")	Description	Size	Product Ref.	Size	Product Ref.
11	IT/1920551(7)	Spacer	N/A			
8	IT/7105481(7)	Tenon Head	7.5x12x1.5	IT/3107512/10	14x14x2.0	IT/3008503/10
7	IT/1927801(7)	Spacer	N/A			
5	IT/1920061(7)	Spacer	N/A			

**Recommended Speed**  
3,500 - 4,500 RPM

## Step 4 Tenon for Transom and Mullion to Head & Jambs

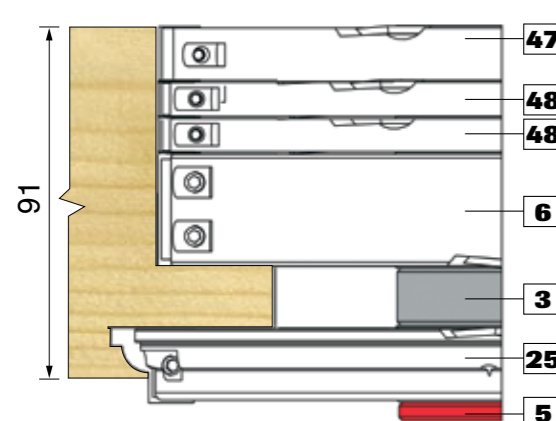

Tools/Spacers			Replacement Knives			
Item No	Product Ref. 30mm (1-1/4")	Description	Size	Product Ref.	Size	Product Ref.
47	IT/71054471(7)	Tenon Head	14.6x12x1.5	IT/3108702/10	14x14x2.0	IT/3008503/10
48	IT/71054481(7)	Tenon Head	10x12x1.5	IT/3007507/10	14x14x2.0	IT/3008503/10
6	IT/7105461(7)	Rebate Head	30x12x1.5	IT/3101230/10	14x14x2.0	IT/3008503/10
3	IT/1920541(7)	Spacer	N/A			
25	IT/71054251(7)	Ovolo Head	20x23x2.0	IT/3108567	14x14x2.0	IT/3008503/10
5	IT/1920061(7)	Spacer	N/A			

Alternative profile styles, see pages 41 - 43.

**Recommended Speed**  
3,500 - 4,500 RPM

## Step 8 Slots for Sash Stile to Bottom Rail

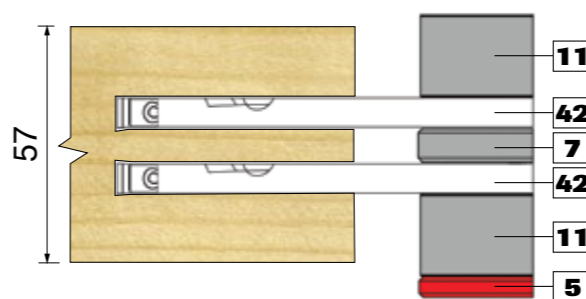

Tools/Spacers			Replacement Knives			
Item No	Product Ref. 30mm (1-1/4")	Description	Size	Product Ref.	Size	Product Ref.
11	IT/1920551(7)	Spacer	N/A			
42	IT/71054421(7)	Tenon Head	7.5x12x1.5	IT/3107512/10	14x14x2.0	IT/3008503/10
7	IT/1927801(7)	Spacer	N/A			
5	IT/1920061(7)	Spacer	N/A			

**Recommended Speed**  
3,500 - 4,500 RPM

## Step 5 Tenon for Mullion to Sill only

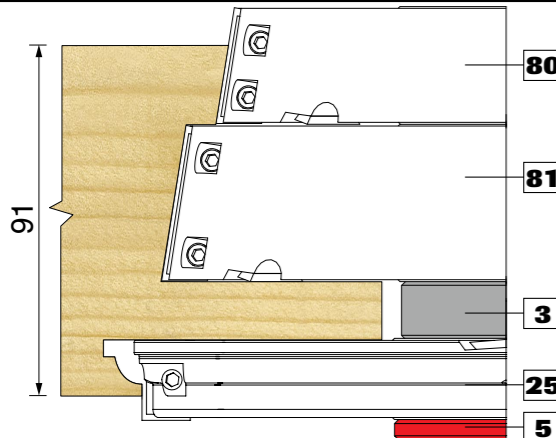

Tools/Spacers			Replacement Knives			
Item No	Product Ref. 30mm (1-1/4")	Description	Size	Product Ref.	Size	Product Ref.
80	IT/71054801(7)	Tenon Head	30x20x2.0	IT/3208050	-	-
81	IT/71054811(7)	Tenon Head	42x19x2.0	IT/3208072	14x14x2.0	IT/3008503/10
3	IT/1920541(7)	Spacer	N/A			
25	IT/71054251(7)	Ovolo Head	20x23x2.0	IT/3108567	14x14x2.0	IT/3008503/10
5	IT/1920061(7)	Spacer	N/A			

Replacement knives with a /10 are sold in packs of 10.

Alternative profile styles, see pages 41 - 43.

**Recommended Speed**  
3,500 - 4,500 RPM

## Step 9 Outer Frame for Head and Jambs only

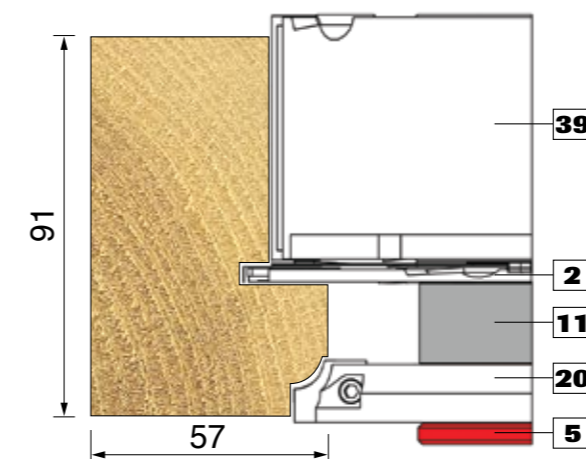

Tools/Spacers			Replacement Knives			
Item No	Product Ref. 30mm (1-1/4")	Description	Size	Product Ref.	Size	Product Ref.
39	IT/71054391(7)	Rebate Head	60x12x1.5	IT/3000531/10	14x14x2.0	IT/3008503/10
2	IT/7105421(7)	Groover	18x18x2.0	IT/3008501/10	14x14x2.0	IT/3008503/10
11	IT/1920551(7)	Spacer	N/A			
20	IT/71054201(7)	Ovolo Head	15x20x2.0	IT/3108627	-	-
5	IT/1920061(7)	Spacer	N/A			

Replacement knives with a /10 are sold in packs of 10.

Alternative profile styles, see pages 41 - 43.

**Recommended Speed**  
5,500 - 6,500 RPM

## Step 10 Mullion Profiling only

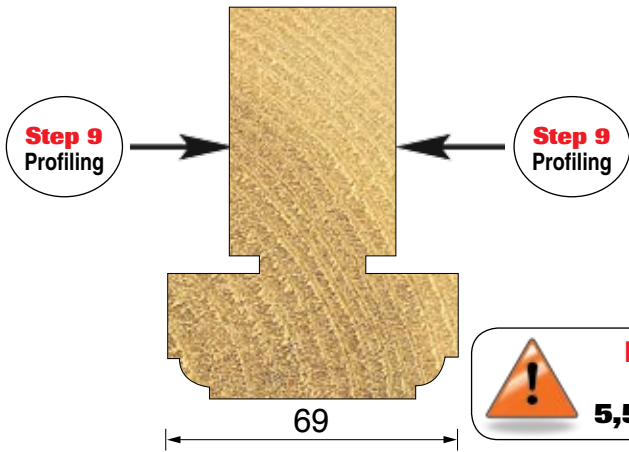

## Step 11 Transom Profiling only

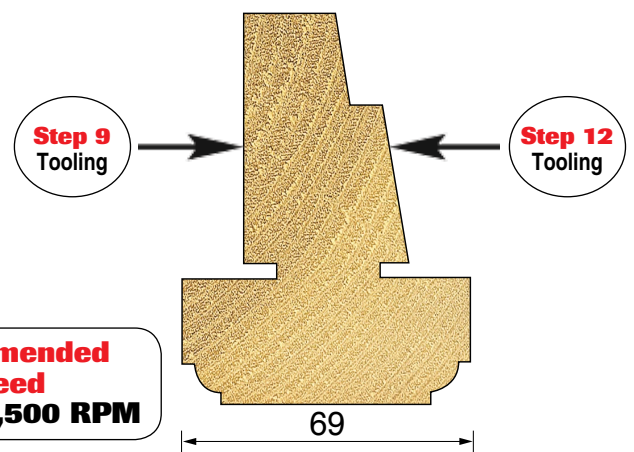

**Recommended Speed**  
5,500 - 6,500 RPM

## Step 12 Outer Frame for Sill only

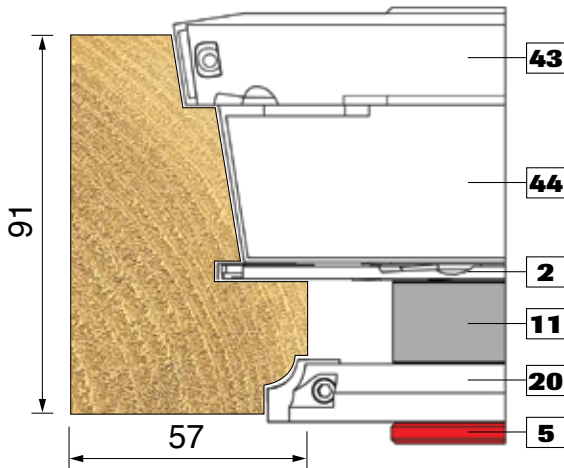

Tools/Spacers			Replacement Knives			
Item No	Product Ref. 30mm (1-1/4")	Description	Size	Product Ref.	Size	Product Ref.
43	IT/71054431(7)	Sill Head	20x12x1.5	IT/3101220/10	14x14x2.0	IT/3008503/10
44	IT/71054441(7)	Sill Head	17x38x2.0	IT/3108498	-	-
2	IT/7105421(7)	Groover	18x18x2.0	IT/3008501/10	14x14x2.0	IT/3008503/10
11	IT/1920551(7)	Spacer	N/A			
20	IT/71054201(7)	Ovolo Head	15x20x2.0	IT/3108627	-	-
5	IT/1920061(7)	Spacer	N/A			

**Recommended Speed**  
5,500 - 6,500 RPM

Alternative profile styles, see pages 41 - 43.

## Step 13 Inner Sash Profile

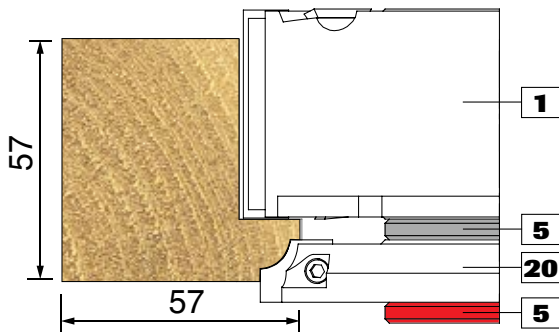

Tools/Spacers			Replacement Knives			
Item No	Product Ref. 30mm (1-1/4")	Description	Size	Product Ref.	Size	Product Ref.
1	IT/7105411(7)	Rebate Head	50x12x1.5	IT/3101250/10	14x14x2.0	IT/3008503/10
5	IT/1920061(7)	Spacer	N/A			
20	IT/71054201(7)	Ovolo Head	15x20x2.0	IT/3108627	-	-

**Recommended Speed**  
5,500 - 6,500 RPM

Alternative profile styles, see pages 41 - 43.

## Step 14 Outer Sash Profile for Bottom Rail only

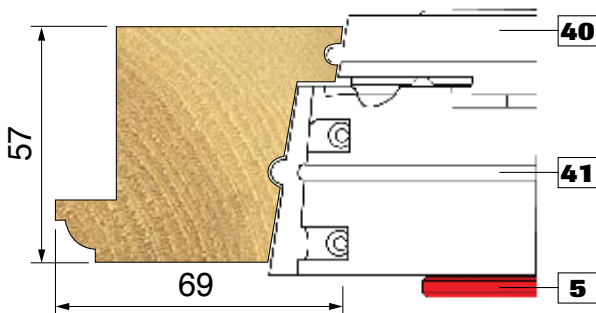

Tools/Spacers			Replacement Knives			
Item No	Product Ref. 30mm (1-1/4")	Description	Size	Product Ref.	Size	Product Ref.
40	IT/71054401	Splay Head	19.5x20x2.0	IT/3108496	-	-
41	IT/71054411	Splay Head	23x45x2.0	IT/3108497	14x14x2.0	IT/3008503/10
5	IT/1920061(7)	Spacer	N/A			

**Recommended Speed**  
5,500 - 6,500 RPM

Replacement knives with a /10 are sold in packs of 10.

