

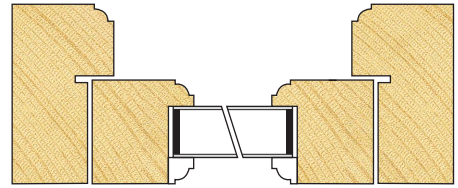

Top View AA

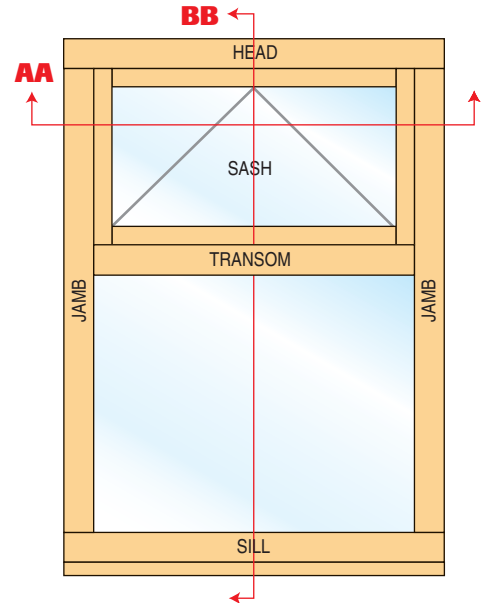

Side View BB

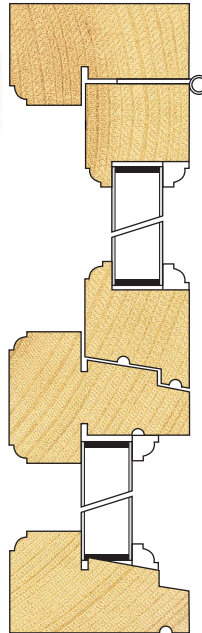

Dimensions

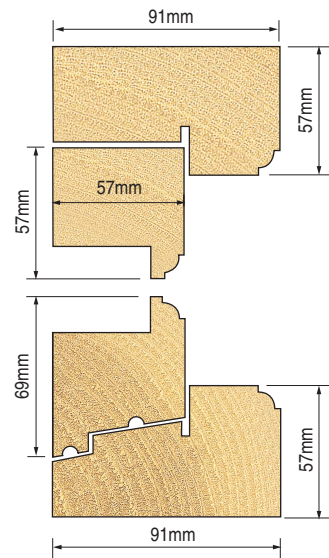

Timber Traditional Flush style windows with the following features:

- Outer frame section 91mm x 57mm. Sash section 57mm x 57mm.
- An optional 69mm x 57mm bottom rail can also be produced.
- Standard ovolo profile on outer frame and sash.
- All outer frame and sash joints are combed.
- Will also produce single tenon for mullion and transom joints (mortise hole required).
- Uses standard butt hinges, fasteners and stays.
- 4mm groove width in outer frame to accept standard weather seals. Alternative 3mm groove width can be produced - see page 55.
- Produces 15mm rebate depths in outer frame.
- Produces 15mm x 42mm rebates in the sash.
- Routing jig also available for producing the slot in the sash for the trickle vent.

Complete set of 33 tools with 30mm bore (or 1-1/4") including spacers and setting gauge.

Product Ref	Bore
IT/MWS/SET081	30mm
IT/MWS/SET087	1-1/4"

Warning this style can only be used on a flush sliding table.

Beading The profile tools in the system can be used for creating the beads, but require changes to the spindle machine settings.

Shared Common Tools When purchasing in conjunction with other styles please see pages 44 & 45.

This system is supplied with a wallchart and individual specification sheets per step. The wallchart can be mounted next to the spindle moulder for quick selection of tools.



Description	Product Ref
Wallchart	WALL/MWS/TFO
Specification Manual	MANU/MWS/TFO



Step 1 Outer Frame Tenon for Jamb to Head

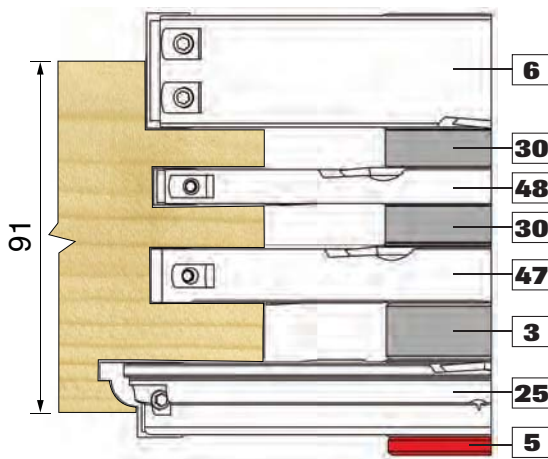

Tools/Spacers			Replacement Knives			
Item No	Product Ref. 30mm (1-1/4")	Description	Size	Product Ref.	Size	Product Ref.
6	IT/7105461(7)	Rebate Head	30x12x1.5	IT/3101230/10	14x14x2.0	IT/3008503/10
30	IT/1920531(7)	Spacer	N/A			
48	IT/71054481(7)	Tenon Head	10x12x1.5	IT/3007507/10	14x14x2.0	IT/3008503/10
47	IT/71054471(7)	Tenon Head	14.6x12x1.5	IT/3108702/10	14x14x2.0	IT/3008503/10
3	IT/1920541(7)	Spacer	N/A			
25	IT/71054251(7)	Ovolo Head	20x23x2.0	IT/3108567	14x14x2.0	IT/3008503/10
5	IT/1920061(7)	Spacer	N/A			

Replacement knives with a /10 are sold in packs of 10.

Alternative profile styles, see pages 41 - 43.

Warning **Recommended Speed 3,500 - 4,500 RPM**

Step 2 to 14 >

Step 2 Outer Frame Tenon for Jamb to Sill

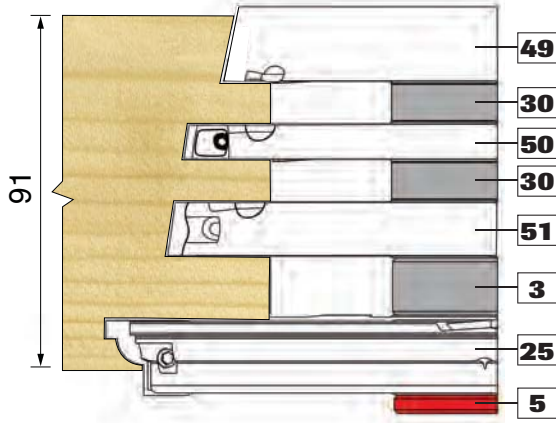

Tools/Spacers			Replacement Knives			
Item No	Product Ref. 30mm (1-1/4")	Description	Size	Product Ref.	Size	Product Ref.
49	IT/71054491(7)	Tenon Disc	19x20x2.0	IT/3108499	14x14x2.0	IT/3008503/10
30	IT/1920531(7)	Spacer	N/A			
50	IT/71054501(7)	Tenon Disc	15x10x2.0	IT/3108520	14x14x2.0	IT/3008503/10
51	IT/71054511(7)	Tenon Disc	18x14.5x2.0	IT/3108521	14x14x2.0	IT/3008503/10
3	IT/1920541(7)	Spacer	N/A			
25	IT/71054251(7)	Ovolo Head	20x23x2.0	IT/3108567	14x14x2.0	IT/3008503/10
5	IT/1920061(7)	Spacer	N/A			

 Alternative profile styles, see pages 41 - 43.



Recommended Speed
3,500 - 4,500 RPM

Step 3 Outer Frame Slots for Head and Sill

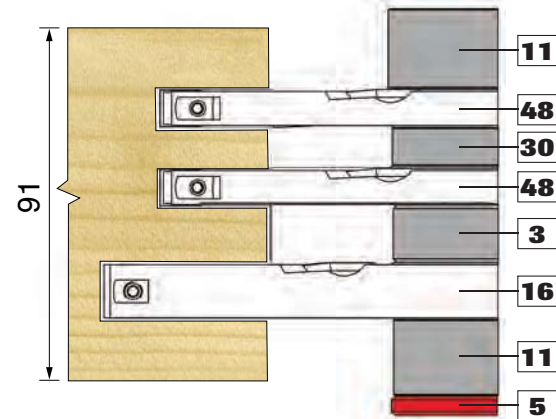

Tools/Spacers			Replacement Knives			
Item No	Product Ref. 30mm (1-1/4")	Description	Size	Product Ref.	Size	Product Ref.
11	IT/1920551(7)	Spacer	N/A			
48	IT/71054481(7)	Tenon Head	9.6x12x1.5	IT/3007507/10	14x14x2.0	IT/3008503/10
30	IT/1920531(7)	Spacer	N/A			
3	IT/1920541(7)	Spacer	N/A			
16	IT/71054161(7)	Tenon Head	14.6x12x1.5	IT/3108702/10	14x14x2.0	IT/3008503/10
5	IT/1920061(7)	Spacer	N/A			



Recommended Speed
3,500 - 4,500 RPM

Step 4 Tenon for Transom and Mullion to Head & Jambs

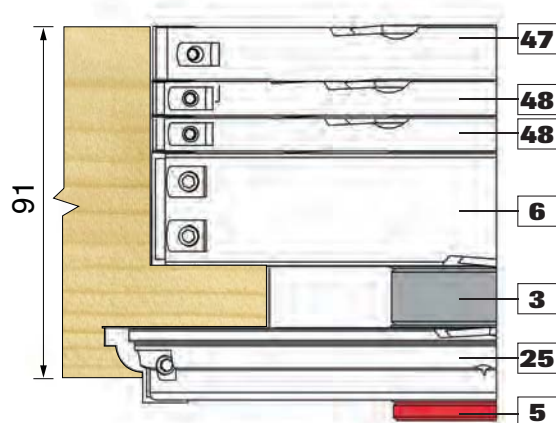

Tools/Spacers			Replacement Knives			
Item No	Product Ref. 30mm (1-1/4")	Description	Size	Product Ref.	Size	Product Ref.
47	IT/71054471(7)	Tenon Head	14.6x12x1.5	IT/3108702/10	14x14x2.0	IT/3008503/10
48	IT/71054481(7)	Tenon Head	10x12x1.5	IT/3007507/10	14x14x2.0	IT/3008503/10
6	IT/7105461(7)	Rebate Head	30x12x1.5	IT/3101230/10	14x14x2.0	IT/3008503/10
3	IT/1920541(7)	Spacer	N/A			
25	IT/71054251(7)	Ovolo Head	20x23x2.0	IT/3108567	14x14x2.0	IT/3008503/10
5	IT/1920061(7)	Spacer	N/A			

 Alternative profile styles, see pages 41 - 43.



Recommended Speed
3,500 - 4,500 RPM

Step 5 Tenon for Mullion to Sill only

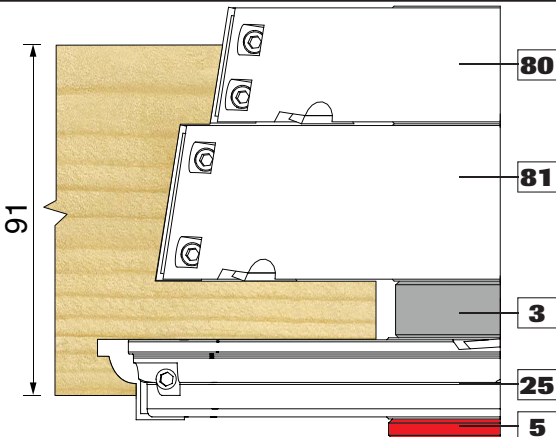

Tools/Spacers			Replacement Knives			
Item No	Product Ref. 30mm (1-1/4")	Description	Size	Product Ref.	Size	Product Ref.
80	IT/71054801(7)	Tenon Head	30x20x2.0	IT/3208050	-	-
81	IT/71054811(7)	Tenon Head	42x19x2.0	IT/3208072	14x14x2.0	IT/3008503/10
3	IT/1920541(7)	Spacer	N/A			
25	IT/71054251(7)	Ovolo Head	20x23x2.0	IT/3108567	14x14x2.0	IT/3008503/10
5	IT/1920061(7)	Spacer	N/A			

Replacement knives with a /10 are sold in packs of 10.

 Alternative profile styles, see pages 41 - 43.



Recommended Speed
3,500 - 4,500 RPM

Step 6 Tenon for Sash Rails

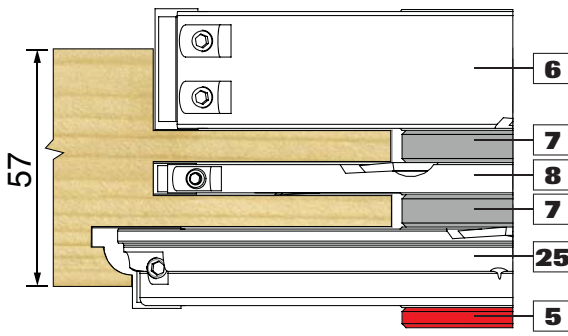

Tools/Spacers			Replacement Knives			
Item No	Product Ref. 30mm (1-1/4")	Description	Size	Product Ref.	Size	Product Ref.
6	IT/7105461(7)	Rebate Head	30x12x1.5	IT/3101230/10	14x14x2.0	IT/3008503/10
7	IT/1927801(7)	Spacer	N/A			
8	IT/7105481(7)	Tenon Head	7.5x12x1.5	IT/3107512/10	14x14x2.0	IT/3008503/10
25	IT/71054251(7)	Ovolo Head	20x23x2.0	IT/3108567	14x14x2.0	IT/3008503/10
5	IT/1920061(7)	Spacer	N/A			

 Alternative profile styles, see pages 41 - 43.



Recommended Speed
3,500 - 4,500 RPM

Step 7 Slots for Sash Stile to Top Rail

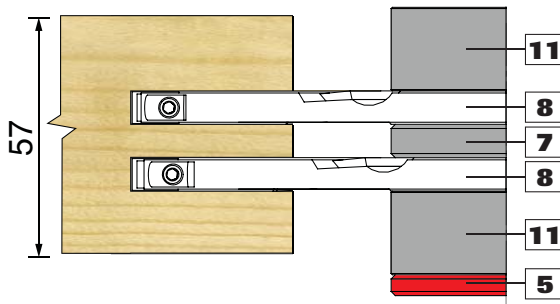

Tools/Spacers			Replacement Knives			
Item No	Product Ref. 30mm (1-1/4")	Description	Size	Product Ref.	Size	Product Ref.
11	IT/1920551(7)	Spacer	N/A			
8	IT/7105481(7)	Tenon Head	7.5x12x1.5	IT/3107512/10	14x14x2.0	IT/3008503/10
7	IT/1927801(7)	Spacer	N/A			
5	IT/1920061(7)	Spacer	N/A			



Recommended Speed
3,500 - 4,500 RPM

Step 8 Slots for Sash Stile to Bottom Rail

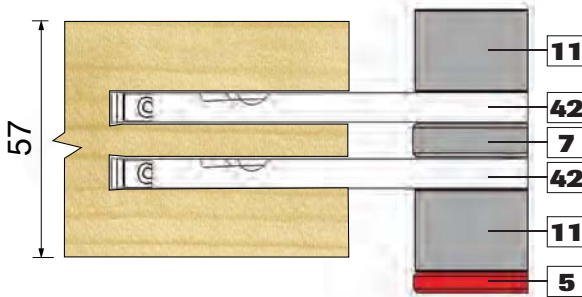

Tools/Spacers			Replacement Knives			
Item No	Product Ref. 30mm (1-1/4")	Description	Size	Product Ref.	Size	Product Ref.
11	IT/1920551(7)	Spacer	N/A			
42	IT/71054421	Tenon Head	7.5x12x1.5	IT/3107512/10	14x14x2.0	IT/3008503/10
7	IT/1927801(7)	Spacer	N/A			
5	IT/1920061(7)	Spacer	N/A			



Recommended Speed
3,500 - 4,500 RPM

Step 9 Outer Frame for Head and Jambs only

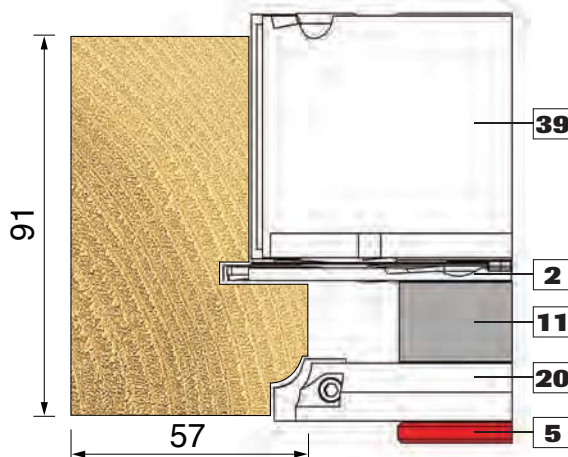

Tools/Spacers			Replacement Knives			
Item No	Product Ref. 30mm (1-1/4")	Description	Size	Product Ref.	Size	Product Ref.
39	IT/71054391(7)	Rebate Head	60x12x1.5	IT/3000531/10	14x14x2.0	IT/3008503/10
2	IT/7105421(7)	Groover	18x18x2.0	IT/3008501/10	14x14x2.0	IT/3008503/10
11	IT/1920551(7)	Spacer	N/A			
20	IT/71054201(7)	Ovolo Head	15x20x2.0	IT/3108627	-	-
5	IT/1920061(7)	Spacer	N/A			

Replacement knives with a /10 are sold in packs of 10.

 Alternative profile styles, see pages 41 - 43.



Recommended Speed
5,500 - 6,500 RPM

HP
Ovolo

HP
20° Splay

HP
TE
Ovolo

TF
Ovolo

SP
Ovolo

SB
YS
Ovolo

EJ
Splay

FS
Splay

DT
Ovolo

DE
Large
Ovolo

Step 10 Mullion Profiling only

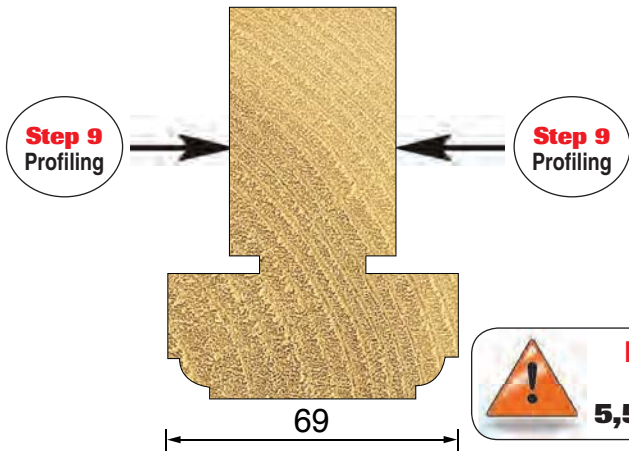

Step 11 Transom Profiling only

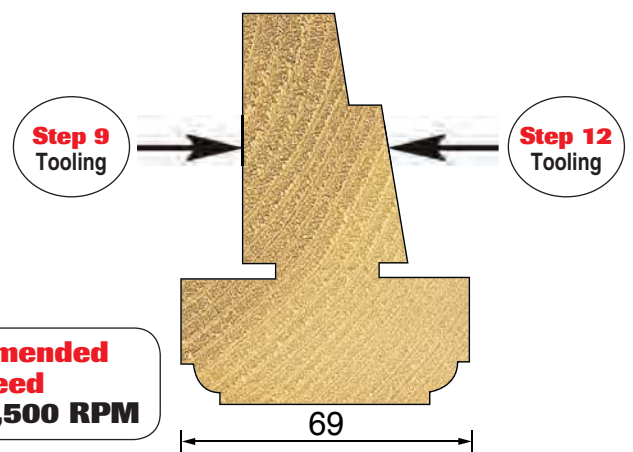

Recommended Speed
5,500 - 6,500 RPM

Step 12 Outer Frame for Sill only

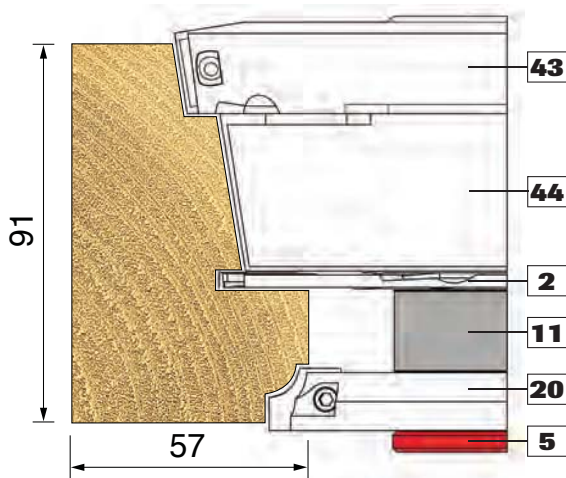

Tools/Spacers			Replacement Knives			
Item No	Product Ref. 30mm (1-1/4")	Description	Size	Product Ref.	Size	Product Ref.
43	IT/71054431(7)	Sill Head	20x12x1.5	IT/3101220/10	14x14x2.0	IT/3008503/10
44	IT/71054441(7)	Sill Head	17x38x2.0	IT/3108498	-	-
2	IT/7105421(7)	Groover	18x18x2.0	IT/3008501/10	14x14x2.0	IT/3008503/10
11	IT/1920551(7)	Spacer	N/A			
20	IT/71054201(7)	Ovolo Head	15x20x2.0	IT/3108627	-	-
5	IT/1920061(7)	Spacer	N/A			



Recommended Speed
5,500 - 6,500 RPM



Alternative profile styles, see pages 41 - 43.

Step 13 Inner Sash Profile

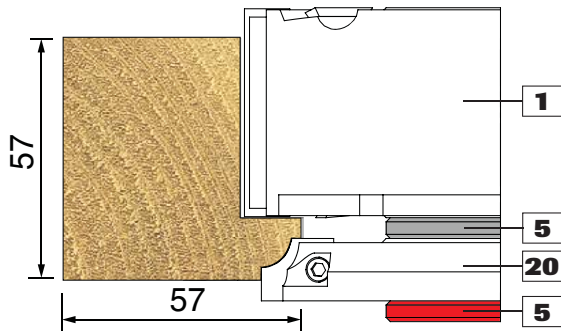

Tools/Spacers			Replacement Knives			
Item No	Product Ref. 30mm (1-1/4")	Description	Size	Product Ref.	Size	Product Ref.
1	IT/7105411(7)	Rebate Head	50x12x1.5	IT/3101250/10	14x14x2.0	IT/3008503/10
5	IT/1920061(7)	Spacer	N/A			
20	IT/71054201(7)	Ovolo Head	15x20x2.0	IT/3108627	-	-



Recommended Speed
5,500 - 6,500 RPM



Alternative profile styles, see pages 41 - 43.

Step 14 Outer Sash Profile for Bottom Rail only

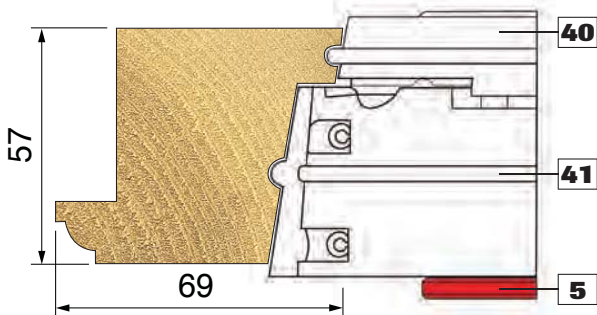

Tools/Spacers			Replacement Knives			
Item No	Product Ref. 30mm (1-1/4")	Description	Size	Product Ref.	Size	Product Ref.
40	IT/71054401	Splay Head	19.5x20x2.0	IT/3108496	-	-
41	IT/71054411	Splay Head	23x45x2.0	IT/3108497	14x14x2.0	IT/3008503/10
5	IT/1920061(7)	Spacer	N/A			



Recommended Speed
5,500 - 6,500 RPM

Replacement knives with a /10 are sold in packs of 10.