

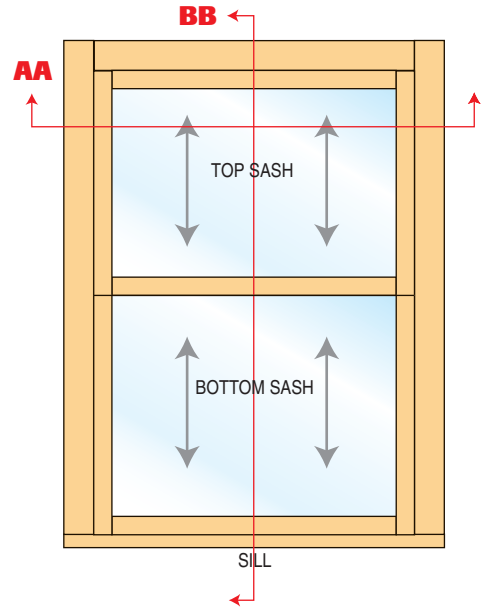

**Top View AA**

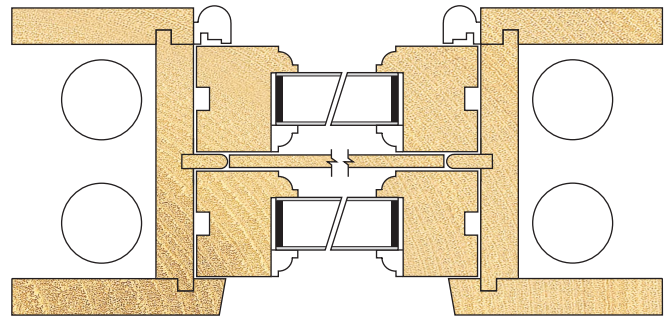

**Side View BB**

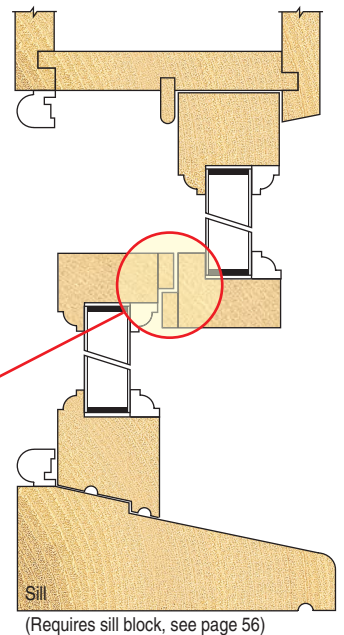

**Timber Sliding Box Sash style windows with the following features:**

- Top sash head and stiles 57mm x 57mm section. Meeting rail 44mm x 57mm section.
- Bottom sash stiles 57mm x 57mm section. Meeting rail 44mm x 57mm section. Bottom rail 69mm x 57mm section.
- Standard ovolo profile on sashes.
- Tooling will make both top and bottom sashes. Tools from the system can be used to produce the box (spindle moulder will need to be re-set).
- All sash joints are combed.
- Will also produce single tenon for putting an optional horn on the top and bottom sashes (mortise hole required).
- 15mm flat on meeting rail to accommodate fastener.
- Produces 15mm x 42mm rebates in the sashes.
- Separate sill block required to run sill section.
- Routing jig also available for producing the slot in the sash for the trickle vent. See page 57.
- Routing jigs also available to produce weight pockets and holes for the pulley wheels. See page 57.

**Optional Section**  
For splayed meeting rails  
- see pages 50 - 53.

**NEW**

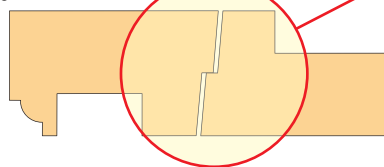

This system is supplied with a wallchart and individual specification sheets per step. The wallchart can be mounted next to the spindle moulder for quick selection of tools.



Description	Product Ref
Wallchart	WALL/MWS/SBS
Specification Manual	MANU/MWS/SBS



**Beading** The profile tools in the system can be used for creating the beads, but require changes to the spindle machine settings.



**Shared Common Tools** When purchasing in conjunction with other styles please see pages 44 & 45.

Complete set of 20 tools with 30mm bore (or 1-1/4") including spacers and setting gauge.

Product Ref	Bore
IT/MWS/SET071	30mm
IT/MWS/SET077	1-1/4"

(Requires sill block, see page 56)

## Step 1 Tenons for Top, Middle & Bottom Rails

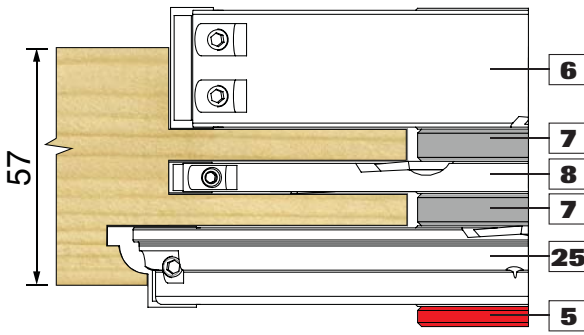

Tools/Spacers			Replacement Knives			
Item No	Product Ref. 30mm (1-1/4")	Description	Size	Product Ref.	Size	Product Ref.
6	IT/7105461(7)	Tenon Head	30x12x1.5	IT/3101230/10	14x14x2.0	IT/3008503/10
7	IT/1927801(7)	Spacer	N/A			
8	IT/7105481(7)	Tenon Head	7.5x12x1.5	IT/3107512/10	14x14x2.0	IT/3008503/10
25	IT/71054251(7)	Ovolo Head	20x23x2.0	IT/3108567	14x14x2.0	IT/3008503/10
5	IT/1920061(7)	Spacer	N/A			

Alternative profile styles, see pages 41 - 43.

Replacement knives with a /10 are sold in packs of 10.



**Recommended Speed**  
**3,500 - 4,500 RPM**

## Step 2 Slots for Top Sash Stiles to Top Rail only

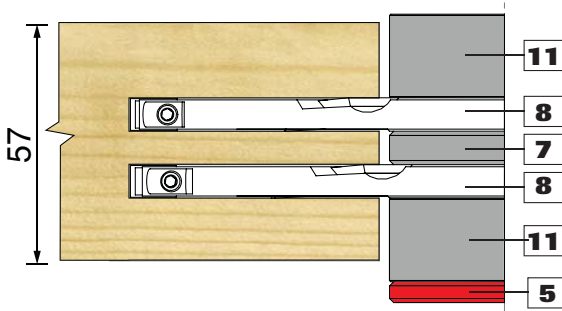

Tools/Spacers			Replacement Knives			
Item No	Product Ref. 30mm (1-1/4")	Description	Size	Product Ref.	Size	Product Ref.
11	IT/1920551(7)	Spacer	N/A			
8	IT/7105481(7)	Tenon Head	7.5x12x1.5	IT/3107512/10	14x14x2.0	IT/3008503/10
7	IT/1927801(7)	Spacer	N/A			
5	IT/1920061(7)	Spacer	N/A			



**Recommended Speed**  
**3,500 - 4,500 RPM**

## Step 3 Slots for Stiles to Meeting Rails only

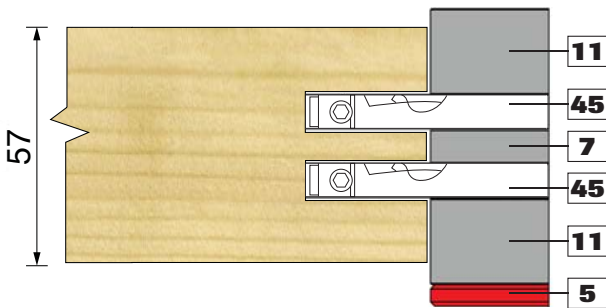

Tools/Spacers			Replacement Knives			
Item No	Product Ref. 30mm (1-1/4")	Description	Size	Product Ref.	Size	Product Ref.
11	IT/1920551(7)	Spacer	N/A			
45	IT/71054451(7)	Tenon Head	7.5x12x1.5	IT/3107512/10	14x14x2.0	IT/3008503/10
7	IT/1927801(7)	Spacer	N/A			
5	IT/1920061(7)	Spacer	N/A			



**Recommended Speed**  
**3,500 - 4,500 RPM**

## ALTERNATIVELY

### Step 3a Tenon Joint when Horns are required

### Optional

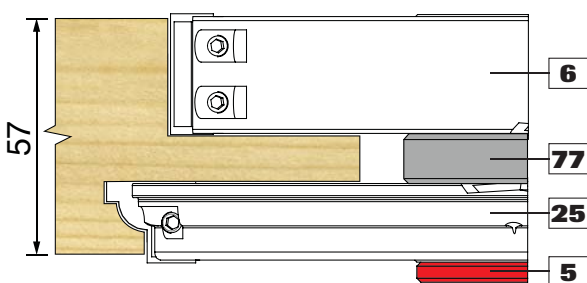

Tools/Spacers			Replacement Knives			
Item No	Product Ref. 30mm (1-1/4")	Description	Size	Product Ref.	Size	Product Ref.
6	IT/7105461(7)	Tenon Head	30x12x1.5	IT/3101230/10	14x14x2.0	IT/3008503/10
77	IT/1920871(7)	Spacer	N/A			
25	IT/71054251(7)	Ovolo Head	20x23x2.0	IT/3108567	14x14x2.0	IT/3008503/10
5	IT/1920061(7)	Spacer	N/A			

Alternative profile styles, see pages 41 - 43.



**Recommended Speed**  
**3,500 - 4,500 RPM**

HP  
Ovolo

HP  
20° Splay

HP  
TF  
Ovolo

TF  
Ovolo

SP  
Ovolo

SB  
XS  
Ovolo

EJ  
9° Splay

FS  
9° Splay

DT  
Ovolo

DE  
Large  
Ovolo

## Step 4 Slots for Stiles to Bottom Rail only

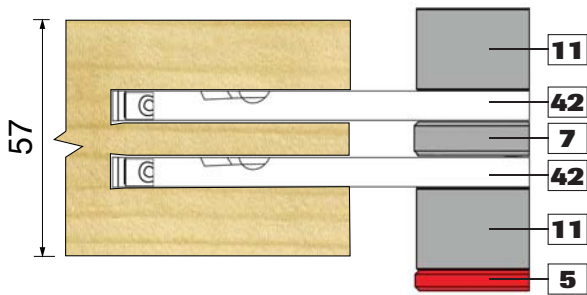

Tools/Spacers			Replacement Knives			
Item No	Product Ref. 30mm (1-1/4")	Description	Size	Product Ref.	Size	Product Ref.
11	IT/1920551(7)	Spacer	N/A			
42	IT/71054421(7)	Tenon Head	7.5x12x1.5	IT/3107512/10	14x14x2.0	IT/3008503/10
7	IT/1927801(7)	Spacer	N/A			
5	IT/1920061(7)	Spacer	N/A			



**Recommended Speed**

**3,500 - 4,500 RPM**

## Step 5 Profile Inner Sash (apart from Top Sash Meeting Rail)

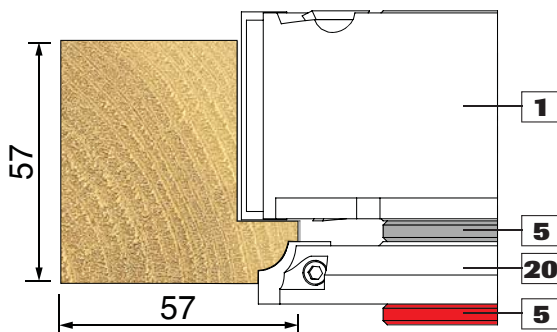

Tools/Spacers			Replacement Knives			
Item No	Product Ref. 30mm (1-1/4")	Description	Size	Product Ref.	Size	Product Ref.
1	IT/7105411(7)	Rebate Head	50x12x1.5	IT/3101250/10	14x14x2.0	IT/3008503/10
5	IT/1920061(7)	Spacer	N/A			
20	IT/71054201(7)	Ovolo Head	15x20x2.0	IT/3108627	-	-



Alternative profile styles, see pages 41 - 43.



**Recommended Speed**

**5,500 - 6,500 RPM**

## Step 6 Profile Inner Sash (Top Sash Meeting Rail only)

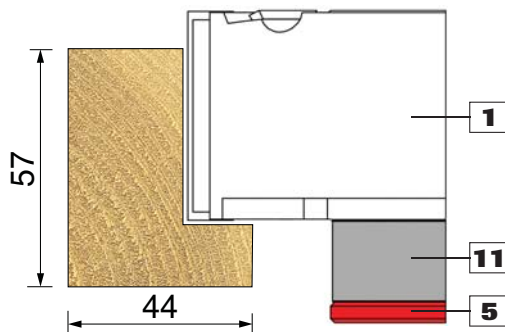

Tools/Spacers			Replacement Knives			
Item No	Product Ref. 30mm (1-1/4")	Description	Size	Product Ref.	Size	Product Ref.
1	IT/7105411(7)	Rebate Head	50x12x1.5	IT/3101250/10	14x14x2.0	IT/3008503/10
11	IT/1920551(7)	Spacer	N/A			
5	IT/1920061(7)	Spacer	N/A			



**Recommended Speed**

**5,500 - 6,500 RPM**

## Step 7 Profile Outer Sash Bottom Rail only

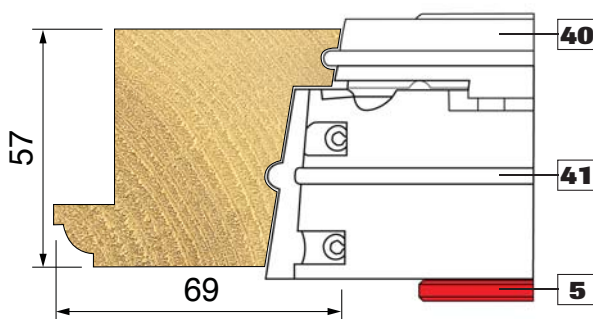

Tools/Spacers			Replacement Knives			
Item No	Product Ref. 30mm (1-1/4")	Description	Size	Product Ref.	Size	Product Ref.
40	IT/71054401(7)	Splay Head	19.5x20x2.0	IT/3108496	-	-
41	IT/71054411(7)	Splay Head	23x45x2.0	IT/3108497	14x14x2.0	IT/3008503/10
5	IT/1920061(7)	Spacer	N/A			



**Recommended Speed**

**5,500 - 6,500 RPM**

Replacement knives with a /10 are sold in packs of 10.

HP  
Ovolo

HP  
20° Splay

HP  
TE  
Ovolo

TF  
Ovolo

SP  
Ovolo

SB  
XS  
Ovolo

EJ  
MA  
q Splay

FS  
q Splay

DT  
Ovolo

DE  
Large  
Ovolo