

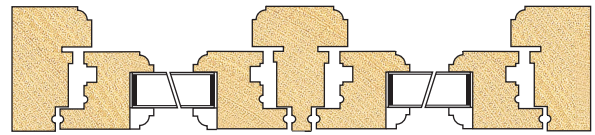

Top View AA

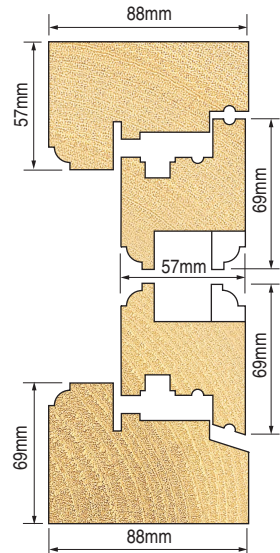

Dimensions



Side View BB

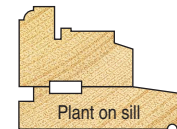
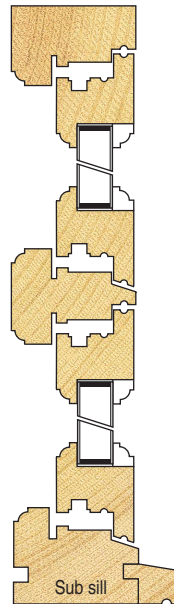

For tooling for production of the sill, please see page 56.

Timber High Performance Traditional Flush style windows with the following features:

- Outer frame head and jamb section 88mm x 57mm. Outer frame sill section 88mm x 69mm. Sash section 69mm x 57mm.
- Combines the look of a Traditional Flush window with the security and weather sealing advantages of a High Performance window.
- Standard ovolo profile on outer frame and sash.
- All outer frame and sash joints are combed.
- Will also produce single tenon for mullion and transom joints (mortise hole required).
- Euro groove for high security espagnolette locking system.
- Special frame and sash design conceals view of ironmongery from outside the window.
- Locating check for top-hung or side-hung friction stays and locked night vent position.
- Can also accommodate egress friction hinges allowing windows to conform to building regulations.
- 4mm groove width in outer frame to accept standard weather seals.
- Produces 18mm rebate depths in outer frame and 18mm x 42mm rebates in the sash.
- Separate routing jig available for producing a mortise for the espagnolette lock body.
- Routing jig also available for producing the slot in the sash for the trickle vent.

See page 24 for extra machining step for fire escape/Egress hinges.

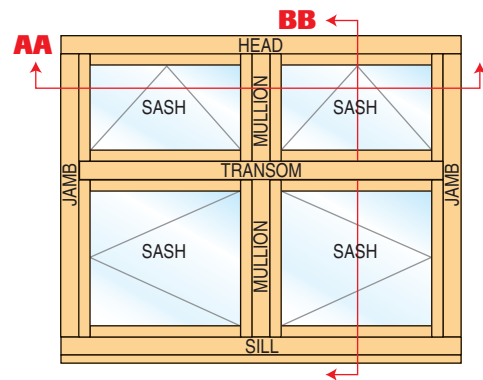

This system is supplied with a wallchart and individual specification sheets per step. The wallchart can be mounted next to the spindle moulder for quick selection of tools.



Description

Wallchart
Specification Manual

Product Ref

WALL/MWS/HPTF
MANU/MWS/HPTF



Beading The profile tools in the system can be used for creating the beads, but require changes to the spindle machine settings.



Shared Common Tools When purchasing in conjunction with other styles please see pages 44 & 45.

Complete set of 44 tools with 30mm bore (or 1-1/4") including spacers and setting gauge.

Product Ref

IT/MWS/SET031
IT/MWS/SET037

Bore

30mm
1-1/4"

Step 1 Tenon Tools for Outer Frame Jambs to Head

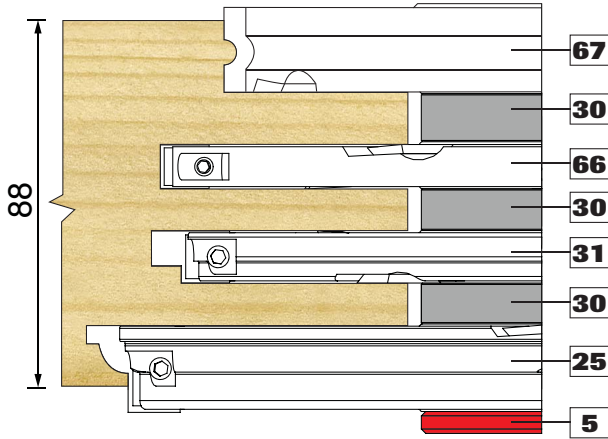

Tools/Spacers			Replacement Knives			
Item No	Product Ref. 30mm (1-1/4")	Description	Size	Product Ref.	Size	Product Ref.
67	IT/71054671(7)	Tenon Head	30x22x2.0	IT/3208052	14x14x2.0	IT/3008503/10
30	IT/1920531(7)	Spacer	N/A			
66	IT/71054661(7)	Tenon Head	11.6x12x1.5	IT/3007509/10	14x14x2.0	IT/3008503/10
31	IT/71054311(7)	Groover	19x11x6.2	IT/3108577	14x14x2.0	IT/3008503/10
25	IT/71054251(7)	Ovolo Head	20x23x2.0	IT/3108567	14x14x2.0	IT/3008503/10
5	IT/1920061(7)	Spacer	N/A			

 Alternative profile styles, see pages 41 - 43.



Recommended Speed
3,500 - 4,500 RPM

Replacement knives with a /10 are sold in packs of 10.

Step 2 Tenon Tools for Outer Frame Jambs to Sill

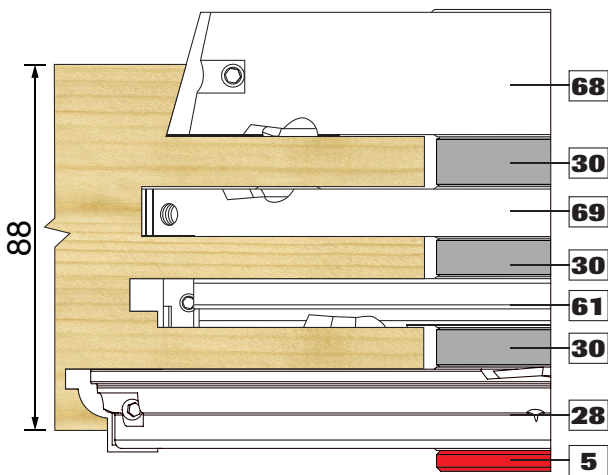

Tools/Spacers			Replacement Knives			
Item No	Product Ref. 30mm (1-1/4")	Description	Size	Product Ref.	Size	Product Ref.
68	IT/71054681(7)	Tenon Head	30x22x2.0	IT/3208053	14x14x2.0	IT/3008503/10
30	IT/1920531(7)	Spacer	N/A			
69	IT/71054691(7)	Tenon Head	11.6x12x1.5	IT/3007509/10	14x14x2.0	IT/3008503/10
61	IT/71054611	Groover	19x11x6.2	IT/3108577	14x14x2.0	IT/3008503/10
28	IT/71054281(7)	Ovolo Head	20x23x2.0	IT/3108567	14x14x2.0	IT/3008503/10
5	IT/1920061(7)	Spacer	N/A			

 Alternative profile styles, see pages 41 - 43.



Recommended Speed
3,500 - 4,500 RPM

Step 3 Slot Tenons for Outer Frame Head & Sill

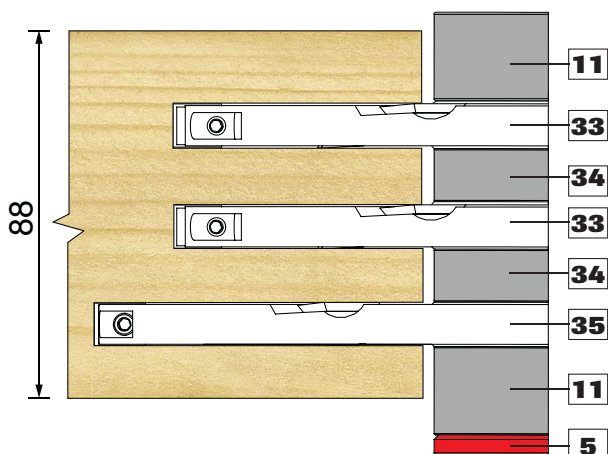

Tools/Spacers			Replacement Knives			
Item No	Product Ref. 30mm (1-1/4")	Description	Size	Product Ref.	Size	Product Ref.
11	IT/1920551(7)	Spacer	N/A			
33	IT/71054331(7)	Tenon Head	9.6x12x1.5	IT/3007507/10	14x14x2.0	IT/3008503/10
34	IT/1920471(7)	Spacer	N/A			
35	IT/71054351(7)	Tenon Head	9.6x12x1.5	IT/3007507/10	14x14x2.0	IT/3008503/10
5	IT/1920061(7)	Spacer	N/A			



Recommended Speed
3,500 - 4,500 RPM

HP
Ovolo

HP
20° Splain

HP
TE
Ovolo

TF
Ovolo

SP
Ovolo

SB
YS
Ovolo

EJ
M
q Splain

FS
q Splain

DT
Ovolo

DE
Large
Ovolo

Step 4 Scribe & Tenon for Mullions & Transoms to Head & Jamb

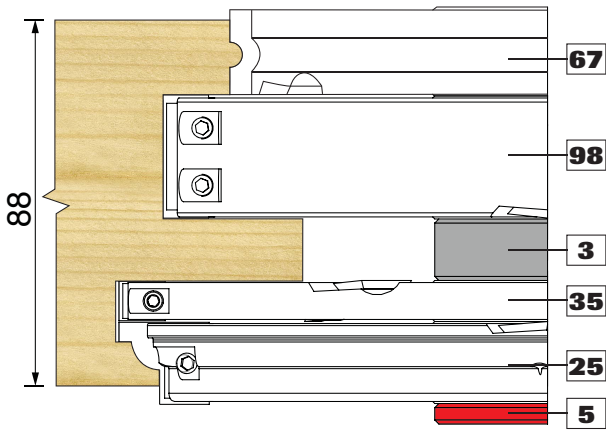

Tools/Spacers			Replacement Knives			
Item No	Product Ref. 30mm (1-1/4")	Description	Size	Product Ref.	Size	Product Ref.
67	IT/71054671(7)	Tenon Head	20x19.5x2.0	IT/3208052	14x14x2.0	IT/3008503/10
98	IT/71054981(7)	Tenon Head	30x12x1.5	IT/3208158	14x14x2.0	IT/3008503/10
3	IT/1920541(7)	Spacer	N/A			
35	IT/71054351(7)	Tenon Head	9.6x12x1.5	IT/3007507/10	14x14x2.0	IT/3008503/10
25	IT/71054251(7)	Ovolo Head	20x23x2.0	IT/3108567	14x14x2.0	IT/3008503/10
5	IT/1920061(7)	Spacer	N/A			

 Alternative profile styles, see pages 41 - 43.



Recommended Speed
3,500 - 4,500 RPM

Step 5 Scribe & Tenon for Mullion to Sill

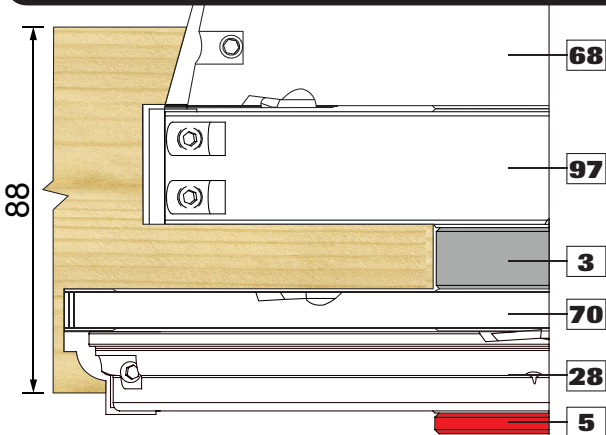

Tools/Spacers			Replacement Knives			
Item No	Product Ref. 30mm (1-1/4")	Description	Size	Product Ref.	Size	Product Ref.
68	IT/71054681(7)	Tenon Head	30x22x2.0	IT/3208053	14x14x2.0	IT/3008503/10
97	IT/71054971(7)	Tenon Head	30x12x1.5	IT/3208158	14x14x2.0	IT/3008503/10
3	IT/1920541(7)	Spacer	N/A			
70	IT/71054701(7)	Tenon Head	9.6x12x1.5	IT/3007507/10	14x14x2.0	IT/3008503/10
28	IT/71054281(7)	Ovolo Head	20x23x2.0	IT/3108567	14x14x2.0	IT/3008503/10
5	IT/1920061(7)	Spacer	N/A			

 Alternative profile styles, see pages 41 - 43.

Replacement knives with a /10 are sold in packs of 10.



Recommended Speed
3,500 - 4,500 RPM

Step 6 Tenon for Sash Rails

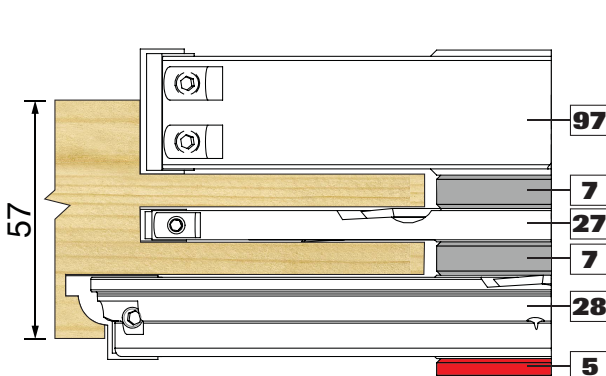

Tools/Spacers			Replacement Knives			
Item No	Product Ref. 30mm (1-1/4")	Description	Size	Product Ref.	Size	Product Ref.
97	IT/71054791(7)	Tenon Head	30x12x1.5	IT/3208158	14x14x2.0	IT/3008503/10
7	IT/1927801(7)	Spacer	N/A			
27	IT/71054271(7)	Tenon Head	7.5x12x1.5	IT/3107512/10	14x14x2.0	IT/3008503/10
28	IT/71054281(7)	Ovolo Head	20x23x2.0	IT/3108567	14x14x2.0	IT/3008503/10
5	IT/1920061(7)	Spacer	N/A			

 Alternative profile styles, see pages 41 - 43.



Recommended Speed
3,500 - 4,500 RPM

HP
Ovolo

HP
20° Splay

HP
TF
Ovolo

TF
Ovolo

SP
Ovolo

SB
YS
Ovolo

EJ
15° Splay

FS
9° Splay

DT
Ovolo

DE
Large
Ovolo

Step 7 Slots for Sash Stiles

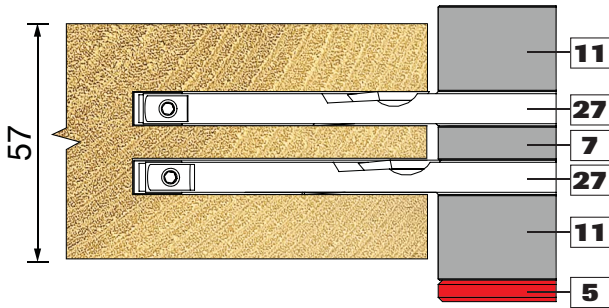

Tools/Spacers			Replacement Knives			
Item No	Product Ref. 30mm (1-1/4")	Description	Size	Product Ref	Size	Product Ref
11	IT/1920551(7)	Spacer	N/A			
27	IT/71054271(7)	Tenon Head	7.5x12x1.5	IT/3107512/10	14x14x2.0	IT/3008503/10
7	IT/1927801(7)	Spacer	N/A			
5	IT/1920061(7)	Spacer	N/A			



Recommended Speed

3,500 - 4,500 RPM

Step 8 Outer Frame Profile for Head & Jambs only

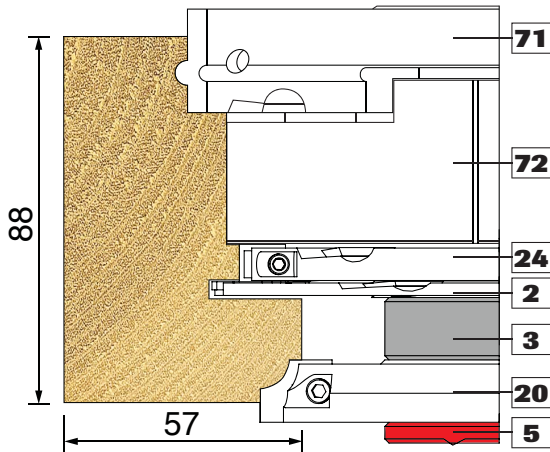

Tools/Spacers			Replacement Knives			
Item No	Product Ref. 30mm (1-1/4")	Description	Size	Product Ref	Size	Product Ref
71	IT/71054711(7)	Rebate Head	25x21x2.0	IT/3208054	14x14x2.0	IT/3008503/10
72	IT/71054721(7)	Planer Head	40x12x1.5	IT/3000528/10	14x14x2.0	IT/3008503/10
24	IT/71054241(7)	Planer Head	9.0x12x1.5	IT/3108474/10	-	-
2	IT/7105421(7)	Groover	18x18x2.0	IT/3008501/10	14x14x2.0	IT/3008503/10
3	IT/1920541(7)	Spacer	N/A			
20	IT/71054201(7)	Ovolo Head	15x20x2.0	IT/3108627	-	-
5	IT/1920061(7)	Spacer	N/A			

Alternative profile styles, see pages 41 - 43.

Replacement knives with a /10 are sold in packs of 10.



Recommended Speed

5,500 - 6,500 RPM

Step 9 Mullion Profiling only

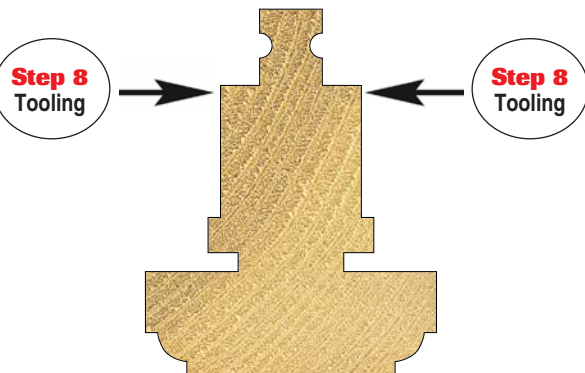

Recommended Speed

5,500 - 6,500 RPM

Step 10 Transom Profiling only

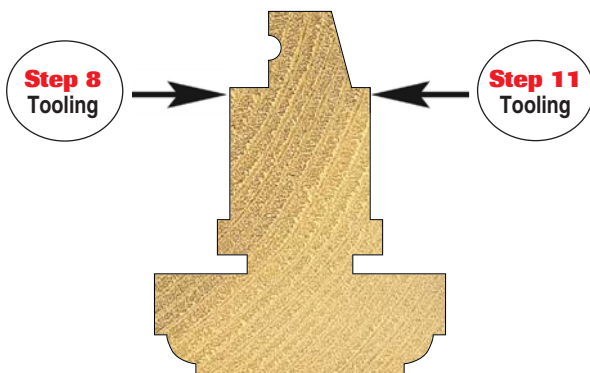

Recommended Speed

5,500 - 6,500 RPM



Step 11 Outer Frame Profile for Sill only

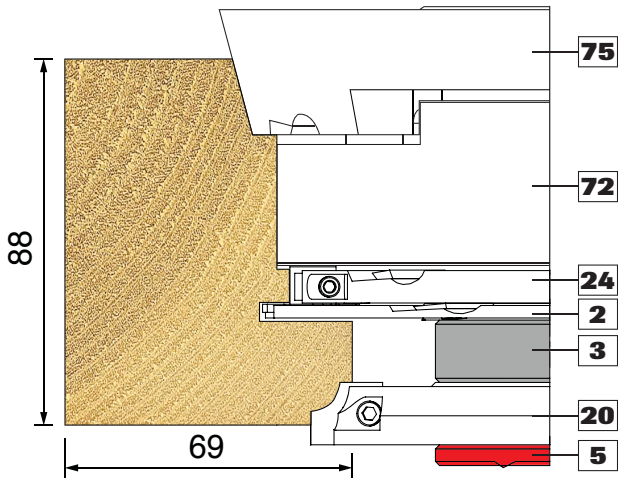

Tools/Spacers			Replacement Knives			
Item No	Product Ref. 30mm (1-1/4")	Description	Size	Product Ref	Size	Product Ref
75	IT/71054751(7)	Rebate Head	30x22x2.0	IT/3208057	14x14x2.0	IT/3008503/10
72	IT/71054721(7)	Planer Head	40x12x1.5	IT/3000528/10	14x14x2.0	IT/3008503/10
24	IT/71054241(7)	Planer Head	9.0x12x1.5	IT/3108474/10	-	-
2	IT/7105421(7)	Groover	18x18x2.0	IT/3008501/10	14x14x2.0	IT/3008503/10
3	IT/1920541(7)	Spacer	N/A			
20	IT/71054201(7)	Ovolo Head	15x20x2.0	IT/3108627	-	-
5	IT/1920061(7)	Spacer	N/A			

Alternative profile styles, see pages 41 to 43.



Recommended Speed

5,500 - 6,500 RPM

Step 12 Sash Inner Profile

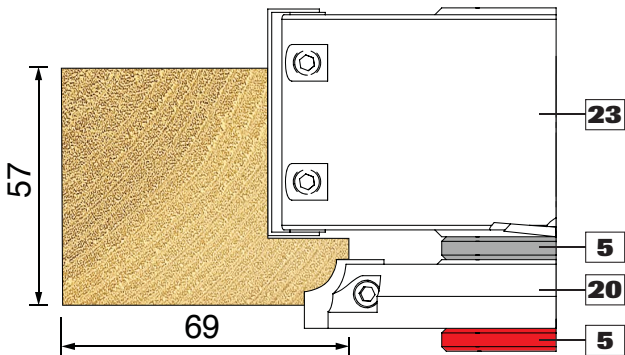

Tools/Spacers			Replacement Knives			
Item No	Product Ref. 30mm (1-1/4")	Description	Size	Product Ref	Size	Product Ref
23	IT/71054231(7)	Rebate Head	50x12x1.5	IT/3101250/10	14x14x2.0	IT/3008503/10
5	IT/1920061(7)	Spacer	N/A			
20	IT/71054201(7)	Ovolo Head	20x20x2.0	IT/3108627	-	-

Alternative profile styles, see pages 41 - 43.



Recommended Speed

5,500 - 6,500 RPM

Step 13 Sash Outer Profile for Stiles & Top Rails only

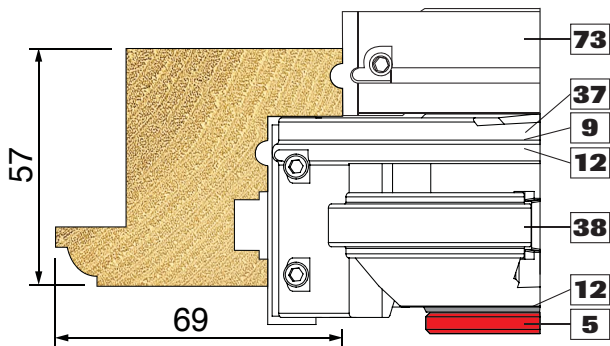

Tools/Spacers			Replacement Knives			
Item No	Product Ref. 30mm (1-1/4")	Description	Size	Product Ref	Size	Product Ref
73	IT/71054731(7)	Rebate Head	25x18x2.0	IT/3208055	-	-
37	IT/71054371(7)	Rebate Head	50x12x1.5	IT/3108600	14x14x2.0	IT/3008503/10
9	IT/1927101(7)	Spacer	N/A			
12	IT/1927201(7)	Spacer	N/A			
38	IT/71054381(7)	Euro Groove	19x16.3x2	IT/3108601	-	-
5	IT/1920061(7)	Spacer	N/A			



Recommended Speed

5,500 - 6,500 RPM

Step 14 Sash Outer Profile for Bottom Rail only

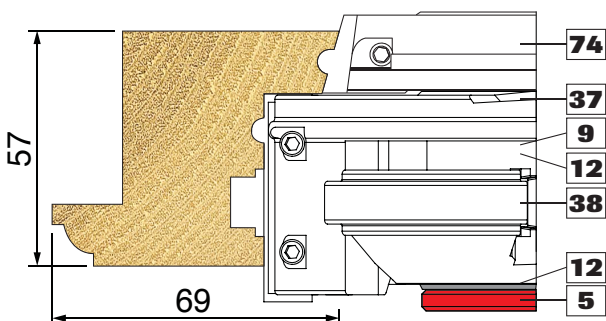

Tools/Spacers			Replacement Knives			
Item No	Product Ref. 30mm (1-1/4")	Description	Size	Product Ref	Size	Product Ref
74	IT/71054741(7)	Rebate Head	20x21x2.0	IT/3208056	-	-
37	IT/71054371(7)	Rebate Head	50x12x1.5	IT/3108600	14x14x2.0	IT/3008503/10
9	IT/1927101(7)	Spacer	N/A			
12	IT/1927201(7)	Spacer	N/A			
38	IT/71054381(7)	Euro Groove	19x16.3x2	IT/3108601	-	-
5	IT/1920061(7)	Spacer	N/A			



Recommended Speed

5,500 - 6,500 RPM

Extra Machining Step - Fire Escape/Egress Hinges



- In order for fire escape/Egress type hinges to work correctly in the HPTF window, an extra machining step must be run.
 - Step 15 is run on the outer sash on the two sides (both stiles or top and bottom rail) where the fire escape/Egress hinges are to be fixed.
 - See illustration for correct hinge fixing location.
 - Some manufacturers hinges may require a different location point in the outer frame and sash.
- Please contact us for more details.

- HP Oval
- HP 20° Splay
- HP TF Oval
- TF Oval
- SP Oval
- SB YS Oval
- EJ M Splay
- FS Splay
- DT Oval
- DE Large Oval

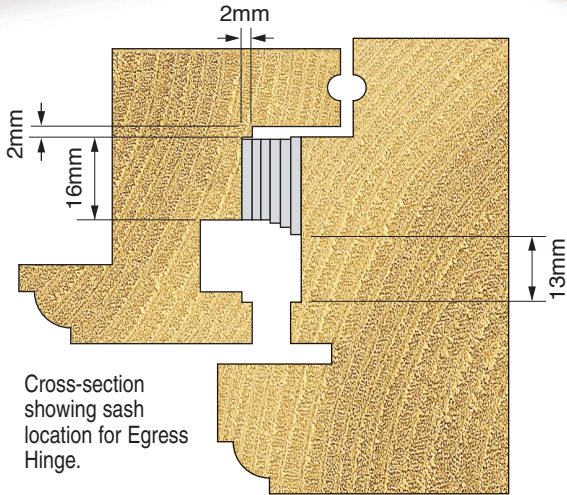

Step 15 Sash Outer Groove for Stiles or Top Bottom Rail

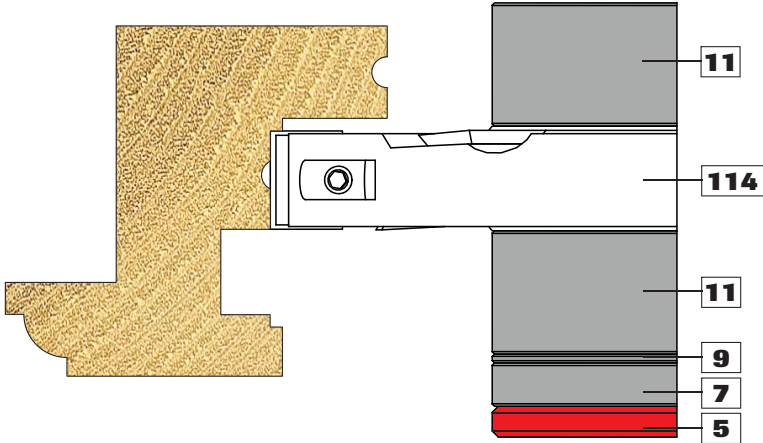

Recommended Speed
5,500 - 6,500 RPM