

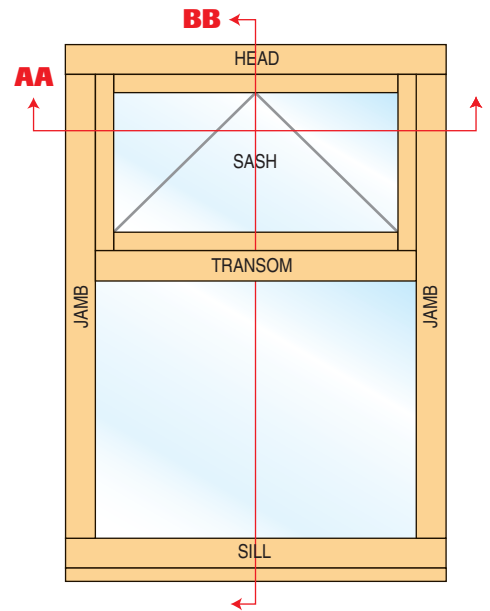

Top View AA

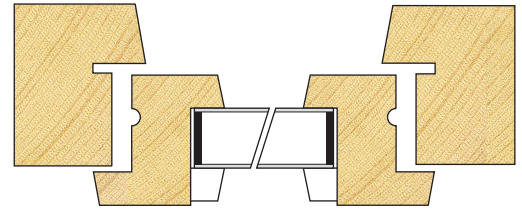

Side View BB

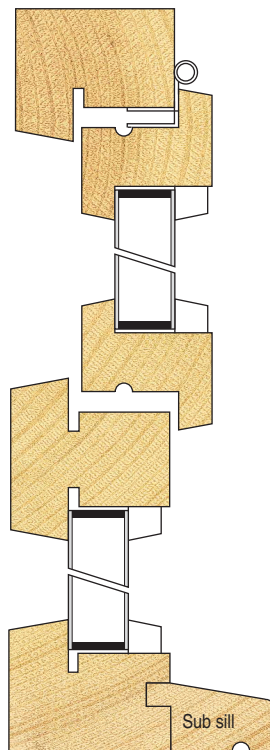

(Requires sill block, see page 56)

Dimensions

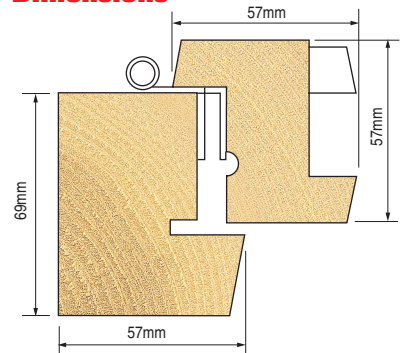

Timber Full Splay 9° style windows with the following features:

- Outer frame section 69mm x 57mm. Sash section 57mm x 57mm.
- Standard 9 degree full splay profile on outer frame and sash.
- All outer frame and sash joints are combed.
- Will also produce single tenon for mullion and transom joints (mortise hole required).
- Uses standard cranked hinges, fasteners and stays.
- 4mm groove width in outer frame to accept standard weather seals. Alternative 3mm groove width can be produced - see page 55.
- Produces 15mm rebate depths in outer frame.
- Produces 15mm x 42mm rebates in the sash.
- Routing jig also available for producing the slot in the sash for the trickle vent. See page 57.



This system is supplied with a wallchart and individual specification sheets per step. The wallchart can be mounted next to the spindle moulder for quick selection of tools.



Description	Product Ref
Wallchart	WALL/MWS/FS9
Specification Manual	MANU/MWS/FS9



Beading The profile tools in the system can be used for creating the beads, but require changes to the spindle machine settings.



Shared Common Tools When purchasing in conjunction with other styles please see pages 44 & 45.

Complete set of 23 tools with 30mm bore (or 1-1/4") including spacers and setting gauge.

Product Ref	Bore
IT/MWS/SET041	30mm
IT/MWS/SET047	1-1/4"

Step 1 Tenon Tools for Outer Frame

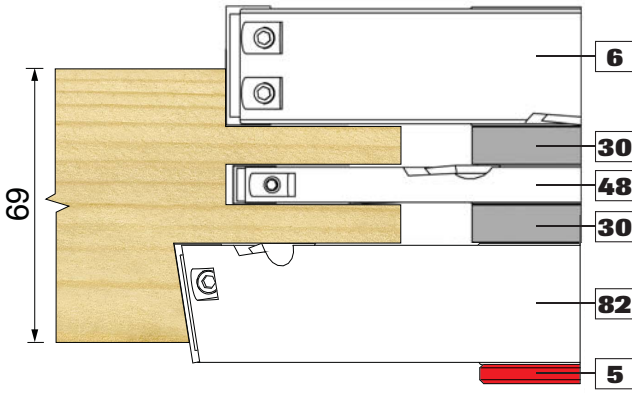

Tools/Spacers			Replacement Knives			
Item No	Product Ref. 30mm (1-1/4")	Description	Size	Product Ref.	Size	Product Ref.
6	IT/7105461(7)	Rebate Head	30x12x1.5	IT/3101230/10	14x14x2.0	IT/3008503/10
30	IT/1920531(7)	Spacer	N/A			
48	IT/71054481(7)	Tenon Head	9.6x12x1.5	IT/3007507/10	14x14x2.0	IT/3008503/10
82	IT/71054821(7)	9° Tenon Disc	20x30x2.0	IT/3208137	14x14x2.0	IT/3008503/10
5	IT/1920061(7)	Spacer	N/A			

Replacement knives with a /10 are sold in packs of 10.



Recommended Speed
3,500 - 4,500 RPM

Step 2 Outer Frame Slots for Head and Sill

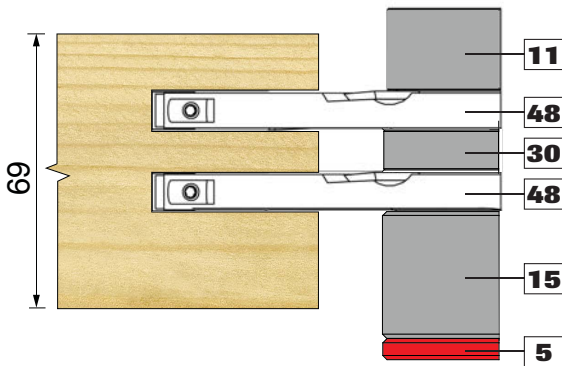

Tools/Spacers			Replacement Knives			
Item No	Product Ref. 30mm (1-1/4")	Description	Size	Product Ref.	Size	Product Ref.
11	IT/1920551(7)	Spacer	N/A			
48	IT/71054481(7)	Tenon Head	9.6x12x1.5	IT/3007507/10	14x14x2.0	IT/3008503/10
30	IT/1920531(7)	Spacer	N/A			
15	IT/1920561(7)	Spacer	N/A			
5	IT/1920061(7)	Spacer	N/A			



Recommended Speed
3,500 - 4,500 RPM

Step 3 Tenon for Outer Frame Transoms & Mullions

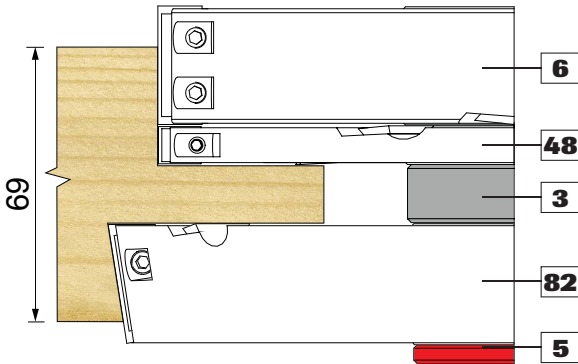

Tools/Spacers			Replacement Knives			
Item No	Product Ref. 30mm (1-1/4")	Description	Size	Product Ref.	Size	Product Ref.
6	IT/7105461(7)	Rebate Head	30x12x1.5	IT/3101230/10	14x14x2.0	IT/3008503/10
48	IT/71054481(7)	Tenon Head	9.6x12x1.5	IT/3007507/10	14x14x2.0	IT/3008503/10
3	IT/1920541(7)	Spacer	N/A			
82	IT/71054821(7)	9° Tenon Disc	20x30x2.0	IT/3208137	14x14x2.0	IT/3008503/10
5	IT/1920061(7)	Spacer	N/A			



Recommended Speed
3,500 - 4,500 RPM

Step 4 Tenon for Sash Rails

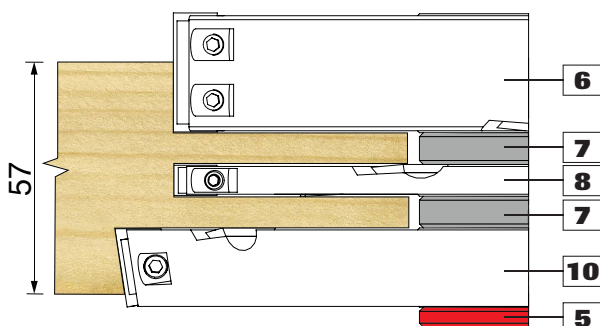

Tools/Spacers			Replacement Knives			
Item No	Product Ref. 30mm (1-1/4")	Description	Size	Product Ref.	Size	Product Ref.
6	IT/7105461(7)	Tenon Head	30x12x1.5	IT/3101230/10	14x14x2.0	IT/3008503/10
7	IT/1927801(7)	Spacer	N/A			
8	IT/71054481(7)	Tenon Head	7.5x12x1.5	IT/3107512/10	14x14x2.0	IT/3008503/10
10	IT/71054101(7)	Bevel Head	20x12x1.5	IT/3108624	14x14x2.0	IT/3008503/10
5	IT/1920061(7)	Spacer	N/A			



Recommended Speed
3,500 - 4,500 RPM

Step 5 to 8 >



Step 5 Slots for Sash Stiles

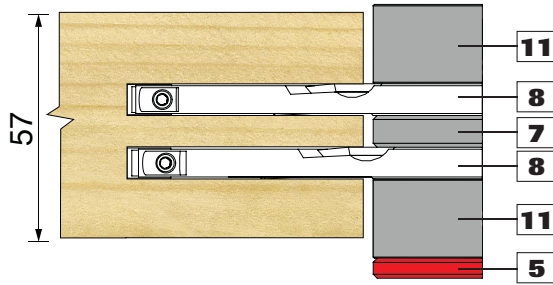

Tools/Spacers			Replacement Knives			
Item No	Product Ref. 30mm (1-1/4")	Description	Size	Product Ref.	Size	Product Ref.
11	IT/1920551(7)	Spacer	N/A			
8	IT/7105481(7)	Tenon Head	7.5x12x1.5	IT/3107512/10	14x14x2.0	IT/3008503/10
7	IT/1927801(7)	Spacer	N/A			
5	IT/1920061(7)	Spacer	N/A			

Replacement knives with a /10 are sold in packs of 10.



Recommended Speed
3,500 - 4,500 RPM

Step 6 Outer Frame Profile

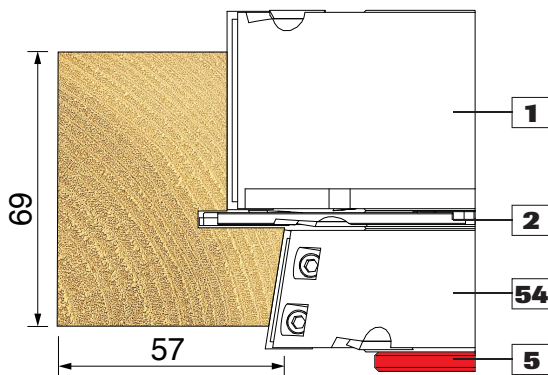

Tools/Spacers			Replacement Knives			
Item No	Product Ref. 30mm (1-1/4")	Description	Size	Product Ref.	Size	Product Ref.
1	IT/7105411(7)	Rebate Head	50x12x1.5	IT/3101250/10	14x14x2.0	IT/3008503/10
2	IT/7105421(7)	Groover	18x18x2.0	IT/3008501/10	14x14x2.0	IT/3008503/10
54	IT/71054541(7)	9° Profile Head	30x22x2.0	IT/3208199	-	-
5	IT/1920061(7)	Spacer	N/A			



Recommended Speed
5,500 - 6,500 RPM

Step 7 Inner Sash Profile

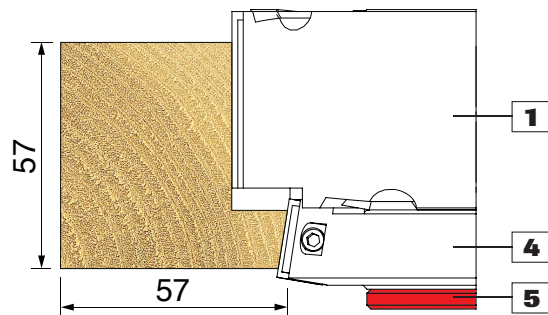

Tools/Spacers			Replacement Knives			
Item No	Product Ref. 30mm (1-1/4")	Description	Size	Product Ref.	Size	Product Ref.
1	IT/7105411(7)	Rebate Head	50x12x1.5	IT/3101250/10	14x14x2.0	IT/3008503/10
4	IT/7105441(7)	Bevel Head	20x12x1.5	IT/3101220/10	-	-
5	IT/1920061(7)	Spacer	N/A			



Recommended Speed
5,500 - 6,500 RPM

Step 8 Outer Sash Profile

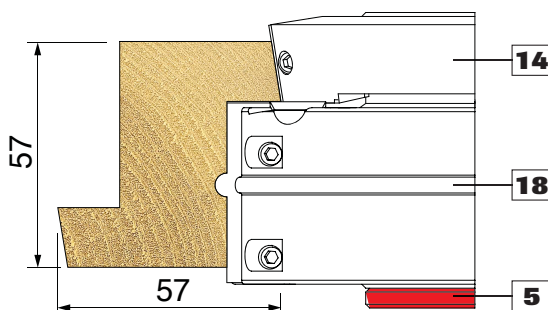

Tools/Spacers			Replacement Knives			
Item No	Product Ref. 30mm (1-1/4")	Description	Size	Product Ref.	Size	Product Ref.
14	IT/7105411(7)	Bevel Head	20x12x1.5	IT/3101220/10	-	-
18	IT/71054181(7)	Rebate Head	47x20x2.0	IT/3108626	14x14x2.0	IT/3008503/10
5	IT/1920061(7)	Spacer	N/A			

Replacement knives with a /10 are sold in packs of 10.



Recommended Speed
5,500 - 6,500 RPM

