

# AQUAMAC™ 63 WEATHERSEAL

## CASEMENT WINDOWS

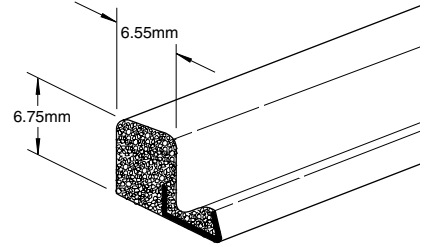

### PERFORMANCE BENEFITS

- Returns to original shape after compression.
- Stretching and shrink back at corners avoided.
- Insert retention leg enables fast and effective insertion.
- Low compression force helps ease window and door operation.
- Maintains weathering characteristics and resists compression set over a wide temperature range +70°C to -30°C.
- Research has proved that Aquamac™ Weatherseal gives high levels of sound reduction.
- Unaffected by paint, stains, rot, fungi, UV light and ozone.
- Supplied in white or brown as standard.
- Suitable for all main timber window and door types.

Colour	Approximate Length	Order Ref.
White	10 metres	AQ63/W/10
White	25 metres	AQ63/W/25
White	300 metre roll	AQ63/W/300
Brown	10 metres	AQ63/B/10
Brown	25 metres	AQ63/B/25
Brown	300 metre roll	AQ63/B/300

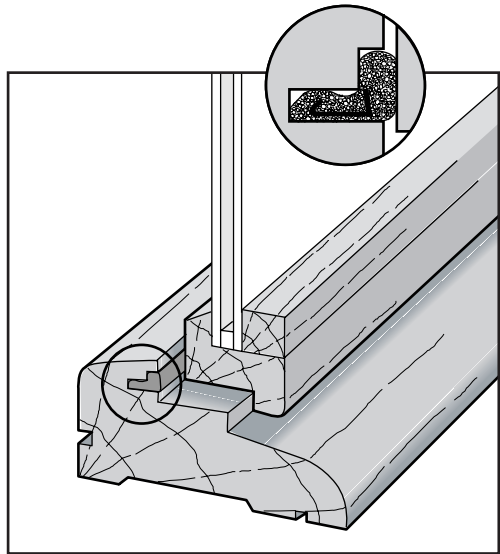

**A resilient non-stretch, non-shrink cellular core weatherseal with low friction outer sheath, to help prevent the binding of windows and doors.**

**trend**<sup>®</sup>  
routing technology

## Typical Application

Aquamac™ Weatherseal is fitted into the frame rebate aperture in four cut lengths. It is important to create tight butt or notch joints to ensure high levels of window performance. Joints can be enhanced by the application of a small amount of silicone mastic. When fitted it is necessary to notch the seal end.

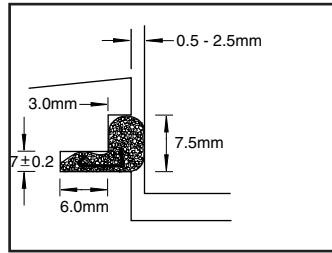
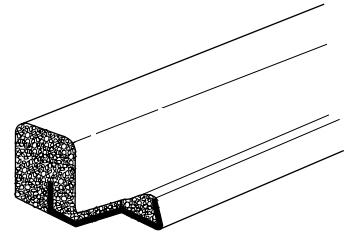
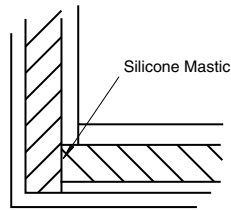
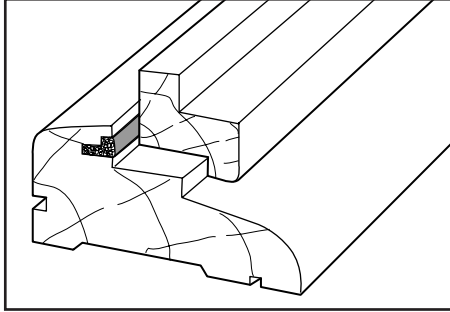

## TOOLING REQUIRED

The groove is routed in the frame using a 1/2" shank router and router cutter. The 330 set must be used with a side-fence, whereas the 331 set comes complete with a guide bearing to reduce setting-up time.

### AQUAMAC 63 RECESSER

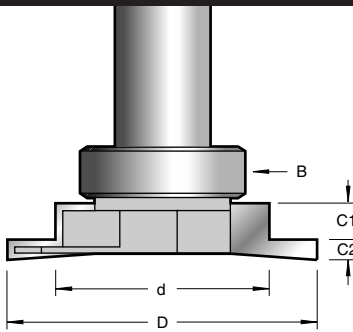

D mm	d mm	C1 mm	C2 mm	B mm	OL mm	Order Ref.
36	25	4.8	2.7	-	58	330x1/2TC
41.3	28.3	4.8	2.7	22	67	331x1/2TC
Spare bearing						B28

### Ref. HM/SHEAR

For perfect snipping and mitre cuts of weatherseal, mouldings and beading.



### Site Practice

AQUAMAC™ Weatherseals are unaffected by the application of paint and stain. Wet paint can be removed using a cloth moistened with a mild solvent i.e. white spirit.

### Maintenance

AQUAMAC™ Weatherseals can be wiped clean with a damp cloth. Normally a cleansing agent will not be required.

### References

AQUAMAC™ Weatherseals have been used throughout the world for many years and have proven to be successful in applications ranging from the arctic to tropical climates



### Trend Machinery & Cutting Tools Ltd.

Odhams Trading Estate St Albans Road Watford WD24 7TR

Tel: 0800 487363 Fax: 01923 236879

Email: enquiry@trendm.co.uk

WWW: www.trend-uk.com

Available from:

© All trademarks acknowledged  
© Trend Machinery & Cutting Tools Ltd 2007