

AQUAMAC™ 21 WEATHERSEAL

ENTRANCE DOOR FRAMES

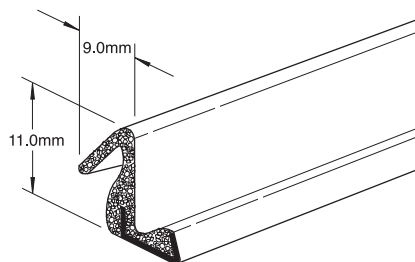

PERFORMANCE BENEFITS

- Returns to original shape after compression.
- Stretching and shrink back at corners avoided.
- Insert retention leg enables fast and effective insertion.
- Low compression force helps ease window and door operation.
- Maintains weathering characteristics and resists compression set over a wide temperature range +70°C to -30°C.
- Research has proved that Aquamac™ Weatherseal gives high levels of sound reduction.
- Unaffected by paint, stains, rot, fungi, UV light and ozone.
- Supplied in white or brown as standard.
- Suitable for all main timber window and door types.

Colour	Approximate Length	Order Ref.
White	10 metres	AQ21/W/10
White	25 metres	AQ21/W/25
White	250 metre roll	AQ21/W/250
Brown	10 metres	AQ21/B/10
Brown	25 metres	AQ21/B/25
Brown	250 metre roll	AQ21/B/250

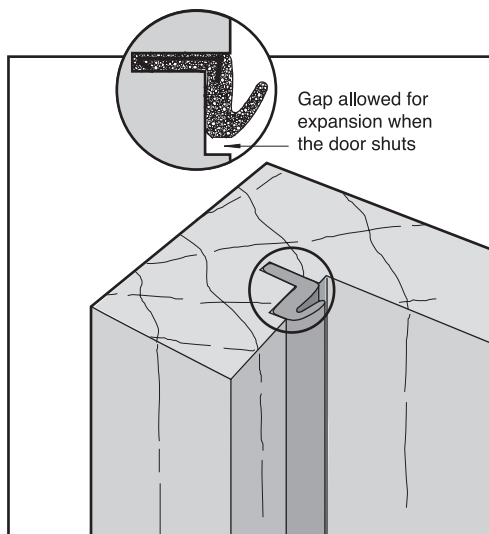

A resilient non-stretch, non-shrink cellular core weatherseal with low friction outer sheath, to help prevent the binding of windows and doors.



Typical Application

Aquamac™ Weatherseal is fitted into the frame rebate (head and jamps) as three cut lengths. Can be used to create a compression or wiping seal. The weatherseal is butt joined at the corners. To seal the door bottom a Weatherbar should be mounted into the threshold section.

It is important that AQUAMAC™ 21 Weatherseal does not abut the Weatherbar but runs to the threshold section in front (weatherside) of the Weatherbar, this will maximise water permeability resistance.

WIPING WEATHERSEAL

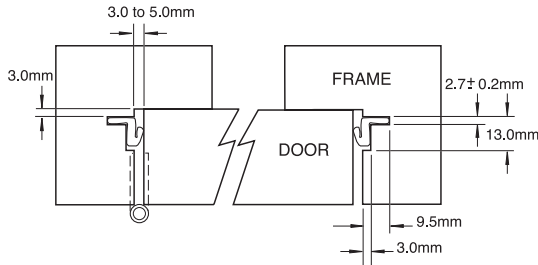

COMPRESSION WEATHERSEAL

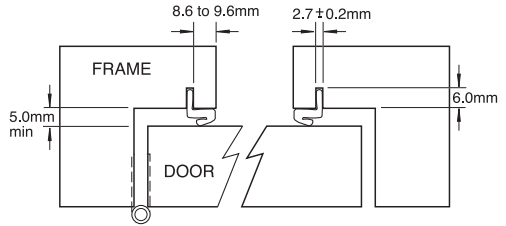

TOOLING REQUIRED

The groove is routed in the frame using a 1/2" shank capacity router and router cutter. Alternative bearing Ref. B35C is available for seals fitted in a compression mode of the seal. This larger bearing removes the rebate.

HM/SHEAR

For perfect snipping and mitre cuts of weatherseal, mouldings and beading.

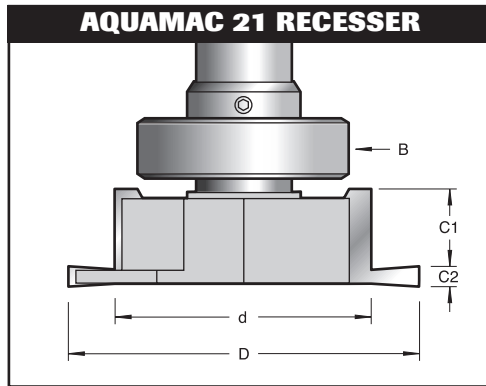
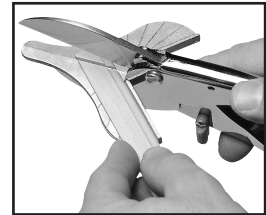

D mm	d mm	C1 mm	C2 mm	B mm	OL mm	Order Ref.
46.3	34.3	10.3	2.7	28.5	90	334X1/2TC
Spare bearing						B29C
Spare collar						COLL/12
Alternative bearing for compression mode						B35C

Site Practice

AQUAMAC™ Weatherseals are unaffected by the application of paint and stain. Wet paint can be removed using a cloth moistened with a mild solvent i.e. white spirit.

Maintenance

AQUAMAC™ Weatherseals can be wiped clean with a damp cloth. Normally a cleansing agent will not be required.

References

AQUAMAC™ Weatherseals have been used throughout the world for many years and have proven to be successful in applications ranging from the arctic to tropical climates



Trend Machinery & Cutting Tools Ltd.

Odhams Trading Estate St Albans Road Watford WD24 7TR

Tel: 0800 487363 Fax: 01923 236879

Email: enquiry@trendm.co.uk

WWW: www.trend-uk.com



Available from:

© All trademarks acknowledged
© Trend Machinery & Cutting Tools Ltd 2008