

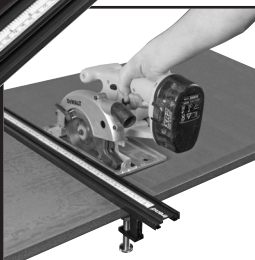

## Varijig System Guide 900mm VJS/G/35

Please  
read carefully  
before use



INST/VJS/G/35 v2.0

**trend**<sup>®</sup>  
routing technology

### VARIJIG SYSTEM GUIDE 35" (900mm) REF. VJS/G/35

Thank you for purchasing this Trend product which should give lasting performance if used in accordance with these instructions.

The following symbols are used throughout these instructions.



Denotes risk of personal injury, loss of life or damage to the tool in case of non-observance of the instructions.



Refer to the instruction manual of your power tool.

This unit must not be put into service until it has been established that the power tool to be connected to this unit is in compliance with 2006/42/EC (identified by the CE marking on the power tool).

#### INTENDED USE

This accessory is intended to be used with a portable circular saw, jigsaw or plunge router with suitable cutter fitted to cut man-made boards and natural timbers.

Working length:	2540mm (100")
Clamping thickness:	51mm
Weight:	2.3kg

#### SAFETY

Please read and understand the safety points at the end of this instruction as well as the power tool instructions before use.

PLEASE KEEP THESE INSTRUCTIONS IN A SAFE PLACE.

The attention of UK users is drawn to The Provision and Use of Work Equipment Regulations 1998, and any subsequent amendments.

Users should also read the HSE/HSC Safe Use of Woodworking Machinery Approved Code of Practice and Guidance Document and any amendments.

Users must be competent in using woodworking equipment before using our products.

Ensure all tooling used meets EN847 standard.

Residual risk: Every power tool involves a certain residual risk which cannot be excluded by safety mechanisms. Use power tools with caution.

#### ITEMS REQUIRED

- No. 2 Phillips<sup>®</sup> screwdriver.

#### ITEMS ENCLOSED & DESCRIPTION OF PARTS

- A. Extrusion 42" with scale **x1**
- B. Sliding clamp (extra long) **x2**
- C. Instructions **x1**

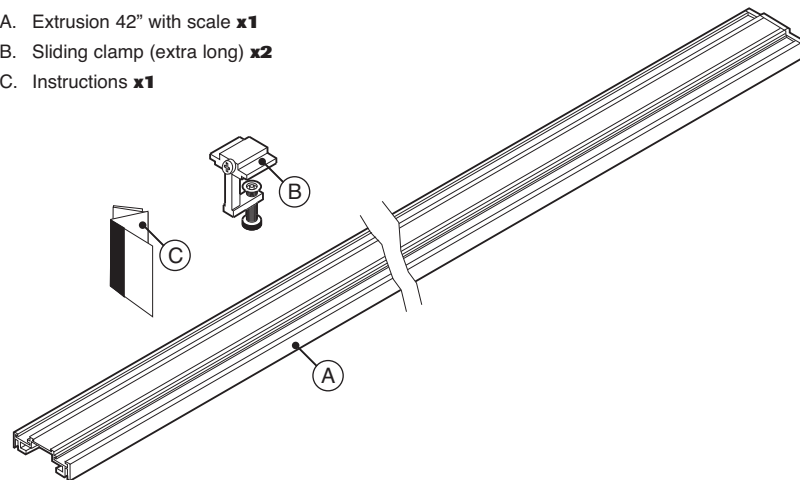

Please note the total length of the guide is 42" (1070mm). The extra length allows a full working length when using a circular saw.



The scale is self adhesive backed. Only remove a 20mm section of the self adhesive backing to ease positioning.

## ENVIRONMENTAL PROTECTION

Recycle raw materials instead of disposing as waste.

Packaging should be sorted for environmental-friendly recycling. The product and its accessories at the end of its life should be sorted for environmental-friendly recycling.

## GUARANTEE

All Trend products are guaranteed against any defects in either workmanship or material, except products that have been damaged due to improper use or maintenance.

© Trend Machinery & Cutting Tools Ltd. 2012 E&OE  
© All trademarks acknowledged

**Trend Machinery & Cutting Tools Ltd.**  
Odhams Trading Estate St. Albans Road  
Watford WD24 7TR England  
Tel: 0044(0)1923 249911  
technical@trendm.co.uk  
www.trend-uk.com



RECYCLABLE



RS 28982  
Stockholding  
& Supply



## ASSEMBLY



Ensure working position is comfortable, has good lighting and working area is clear.



Certain extrusions are fitted with end caps for protection. These can be temporarily removed to allow accessories to be slid onto the extrusion but should always be refitted.

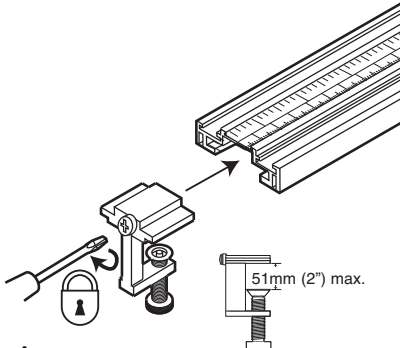

To prevent laminate breakout when cutting with a circular saw, the worktop should be placed laminate side down and the cut starting at the postformed edge. When cutting a breakfast bar worktop it is advisable to cut from either end.

## OPERATION



The clamps slide into the underside of the extrusion and clamp to workbench or component. To fit clamps the plastic end cap will need to be removed from the extrusions.

The clamps will not impede the router path and can clamp material up to a maximum of 51mm thickness. The clamp has a friction washer which can be adjusted with a screwdriver to adjust the free movement of the clamp in the extrusion.

To set the guide for a cut line marked on the material, measure the distance from the cutter edge to the base edge of the saw or router. This is the offset. Transfer this offset from the cut line and draw a new line. This new line is the position for the guide. Repeat for the other end of the guide.

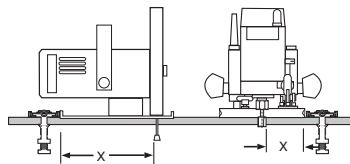

X= Offset distance required from edge of guide to edge of cutter of blade.



Ensure the guide is not clamped onto the waste piece. Ensure component is clamped properly.

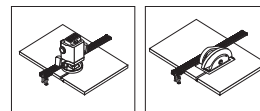

The material being cut will need to be supported and clamped securely. The guide can also be used to cut sheets at an angle.



The single scale, if necessary, can slide along the extrusion.

After use remove clamps and store carefully.

## ACCESSORIES

Please use only Trend original accessories. Other sizes of sliding friction clamps are available for the guide.

Ref. VJS/CK Clamping thickness 32mm.

Ref. VJS/PCK/L Pivot head clamp.  
Clamping thickness 51mm.

## MAINTENANCE

The accessory has been designed to operate over a long period of time with minimum of maintenance. Continual satisfactory operation depends upon proper tool care and regular cleaning. Only use Trend original spare parts.

## Cleaning

- Keep grooves on extrusion clear of sawdust.
- Regularly clean with a soft cloth.

## Lubrication

- Requires no additional lubrication.

## Storage

- Return to packaging after use.

## Safety Points

- Disconnect power tool and attachment from power supply when not in use, before servicing, when making adjustments and when changing accessories such as cutters. Ensure switch is in "off" position and cutter has stopped rotating.
- Read and understand instructions supplied with power tool, attachment and cutter.
- Current Personal Protective Equipment (PPE) for eye, ear and respiratory protection must be worn. Keep hands, hair and clothes clear of the cutter.
- Before each use check cutter is sharp and free from damage. Do not use if cutter is dull, broken or cracked or if any damage is noticeable or suspected.
- The maximum speed (nmax) marked on tool or in instructions or on packaging shall not be exceeded. Where stated, the speed range should be adhered to.
- Insert the shank into the router collet at least all the way to the marked line indicated on the shank. This ensures at least 3/4 of shank length is held in collet. Ensure clamping surfaces are clean.
- Check all fixing and fastening nuts, bolts and screws on power tool, attachment and cutting tools are correctly assembled, tight and to correct torque setting before use.
- Ensure all visors, guards and dust extraction is fitted.
- The direction of routing must always be opposite to the cutter's direction of rotation.
- Do not switch power tool on with the cutter touching the workpiece.
- Trial cuts should be made in waste material before starting any project.
- Repair of tools is only allowed according to tool manufacturers instructions.
- Do not take deep cuts in one pass, take shallow passes to reduce the side load applied to the cutter.

Please see [www.trend-uk.com/safety](http://www.trend-uk.com/safety) for more safety advice.

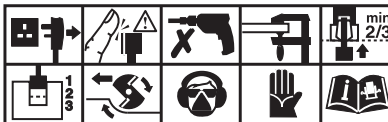

Our policy of continuous improvements mean that specifications may change without notice. Trend Machinery & Cutting Tools Ltd. cannot be held liable for any material rendered unusable, or for any form of consequential loss.