



TT/R127

Dear Customer

Thank you for purchasing this T-TECH product, we hope you enjoy many years of creative and productive use.

CONTENTS

TECHNICAL DATA _____ **1**

SAFETY _____ **2-3**

ELECTRICAL SAFETY _____ **4**

MANUFACTURERS DECLARATION _____ **5**

ITEMS ENCLOSED _____ **5**

DESCRIPTION OF PARTS _____ **6**

OPERATION _____ **7**

– Handle _____ **7**

– Speed Control _____ **7**

– Depth Gauge _____ **7**

– Depth Adjusting Knob _____ **7**

– On/Off Switch _____ **7**

– Plunge Lock Lever _____ **8**

– Depth Limiting Selector _____ **8**

– Parallel Side Fence Knob _____ **8**

– Depth Gauge Locking Knob _____ **8**

– Depth Limiting Steps _____ **8**

– Spindle Lock _____ **9**

– Lock-Off Button _____ **9**

– Base Plate _____ **9**

– Spindle _____ **9**

– Collet Nut _____ **9**

– Brush Cap Covers _____ **9**

– Parallel Side Fence _____ **10**

– Template Guide Bush _____ **10**

– Additional Collet _____ **11**

– Spanner _____ **11**

– Integrated Dust Extraction Tube _____ **11**

– Cutting Direction _____ **11**

– Feed Direction _____ **11**

– Feed Speed _____ **11**

– Moulding Natural Timbers _____ **11**

MAINTENANCE & CARE _____ **12**

ENVIRONMENTAL PROTECTION _____ **12**

GUARANTEE _____ **12**

TECHNICAL DATA

Voltage:	UK & Eire	240V
Power input		2050W
No load speed		15000-27,000 min-1
Router carriage		2 columns
Router carriage stroke		40mm with dust spout fitted. 60mm without dust spout fitted.
Revolver depth stop		turret stop adjustment with graduation
Collet size		6.35mm (1/4") 12.7mm (1/2")
Cutter diameter max.		45mm
Weight		6kg
Fuse:	UK & Eire	240V 13A in plug

The following symbols are used throughout this manual:



Denotes risk of personal injury, loss of life or damage to the tool in case of non-observance of the instructions in this manual.



Denotes risk of electric shock.



If you require further technical information, please call our Technical Hotline 01923 224681.

T-TECH™**SAFETY INSTRUCTIONS****WARNING!**

When using electric tools, basic safety precautions should always be followed to reduce the risk of fire, electric shock, and personal injury, including the following. Read all these instructions before attempting to operate this product and save these instructions for future use.

For safe operation please keep these instructions safe.

- **Keep work area clean**
Cluttered areas and benches invite injuries.
- **Consider work area environment**
Don't expose power tools to rain. Don't use power tools in damp or wet locations. Keep work area well lit. Do not use tool in presence of flammable liquids or gases.
- **Guard against electric shock**
Prevent body contact with grounded surfaces. For example: pipes, radiators, ranges and refrigerator enclosures. When using the machine outdoors or when moisture or dust could enter the machine, we recommend adding a residual current operated device (FI, RCD, PRCD), with a release current of max. 30mA.
- **Keep children and visitors away**
Do not let visitors contact tool or extension cord. All visitors should be kept away from work area.
- **Store idle tools**
When not in use, tools should be stored in a dry and high or locked-up place - out of reach of children.
- **Don't force tool**
It will do the job better and safer at the rate for which it was intended.
- **Use right tool**
Don't force small tool or attachment, to do the job of a heavy-duty tool. Don't use tool for purposes not intended. For example, don't use circular saw for cutting tree limbs or logs.
- **Dress properly**
Do not wear loose clothing or jewelry. They can be caught in moving parts. Rubber gloves and non-skid footwear is recommended when working outdoors. Wear protective hair covering to contain long hair.
- **Use safety glasses**
Also use face or dust mask if cutting operation is dusty.

- **Don't abuse cable**
Never carry tool by cord or yank it to disconnect from the socket. Keep cord from heat, oil and sharp edges.
- **Secure work**
Use clamps or a vice to hold work. It is safer than using your hand and it frees both hands to operate tool.
- **Don't over-reach**
Keep proper footing and balance at all times.
- **Use both handles**
If the tool is provided with two handles, use both hands for best control and safety.
- **Maintain tools with care**
Keep tools sharp and clean for better and safer performance. Follow instructions for lubricating and changing accessories. Inspect tool cords periodically and if damaged, have repaired by an authorised service facility. Inspect extension cords periodically and replace if damaged. Keep handles dry, clean and free from oil and grease.
- **Disconnect tools**
When not in use, before servicing, and when changing accessories, such as blades, bits and cutters etc.
- **Remove adjusting keys and spanners**
Form the habit of checking to see that keys and adjusting spanners are removed from tool before turning it on.
- **Avoid unintentional starting**
Don't carry plugged-in tool with your finger on switch. Be sure switch is off when plugging in.
- **Outdoor use extension cords**
When tool is used outdoors, use only extension cords intended for use outdoors and so marked.
- **Stay alert**
Watch what you are doing. Use common sense. Do not operate tool when you are tired.
- **Check damaged parts**
Before further use of the tool, a guard or other part that is damaged should be carefully checked to determine that it will operate properly and perform its intended function. Check for alignment of moving parts, binding or moving parts, breakage of parts, mounting and any other conditions that may affect its operation. A guard or other part that is damaged should be properly repaired or replaced by an Authorised Service Agent,

unless otherwise indicated elsewhere in this instruction manual. Have defective switches replaced by an Authorised Service Agent. Do not use tool if it cannot be turned on and off by the switch. If the tool has been dropped or otherwise subjected to high impact, damage may have occurred which is not always visible. For optimum safety, have the tool checked by an Authorised Service Agent before re-use.

- **Connect dust extraction equipment**
If devices are provided for the connection of dust extraction and collection facilities ensure these are connected and properly used.
- **Warning**
Use the tool accessories and tool bits etc, in accordance with these instructions and in the manner intended for the particular type of tool, taking into account the working conditions and the work to be performed. Use of the tool for operations different from that normally expected to be performed for the particular tool, could result in a hazardous situation.
- **Tool repairing by expert only**
This electric tool is in accordance with the relevant safety rules. Repairing of electric tools may be carried out only by experts, otherwise it may cause considerable danger for the user.

Routing Safety

- Personal Protective Equipment (PPE). All PPE must meet current UK and EU legislation.
- Do not leave tools running unattended. Do not leave tool until it comes to a complete stop.
- Always clamp workpiece being machined securely.
- Only use cutting tools for woodworking that meet EN847-1/2 safety standards, and any subsequent amendments.
- Disconnect router power tool. When not in use, before servicing and when changing accessories such as cutters, disconnect router and attachment from power supply.
- Ensure router cutter has stopped rotating before changing it. Never use the spindle lock as a brake.
- Remove adjusting keys and spanners. Form the habit of checking to see that keys and adjusting spanners are removed from the router tool, cutter and attachment before turning router on. Make sure cutter can rotate freely.



SAFETY INSTRUCTIONS

- Check all ball bearing and blade fixing screws before use to ensure they are tight and secure. Periodically check when machining over long periods.
- When using a template guide bush ensure it cannot come into contact with collet and nut.
- Noise. Take appropriate measures for the protection of hearing if the sound pressure of 85dB(A) is exceeded. Routing sound pressure may exceed 85dB(A), so ear protection must be worn.
- Eye protection. Wear safety goggles, spectacles or visors to protect the eyes from ejected waste particles.
- Respiratory protection. Wear a face or dust mask, or powered respirator. Dust masks/filters should be changed regularly.
- Do not switch router on with the cutter touching the workpiece.
- The direction of routing must always be opposite to the cutter's direction of rotation.
- After work, release the router plunge and allow spindle to stop rotating before putting machine down.
- Check before cutting that there are no obstructions in the path of the router. When cutting through the full thickness of the workpiece, ensure there are no obstacles beneath workpiece, and that a sacrificial work surface is used.
- Never use cutters with a diameter exceeding the maximum diameter indicated in the technical data of the powertool or attachment used.
- Do not drop cutters or knock them against hard objects. Do not use cutters that are damaged.
- Cutters should be kept clean. Resin build up should be removed at regular intervals. The use of a dry lubricant will act as a preventative. Do not use PTFE spray on plastic parts.
- Cutter shanks should be inserted into the collet to the mark line on the shank. This ensures that at least ¾ of the shank length is held in the collet. Do not over-tighten the collet nut as this will score the shank and create a weakness and fracture point.
- Observe the correct assembly instructions in the router instruction manual for fitting the collet and nut. Observe the router power tool manual instructions on fitting cutters correctly.
- It is advisable to periodically check the collet and collet nut. A worn, distorted or damaged collet can cause vibration and damage the shank, and should be replaced. Worn collet nuts should be replaced.
- Do not take deep cuts in one pass; take several shallow or light passes to reduce the side load applied to the cutter. Too deep a cut in one pass can stall the router.
- Very small diameter cutters must be handled and used with care.
- Ensure attachment is securely fitted to the workbench, with table surface at approximately hip height.
- Ensure a No-Volt Release Switch is fixed to or adjacent to the attachment and that it is used correctly.
- Check the direction of the workpiece is always opposite to the cutter's direction of rotation.
- Do not use awkward or uncomfortable hand positions.
- Do not reach underneath table or put your hands or fingers at any time in the cutting path while tool is connected to a power supply.

Useful Advice When Routing

- Judge your feed rate by the sound of the motor. Feed the router at a constant feed rate. Too slow a feed rate will result in burning.
- Take many light passes rather than one deep cut to reduce the side load applied to both router and router cutter.
- Trial cuts should be made on waste material before starting any project.
- When using some attachments including a router table or dovetail jig, the use of a fine height adjuster is highly recommended.
- When using a template guide bush, ensure there is sufficient clearance between cutter tip and inside edge of bush. Ensure cutter and guide bush are concentric.

Additional Safety Rules For Router Cutters

- Cutting tools are sharp. Care should be taken when handling them.
- Always use cutters with a shank diameter corresponding to the size of the collet installed in your tool.
- Always run router cutters at the spindle speed recommended and marked accordingly. Ensure cutter has reached correct speed before entering workpiece. Recommended speeds can be found on the packaging or cutter instructions.
- Always use router cutters in a router. Router cutters must not be used in a drill. Drill and boring bits must not be used in a router. Router cutters must only be used for the material cutting application for which they are designed. Do not use on metal or masonry.

Router Cutter Maintenance

- Always return cutter to its packaging after use.
- Should you experience excessive vibration during use stop immediately. Have the eccentricity of the router, router cutter and clamping system checked.
- All fastening screws and nuts should be tightened using the appropriate spanner or key in accordance with the manufacturers instructions.
- Composite cutting tools (brazed tip) must be maintained by a competent person i.e. a person of training and experience, who has knowledge of the design requirements and understands the levels of safety to be achieved.
- The design of composite tools must not be changed in the process of maintenance.
- Replacement parts must meet manufacturer's specification.

Using Routers In A Fixed Position

- After work, release the router plunge to protect the cutter.
- Always use a push-stick or push-block for last 300mm of the cut.
- Whenever possible use a work holding device or jig to secure component being machined.
- Tolerances which ensure correct clamping by the collet shall be maintained.
- When re-grinding the tool, care must be taken not to cause weakening of the body or the connection between the cutting edge and the body.

ELECTRICAL SAFETY



Power Supply

The electric motor has been designed for one voltage only. Always check that the power supply corresponds to the voltage on the rating plate. Machines marked for 230 volt can also be operated from a 220 volt supply.



The router is double insulated in accordance with EN 50144; therefore no earth wire is required.

Mains Plug Replacement (UK & Ireland only)

Always check the condition of the cable and plug before starting with your work.

Should your mains plug need replacing and you are competent to do this, proceed as instructed below. If you are in doubt, contact an authorised service agent or a qualified electrician.

- Disconnect the plug from the supply.
- Cut off the plug and dispose of it safely; a plug with bared copper conductors is dangerous if engaged in a live socket outlet.
- Only fit 13 Amperes BS 1363A approved plugs fitted with a 13 Amp BS 1362 fuse (1).
- The cable wire colours, or a letter, will be marked at the connection points of most good quality plugs. Attach the wires to their respective points in the plug (see below). Brown is for Live (L) (2) and Blue is for Neutral (N) (3).
- Before replacing the top cover of the mains plug ensure that the cable restraint (4) is holding the outer sheath of the cable firmly and that the two leads are correctly fixed at the terminal screws.

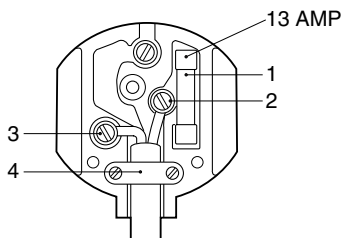

Never use a light socket. Never connect the live (L) or neutral (N) wires to the earth pin marked E or ⚡.

Using an Extension Cable

- If an extension cable is required, use an approved triple core extension cable suitable for the power input of this tool (see technical data).
- When using a cable reel, always unwind the cable completely.
- Also refer to the table below.

Cable Rating (Amperes)		
	Voltage 240V	
Cable Length (M)	7.5	6A
	15	6A
	25	6A
	30	6A
	45	10A
	60	15A

Conductor size (mm ²)	Cable rating (Amperes)
0.75	6
1.00	10
1.50	15
2.50	20
4.00	25

T-TECH™**TT/R127****MANUFACTURERS
DECLARATION****CE TT/R127**

We declare under our sole responsibility that this product is in conformity with the following standards of standardised documents:

EN 50144.1, EN 50144.2.17, EN 55014.1, EN 55014.2, EN 61000.3.2, EN 61000.3.3 in accordance with the directives 98/37/EC, 73/23/EEC, 93/68/EEC, 89/336/EEC.

Level of sound pressure according to 86/188/EEC & 98/37/EC, measured according to EN 50144:

Lpa (sound pressure) 93 dB(A)1

Lwa (acoustic power) 106 dB(A)2

**INFORMATION ON
NOISE/VIBRATION**

The noise level when working can exceed 85 dB(A).

Wear ear protection!

Weighted root mean square acceleration value according to EN 50144:

>2.06 m/s²

Performance Power Tools
www.performancepowertools.com

ITEMS ENCLOSED

- 1 x Parallel side-fence
- 2 x Side-fence rods
- 1 x Collet 6.35mm (1/4")
- 1 x Collet 12.7mm (1/2") fitted to machine
- 1 x Guide bush 30mm, guide bush plate and screws
- 1 x Spanner (25mm A/F) for spindle
- 1 x Hex key (4mm A/F) for side-fence
- 1 x Dust extractor spout adapter
- 1 x Instructions

T-TECH™

TT/R127

DESCRIPTION OF PARTS

- | | |
|-----------------------------|-----------------------------------|
| ① Handle (x2) | ⑫ Lock-off button |
| ② Speed control | ⑬ Base plate |
| ③ Depth gauge | ⑭ Spindle |
| ④ Depth adjusting knob | ⑮ Collet nut |
| ⑤ On/Off switch | ⑯ Brush cap (x2) |
| ⑥ Plunge lock lever | ⑰ Parallel side fence |
| ⑦ Depth limiting selector | ⑱ Template guide bush |
| ⑧ Parallel side fence knobs | ⑲ Additional collet (6.35mm) |
| ⑨ Depth gauge locking knob | ⑳ Spanner |
| ⑩ Depth limiting steps | ㉑ Integrated dust extraction tube |
| ⑪ Spindle lock | ㉒ Collet assembly |

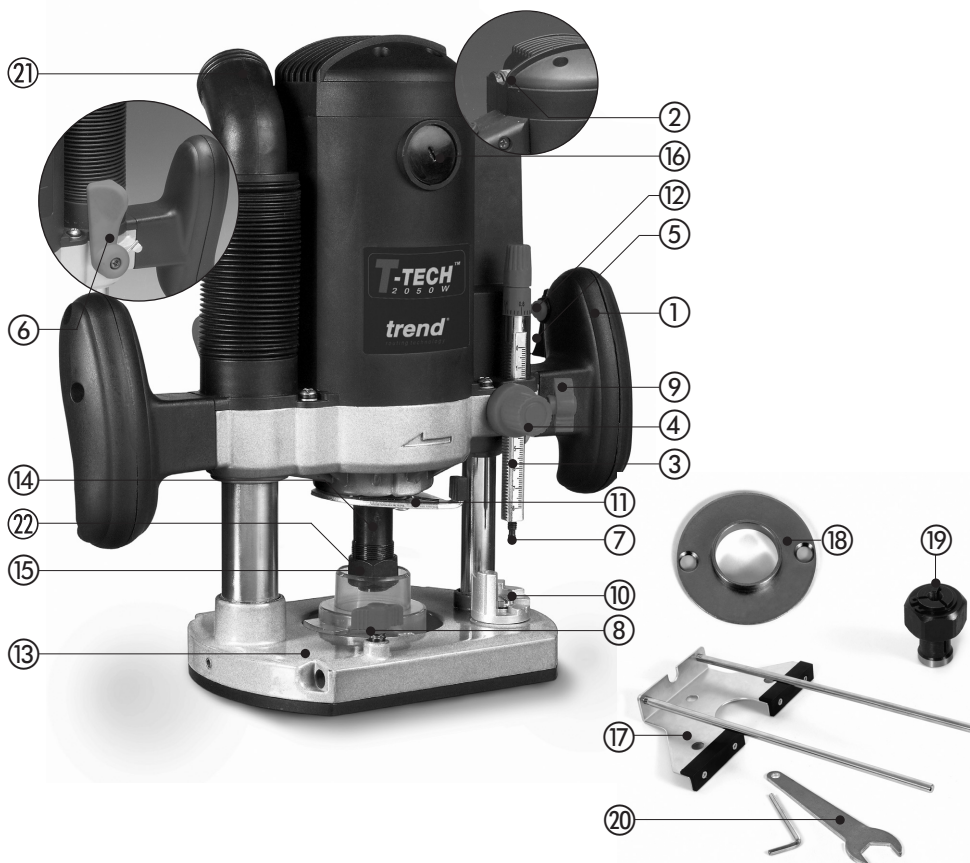

T-TECH™

TT/R127

OPERATION



1. Handle

Always use both handles (1) and make sure that you have a firm grip on the router before proceeding with any work.

2. Speed Control

Adjust the speed control (2) to suit different working materials. The tool cuts quicker and smoother at different speeds when working in different woods or in plastic or aluminium.

Determine the optimum speed by making a trial cut in a scrap piece of material.



3. Depth Gauge

The depth gauge (3) is used when setting the depth of cut. It has a scale with graduations in millimetres with a micrometer adjustment knob on top. One complete turn of the micrometer knob moves the depth gauge a distance of 1mm.

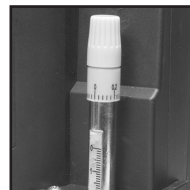

4. Depth Adjusting Knob

The depth adjusting knob (4) moves the depth gauge (3) up and down.



Using the correct speed for the job increases the life of the cutter.

Dial No.	Router Speed
A	8,000 rpm
B	12,000 rpm
C	16,000 rpm
D	20,500 rpm
E	24,000 rpm
F	28,000 rpm
G	32,000 rpm



These speeds are approximate values (within 20%) and are for reference purpose only.

5. On/Off Switch

The on/off switch (5) is located on the handle (1). It can be operated only when the lock-off button (12) is depressed.

- To switch on, press on the lock-off button (12) and depress the trigger switch (5). Continue to press the switch (5) throughout the whole cutting operation. You do not need to hold the lock-off button (12) depressed. As long as you keep the on/off switch (5) depressed, the tool will remain on.



- To switch off, just release pressure on the switch (5).

6. Plunge Lock Lever 

In its normal position, the lever (6) prevents the router body and hence the router cutter, from moving up and down. The lock is released by moving the lever to the right against the pressure of the spring which returns the lever to the locked position once pressure is removed.



- Release the plunge lock lever.
- Adjust the knob (4) until the depth gauge (3) just touches a depth limiting step on the depth limiting selector (7).
- Raise the depth gauge (3) using the knob (4) and the micrometer adjustment if necessary. The distance raised will be the depth of cut when using that depth limiting step.
- Tighten the depth gauge locking knob (9).
- You can rotate the depth limiting selector (7) to set the depth of cut at a different value. This procedure is particularly useful when you wish to make a deep cut in a number of stages.

Sequence of plunging 

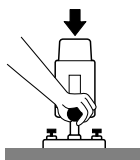

Step One

Plunge down and lock the motor carriage, with the plunge locking lever.

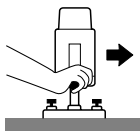

Step Two

Carry out the routing operation.

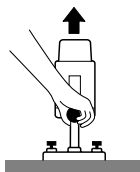

Step Three

Release the plunge locking lever and the motor carriage returns to the normal position.

8. Parallel Side Fence Knob 

The parallel side fence locking knobs (8) located on the base plate (13) hold the parallel side fence (17) in position.

9. Depth Gauge Locking Knob 

The knob (9) secures the depth gauge (3) in position.



Take care not to try and adjust the position of the depth gauge (3) when it is secured by the locking knob. You could damage the screw mechanism.

7. Depth Limiting Selector 

The depth limiting selector (7) provides a convenient and fast means of setting the depth of cut to eight different levels as follows:

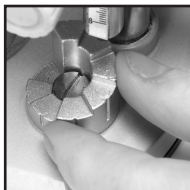

- Loosen the depth gauge locking knob (9) and turn the depth adjusting knob (4) to raise the depth gauge (3) to its highest position.
- Place the router on a flat surface, use your thumb to hold the plunge lock lever (7) to the right and push the router body down until the cutter just touches the flat surface.

10. Depth Limiting Steps 

There are eight steps on the depth limiting selector (7). By rotating the selector so that a different step is directly under the depth gauge (3), it is possible to quickly and easily set the depth of cut at eight different values.



T-TECH™**TT/R127****11. Spindle Lock**

Always ensure that the tool is switched off and the plug is removed from the power point before making any adjustments or maintenance procedures. Always wear sturdy gloves when handling or changing cutters as they can be very sharp.

The spindle lock (11) is a lever that locks the spindle allowing easy cutter changes as outlined below:

Ensure that the correct collet assembly (22) is installed for the cutter you are about to fit. Cutters with a 12.7mm shank fit into the 12.7mm collet and cutters with a 6.35mm shank fit into the 6.35mm collet.

- To remove a collet, first release the plunge lock lever (6) and ensure that the router body is in its highest position.
- Push the spindle lock lever (11) to the left to lock the spindle and using the spanner (20) provided, undo the collet nut (15).
- Remove the collet assembly (22) from underneath the dust shroud.
- Insert the new collet assembly into the spindle. This is sometimes easier if the router is plunged to its full depth.
- Tighten the collet nut (15) but do not over tighten. Insert the shank of the cutter all the way into the collet and tighten the collet nut (15) with the wrench (20).

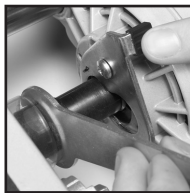

Do not fully tighten the collet nut with the spanner unless there is a cutter in place or you may damage the collet.



Make sure that the cutter is firmly secured before commencing operation.

12. Lock-Off Button

The lock-off button (12) provides a safety measure to prevent the router from being accidentally switched on.

- The on/off trigger switch (5) can only be depressed when the lock-off button is also depressed.
- When the switch (5) is released the lock-off button is automatically re-engaged preventing inadvertent operation of the router.

**13. Base Plate**

The base plate (13) has additional drilled and tapped holes to allow the attachment of various templates and accessories.

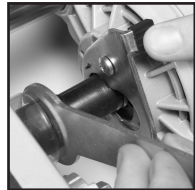
**14. Spindle**

The spindle (14) has an external thread which accepts the collet nut (15).

15. Collet Nut

The collet nut (15) attaches the collet assembly (22) to the spindle. The router cutter is held secure by tightening the collet nut.

16. Brush Cover Caps

To gain access to the carbon brush and spring sets, unscrew the two brush cap covers (16).

17. Parallel Side Fence 

The parallel side fence (17) is an effective aid to cutting in a straight line when chamfering or grooving.

- Feed the guide rods through the holes in the router base on the right side of the router in the feed direction. This will help you to keep the guide flush with the side of the work piece.



- Adjust the distance between the cutter and the parallel side fence (17) by moving the guide.
- Tighten the knobs (8) to hold the guide in the correct position.

If the distance between the side of the workpiece and the cutting position is too wide, or the side of the work piece is not straight, firmly clamp a straight board to the work piece and use this as a guide against the router base.

18. Template Guide Bush 

The template guide (18) can be used in various ways:

- Producing duplicates of a particular design of an original shape.
- In conjunction with a template, producing decorative features.
- Repetitive cutting shapes.

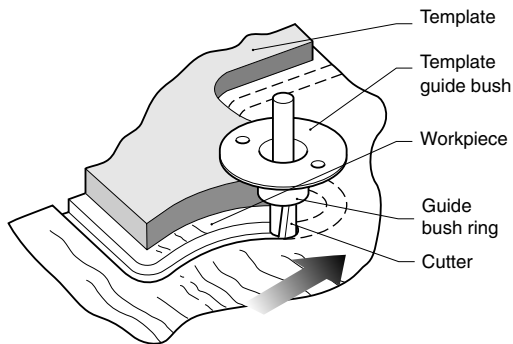

If you wish to make your own templates it is best to use a hardwood such as plywood. Use a piece that is just thicker than the depth of the template guide. Allow for the thickness of the guide in your template to ensure that the work piece is cut to the correct size.

A cutter is chosen with a diameter which will pass through the centre of the bush leaving enough clearance. The cutter can be straight or shaped. The router can then be guided around the template so that the shape of the template will be replicated.

The guide bush offset needs to be allowed for when calculating the shape of the template. The template must be smaller by an amount equal to the difference between the 'outer edge of the guide ring' and the 'outer edge of the cutter'. See below for the offset calculation. The edge of the template must be free of imperfections as these will be replicated in the final workpiece.

Calculations for template offset

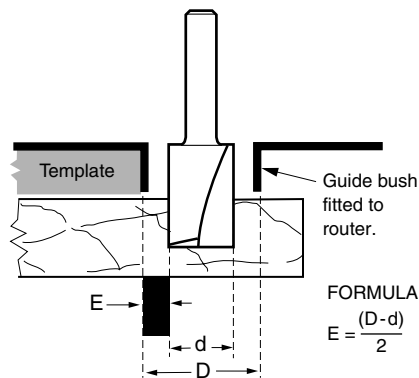

T-TECH™

TT/R127

19. Additional Collet

Two collet assemblies are provided with the router: a 12.7mm (1/2") and a 6.35mm (1/4"). At purchase, the 12.7mm collet is fitted to the router.



20. Spanner

The supplied spanner (20) is used to tighten the collet nut (15).



Do not fully tighten the collet nut with the spanner unless there is a cutter in place or you may damage the collet.

21. Integrated Dust Extraction Tube

The integrated dust extraction tube (21) allows a dust extraction system to be fitted to the router permitting the efficient removal of dust whilst the router is in use.



Do not use a dust extraction system or a vacuum cleaner when working on metal surfaces. Sparks may ignite residual wood dust.

Cutting Direction

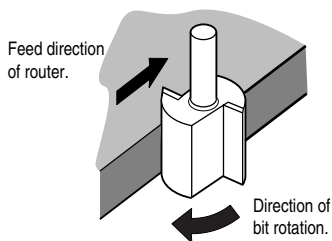

The direction of routing must always be opposite to the cutter's direction of rotation, otherwise there is a risk of kick-back.

Feed Direction

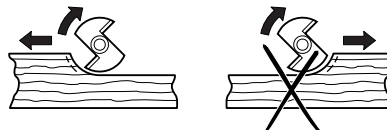

When routing along an edge, the direction of the router travel should be against that of the rotation of the cutter. This will create the correct cutting action and prevent the cutter 'snatching'. It will also pull the router towards the workpiece and hence the side-fence or guide bearing will be less likely to wander from the edge of the workpiece.

Feed Speed

The speed at which the cutter is fed into the wood must not be too fast that the motor slows down, or too slow that the cutter leaves burn marks on the face of the wood. Practice judging the speed by listening to the sound of the motor when routing.

Moulding Natural Timbers

When edge moulding natural timbers, always mould the end grain first, followed by the long grain. This ensures that if there is 'breakout', this will be removed when the long grain is routed.

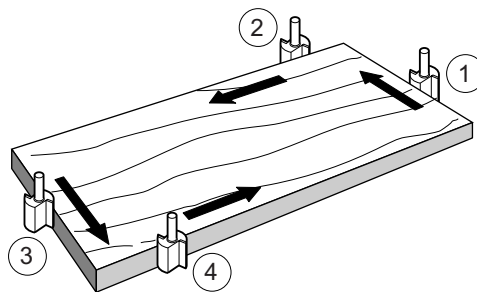

T-TECH™**TT/R127**

MAINTENANCE AND CARE

Cleaning

- Keep the machine clean at all times. Wipe the outside clean with a dry cloth. Some maintenance products and solvents may damage the plastic parts, these include products containing Benzene, Trichloroethylene Chloride and Ammonia.
- Never use water to clean your power tool.
- Never use any caustic agents to clean the plastic parts.

Changing Brushes



Ensure machine is isolated from power supply.

Regularly check that the carbon brushes are not over worn and replace if necessary.

Proceed as follows:

- Unscrew the carbon brush caps (16) located either side of the body of the motor housing.
- Replace the two brush and spring sets, taking care to maintain the same positioning.
- Replace the brush caps.

Lubrication

- The bearings of the machine need no lubrication, as they are sealed. The two plunge columns on the routing base should be slightly oiled from time to time.
- Keep the cooling vents on the motor housing clean and unobstructed at all times. Use a soft brush or blow out any dust and dirt at regular intervals. Wear safety glasses to protect eyes whilst cleaning.
- Visually check the carbon brushes. In the event of excessive sparking, they may need changing.

ENVIRONMENTAL PROTECTION

Accessories and packaging should be sorted for environmental-friendly recycling.



Separate collection. This must not be disposed of with normal household waste.

Waste electrical products should not be disposed of with normal household waste. Please recycle where facilities exist. Check with your Local Authority or retailer for recycling advice.

GUARANTEE

This product has been made to demanding, high quality standards and is guaranteed for domestic use against manufacturing faults for a period of 12 months from the date of purchase.

This guarantee does not affect your statutory rights. If your product fails due to a defect in material or workmanship during this period, please return it to your nearest B&Q store.

Normal wear and tear, including accessory wear, is not covered under guarantee. The product is guaranteed for 12 months if used for normal trade purposes. Any guarantee is invalid if the product has been overloaded or subject to neglect, improper use or an attempted repair other than by an authorised agent. Heavy duty, daily professional or hire usage are not guaranteed. Due to continuous product improvement, we reserve the right to change the product specification without prior notice.





MANU/TT/R127 v2.0



For technical information only contact:

Trend Machinery & Cutting Tools Ltd.

Technical Hotline: _____ 01923 224681

Email: _____ technical@trendm.co.uk

Web: _____ www.trendmachinery.co.uk

© Copyright 2005. No part of this publication may be reproduced, stored or transmitted in any form without prior permission. Our policy of continuous improvement means that specifications may change without notice. Trend Machinery and Cutting Tools and B&Q Plc cannot be held liable for any material rendered unusable or any form of consequential loss. E&OE

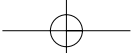
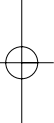
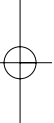



12.7mm (HALF INCH)
2050W ROUTER
TT/R127



trend[®]
routing technology

WARNING 
Read the instructions
before operating the tool.