



T5_{MK1} V2 & T5_{MK2} V2



V2 Released May 2009

trend[®]
routing technology



Please read these instructions before use.

Dear Customer

Thank you for purchasing this Trend product, we hope you enjoy many years of creative and productive use.

Please remember to return your guarantee card within 28 days of purchase.

CONTENTS

TECHNICAL DATA _____	1
SAFETY _____	2-3
ELECTRICAL SAFETY _____	4
EC DECLARATION OF CONFORMITY _____	5
ITEMS ENCLOSED _____	5
DESCRIPTION OF PARTS _____	6
ASSEMBLY & ADJUSTMENT	
– Dust Extractor Spout _____	7
– Handle Direction Arrow _____	7
– Switching On & Off _____	8
– Depth of Cut _____	8
– Fitting & Removing Cutters _____	9
– Speed Control _____	10
– Fine Height Adjuster _____	10
– Fixing Points _____	10
OPERATION	
– Cutting Direction & Feed Speed _____	11
– Side-fence Routing _____	12
– Template Guide Bush Routing _____	13
– Beam Trammel Routing _____	14
– Bearing Guided Cutters _____	15
– Freehand Routing & Batten Routing _____	16
MAINTENANCE & CARE _____	17
ENVIRONMENTAL PROTECTION _____	17
GUARANTEE _____	17
SPARE PARTS	
– Spare Parts List _____	18-19
– Spare Parts Diagram _____	20

TECHNICAL DATA

Voltage:	UK & Eire	240V
	UK & Eire only	115V
	Europe	230V
Ampage:	240V	4.6A
	115V	9.5A
Power input		1010W
Power output		600W
No load speed (min.)		9,000-27,000 rpm
Router carriage		2 columns
Router carriage stroke		50mm
Revolver depth stop		3-step, turret stop adjustment with graduation
Collet size:	UK & Eire	1/4 inch (6.35mm)
	Europe	8mm
Cutter diameter, max.		40mm
Weight		3.2kg
Fuse:	UK & Eire	240V 13A in plug
	UK & Eire	110V 16A in mains
	Europe	230V 10A in mains

The following symbols are used throughout this manual:



Denotes risk of personal injury, loss of life or damage to the tool in case of non-observance of the instructions in this manual.



Denotes risk of electric shock.

INTENDED USE

The router is intended for routing grooves, edges, profiles and slots as well as copy routing in wood, wood based products and plastic. At reduced speed with the appropriate router cutter fitted non-ferrous alloys can also be routed.



If you require further safety advice, technical information or spare parts, please call Trend Technical Support or visit www.trend-uk.com

SAFETY



WARNING:

Observe the safety regulations in the instruction manual of the power tool to be used. Please read the following instructions carefully. Failure to do so could lead to serious injury. When using electric tools, basic safety precautions, including the following should always be followed to reduce the risk of fire, electric shock and personal injury. Also observe any applicable additional safety rules. Read the following safety instructions before attempting to operate this product.

PLEASE KEEP THESE INSTRUCTIONS IN A SAFE PLACE.

The attention of UK users is drawn to The Provision and Use of Work Equipment Regulations 1998, and any subsequent amendments.

Users should also read the HSE/HSC Safe Use of Woodworking Machinery Approved Code of Practice and Guidance Document and any amendments.

Users must be competent with woodworking equipment before using our products.

IMPORTANT NOTE:

Residual Risk. Although the safety instructions and operating manuals for our tools contain extensive instructions on safe working with power tools, every power tool involves a certain residual risk which cannot be completely excluded by safety mechanisms. Power tools must therefore always be operated with caution!

General

1. Disconnect power tool and attachment from power supply when not in use, before servicing, when making adjustments and when changing accessories such as cutters. Ensure switch is in "off" position. Always ensure cutter has stopped rotating.
2. Always mount the power tool, accessory or attachment in conformity with the instructions. Only use attachment and accessories specified in the power tool manual. The tool or attachment should not be modified or used for any application other than that for which it was designed. Do not force tool.
3. Keep children and visitors away. Do not let children or visitors touch the tool, accessory or attachment. Keep children and visitors away from work area. Make the workshop child proof with padlock and master switch.
4. Dress properly. Do not wear loose clothing or jewellery, they can be caught in moving parts. Rubber gloves and non-skid footwear is recommended when working

outdoors. Wear protective hair covering to contain long hair.

5. Consider working environment. Do not use the product in the rain or in a damp environment. Keep work area well lit. Do not use power tools near gasoline or flammable liquids. Keep workshop at a comfortable temperature so your hands are not cold. Connect machines that are used in the open via a residual current device (RCD) with an actuation current of 30 mA maximum. Use only extension cables that are approved for outdoor use.
6. The accessory or attachment must be kept level and stable at all times.
7. Keep work area clean. Cluttered workshops and benches can cause injuries. Ensure there is sufficient room to work safely.
8. Secure idle tools. When not in use, tools should be stored in a dry and high or locked up place, out of reach of children.
9. For best control and safety use both hands on the power tool and attachment. Keep both hands away from cutting area. Always wait for the spindle and cutter to stop rotating before making any adjustments.
10. Always keep guards in place and in good working order.
11. Remove any nails, staples and other metal parts from the workpiece.
12. Maintain tools and cutters with care. Keep cutters sharp and clean for better and safer performance. Do not use damaged cutters. Follow instructions for lubricating and changing accessories. Keep handles dry, clean and free from oil and grease.
13. Maintain accessories. Do not use damaged accessories. Only use accessories recommended by the manufacturer.
14. Check damaged parts. Before operation inspect the attachment, the power tool, the cable, extension cable and the plug carefully for signs of damage. Check for alignment of moving parts, binding, breakage, mounting and any other conditions that may effect its operation. Have any damage repaired by an Authorised Service Agent before using the tool or accessory. Protect tools from impact and shock.
15. Do not use tool if switch does not turn it on or off. Have defective switches replaced by an Authorised Service Agent
16. Don't over reach. Keep proper footing and balance at all times. Do not use

awkward or uncomfortable hand positions.

17. Don't abuse the cable. Never carry power tool or accessory by cord or pull it to disconnect from the socket. Keep cord from heat, oil and sharp edges. Always trail the power cord away from the work area.
18. Connect dust extraction equipment. If devices are provided for the connection of dust extraction and collection facilities, ensure these are connected and properly used.
19. Check all fixing and fastening nuts, bolts and screws on power tool, attachment and cutting tools before use to ensure they are tight and secure. Periodically check when machining over long periods.
20. Stay alert. Watch what you are doing. Use common sense. Do not operate tools when you are tired, under the influence of drugs or alcohol.
21. Personal Protective Equipment (PPE) for eye, ear and respiratory protection must be worn. All PPE must meet current UK and EU legislation.
22. Do not leave tools running unattended. Do not leave tool until it comes to a complete stop.
23. Always clamp workpiece being machined securely.
24. Only use cutting tools for woodworking that meet EN847-1/2 safety standards, and any subsequent amendments.
25. Vibration levels. Hand held power tools produce different vibration levels. You should always refer to the specifications and relevant Health & Safety Guide.

Routing Safety

1. Read and understand instructions supplied with power tool, attachment and cutter.
2. Keep hands, hair and clothing clear of the cutter.
3. Remove adjusting keys and spanners. Check to see that keys and adjusting spanners are removed from the router tool, cutter and attachment before turning router on. Make sure cutter can rotate freely.
4. Noise. Take appropriate measures for the protection of hearing if the sound pressure of 85dB(A) is exceeded. Routing sound pressure may exceed 85dB(A), so ear protection must be worn.
5. Eye protection. Always wear eye protection in the form of safety goggles, spectacles or visors to protect the eyes.

6. Respiratory protection. Wear a face or dust mask, or powered respirator. Dust masks/filters should be changed regularly.
7. Do not switch router on with the cutter touching the workpiece. At the end of the cut, release the router plunge and allow spindle to stop rotating. Never use the spindle lock as a brake
8. The direction of routing must always be opposite to the cutter's direction of rotation. Do not back-cut or climb-cut.

9. Check before cutting that there are no obstructions in the path of the router. Ensure there are no obstacles beneath workpiece when cutting full thickness, and that a sacrificial work surface is used.

Router Cutter Safety

1. Cutting tools are sharp. Care should be taken when handling them. Do not drop cutters or knock them against hard objects. Handle very small diameter cutters with extra care. Always return cutter to its packaging after use.
2. Always use cutters with a shank diameter corresponding to the size of the collet installed in your tool.
3. The maximum speed (n.max) marked on the tool, or in instructions or on packaging shall not be exceeded. Where stated the speed range shall be adhered to. Recommended speeds are shown in the Trend Routing Catalogue and/or website.
4. Always use router cutters in a router. Drill and boring bits must not be used in a router. Router cutters must only be used for the material cutting application for which they are designed. Do not use on metal or masonry.
5. Never use cutters with a diameter exceeding the maximum diameter indicated in the technical data of the powertool or attachment used.
6. Before each use check that the cutting tool is sharp and free from damage. Do not use the cutting tool if it is dull, broken or cracked or if in any other damage is noticeable or suspected.
7. Cutters should be kept clean. Resin build up should be removed at regular intervals with Resin Cleaner. The use of a PTFE dry lubricant will reduce resin build up. Do not use PTFE spray on plastic parts.
8. When using stacked tooling (multi-blade, block and groover etc.) on a spindle arbor, ensure that the cutting edges are staggered to each other to reduce the cutting impact.
9. Cutter shanks should be inserted

into the collet all the way to the line indicated on the shank. This ensures that at least $\frac{3}{4}$ of the shank length is held in the collet. Ensure clamping surfaces are cleaned to remove dirt, grease, oil and water.

10. Observe the correct assembly and fitting instructions in the router instruction manual for fitting the collet, nut and cutter.
11. Tool and tool bodies shall be clamped in such a way that they will not become loose during operation. Care shall be taken when mounting cutting tools to ensure that the clamping is by the shank of the cutting tool and that the cutting edges are not in contact with each other or with the clamping elements.
12. It is advisable to periodically check the collet and collet nut. A damaged, worn or distorted collet and nut can cause vibration and shank damage. Do not over-tighten the collet nut
13. Do not take deep cuts in one pass; take several shallow or light passes to reduce the side load applied to the cutter and router. Too deep a cut in one pass can stall the router.
14. In case of excessive vibrations whilst using the router stop immediately and have the eccentricity of the router, router cutter and clamping system checked by competent personnel
15. All fastening screws and nuts should be tightened using the appropriate spanner or key and to the torque value provided by the manufacturer.
16. Extension of the spanner or tightening using hammer blows shall not be permitted.
17. Clamping screws shall be tightened according to instructions provided by the manufacture. Where instructions are not provided, clamping screws shall be tightened in sequence from the centre outwards.

Using Routers In A Fixed Position

1. Attention should be made to the HSE's Safe Use of Vertical Spindle Moulding Machines Information Sheet No.18 and any revisions.
2. After work, release the router plunge to protect the cutter.
3. Always use a push-stick or push-block when making any cut less than 300mm in length or when feeding the last 300mm of the cut.
4. The opening around the cutter should be reduced to a minimum using suitably sized insert rings in the table and closing the back fence cheeks or fitting a false fence on the back fence.
5. Whenever possible use a work

holding device or jig to secure component being machined. Ensure any attachment is securely fitted to the workbench, with table surface at approximately hip height.

6. Use a No-Volt Release Switch. Ensure it is fixed securely, easily accessible and used correctly.
7. In router table (inverted) mode, stand to the front right of the table. The cutter will rotate anti-clockwise when viewed from top so the feed direction is from the right (against the rotation of the cutter). In overhead mode, stand to the front left of the machine table and the feed direction is from the left.
8. Do not reach underneath table or put your hands or fingers at any time in the cutting path while tool is connected to a power supply.
9. Never thickness timber between the back of the cutter and the backfence.

Useful Advice When Routing

1. Judge your feed rate by the sound of the motor. Feed the router at a constant feed rate. Too slow a feed rate will result in burning.
2. Trial cuts should be made on waste material before starting any project.
3. When using some attachments e.g. a router table or dovetail jig, a fine height adjuster is recommended.
4. When using a template guide bush, ensure there is sufficient clearance between cutter tip and inside edge of bush and that it cannot come into contact with collet and nut. Ensure cutter and guide bush are concentric.

Router Cutter Repair/Maintenance

1. Repair of tools is only allowed in accordance with the manufacturers instructions.
2. The design of composite (tipped) tools shall not be changed in process of repair. Composite tools shall be repaired by a competent person i.e. a person of training and experience, who has knowledge of the design requirements and understands the levels of safety to be achieved.
3. Repair shall therefore include, e.g. the use of spare parts which are in accordance with the specification of the original parts provided by the manufacturer.
4. Tolerances which ensure correct clamping shall be maintained.
5. Care shall be taken that regrinding of the cutting edge will not cause weakening of the body and the connection of the cutting edge to the body.

ELECTRICAL SAFETY



Power Supply

The electric motor has been designed for one voltage only. Always check that the power supply corresponds to the voltage on the rating plate. Machines marked for 230 volt can also be operated from a 220 volt supply.



The T5 is double insulated in accordance with EN 50144; therefore no earth wire is required.

Mains Plug Replacement (UK & Ireland only)

Always check the condition of the cable and plug before starting with your work.

Should your mains plug need replacing and you are competent to do this, proceed as instructed below. If you are in doubt, contact an authorised Trend repair agent or a qualified electrician.

- Disconnect the plug from the supply.
- Cut off the plug and dispose of it safely; a plug with bared copper conductors is dangerous if engaged in a live socket outlet.
- Only fit 13 Amperes BS 1363A approved plugs fitted with a 13 Amp A.S.T.A approved BS 1362 fuse (1).
- The cable wire colours, or a letter, will be marked at the connection points of most good quality plugs. Attach the wires to their respective points in the plug (see below). Brown is for Live (L) (2) and Blue is for Neutral (N) (3).
- Before replacing the top cover of the mains plug ensure that the cable restraint (4) is holding the outer sheath of the cable firmly and that the two leads are correctly fixed at the terminal screws.

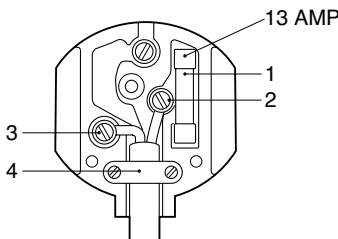

For 115V units with a power rating exceeding 1500W we recommend to use a plug to BS4343 standard.



Never connect to a light socket. Never connect the live (L) or neutral (N) wires to the earth pin marked E or ⚡.

Using an Extension Cable

- If an extension cable is required, use an approved triple core extension cable suitable for the power input of this tool (see technical data).
- When using a cable reel, always unwind the cable completely.
- Also refer to the table below.

Conductor size (mm ²)	Cable rating (Amperes)
0.75	6
1.00	10
1.50	15
2.50	20
4.00	25

Voltage	Amperes	Cable length (m)					
		7.5	15	25	30	45	60
115	0 - 2.0	6	6	6	6	6	10
	2.1 - 3.4	6	6	6	6	15	15
	3.5 - 5.0	6	6	10	15	20	20
	5.1 - 7.0	10	10	15	20	25	25
	7.1 - 12.0	15	15	20	25	25	-
	12.1 - 20.0	20	20	25	-	-	-
230	0 - 2.0	6	6	6	6	6	6
	2.1 - 3.4	6	6	6	6	6	6
	3.5 - 5.0	6	6	6	6	10	15
	5.1 - 7.0	10	10	10	10	15	15
	7.1 - 12.0	15	15	15	15	20	20
	12.1 - 20.0	20	20	20	20	25	-

EC DECLARATION OF CONFORMITY



Trend declare that this product mentioned above is in compliance with 2006/42/EC, EN 60745-1, EN 60745-2-17.

This product also complies with Directives 2004/108/EC, 2011/65/EU and the following harmonised standards EN 55014-1, EN 55014-2, EN61000-3-2 and EN61000-3-3.

Managing Director
Jeff Willcocks

Trend Machinery & Cutting Tools Ltd.
Unit 6 Odhams Trading Estate
St Albans Road, Watford
Herts, WD24 7TR
United Kingdom

Level of sound pressure according to 2006/42/EC, measured according to EN 60745:

Lpa (sound pressure) 83 dB(A) 1
Lwa (acoustic power) 94 dB(A) 2



INFORMATION ON NOISE/VIBRATION

The noise level when working can exceed 85 dB(A).

Wear ear protection!

Vibration total values (triax vector sum) determined according to EN 60745:

Vibration emission value a_h

$a_h =$ m/s² <2.5

The vibration emission level given in this information sheet has been measured in accordance with EN 60745 and may be used to compare one tool with another. It may be used for a preliminary assessment of exposure.

WARNING: The declared vibration emission level represents the main application of the tool. However if the tool is used for different applications, with different accessories or poorly maintained, the vibration emission may differ. This may significantly increase the exposure level over the total working period.

An estimation of the level of exposure to vibration should also take into account the times when the tool is switched off or when it is running but not actually doing the job. This may significantly reduce the exposure level over the total working period.

Identify additional safety measures to protect the operator from the side effects of vibration such as: maintain the tool and the accessories, keep hands warm, organisation of work patterns.

MARKINGS ON TOOL

The following pictures are shown on the tool.



Read instruction manual before use.

Date Code Position

The year of manufacture is on the rating plate.

ITEMS ENCLOSED

- 1 x Parallel side-fence with micro adjuster
- 1 x Fence rods (pair)
- 2 x Adjustable fence cheeks with fixing screws
- 1 x Collet 1/4" (6.35mm) UK & Eire
- 1 x Collet 8mm* UK & Eire, Europe
- 1 x Spanner (17mm A/F)
- 1 x Guide bush 20mm and fixing screws
- 1 x Beam trammel attachment
- 1 x Dust extractor spout
- 1 x Grip knob direction arrow sticker
- 1 x Fine Height Adjuster*
- 1 x Instruction manual
- 1 x Guarantee registration card

* not Basic models

DESCRIPTION OF PARTS

- (A) Plunge locking grip knob
- (B) Depth of cut scale
- (C) Depth stop
- (D) Motor housing
- (E) Power cable
- (F) On/Off switch: MK1

- (G) Fixed Grip knob
- (H) Spindle lock
- (I) Collet nut
- (J) Dust spout 35mm dia.
- (K) Thumb knob with anti-vibration spring to secure fence rods
- (L) Router base
- (M) Template guide bush dia. 20mm
- (N) Collet
- (O) Adjustable fence cheek
- (P) Thumb knob with anti-vibration spring for side-fence rod
- (Q) Beam trammel attachment
- (R) Side-fence
- (S) Knob for micro-adjustment
- (T) 3-way turret stop
- (U) Spanner (17mm A/F)
- (V) Thumb knob with anti-vibration spring for depth stop

- (W) Fence rods dia. 8mm x 300mm
- (X) Variable speed control dial
- (Y) Template guide bush fixing screw
- (Z) Grip knob direction arrow sticker

- (AA) Fine height adjuster*
- (AB) T5MK2 trigger lock

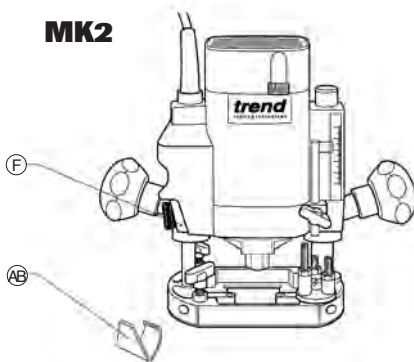
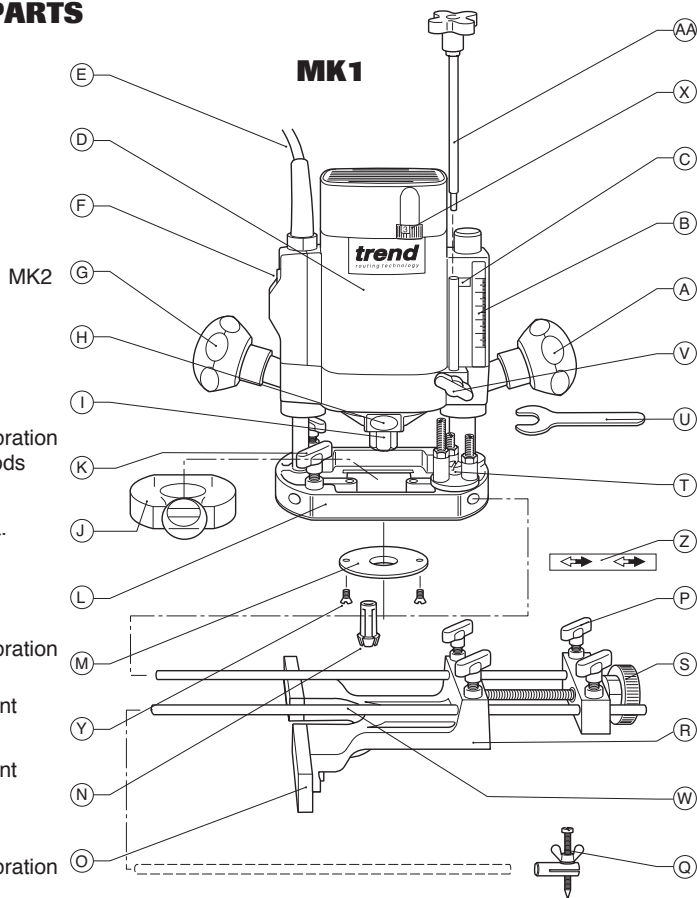

*not Basic models

ASSEMBLY & ADJUSTMENT

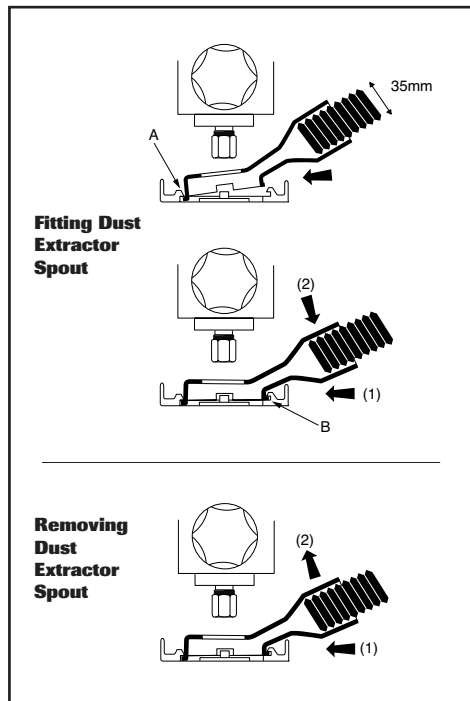

Fitting and Removing the Dust Extractor Spout

- Insert the extractor spout in channel 'A' of the routing base.

The extractor spout is suitable for dust extractors with a hose diameter of 35mm. The spout can be installed from either side. To ensure maximum plunge it is recommended to fit spout to back of machine.

- Press the extractor spout down and forward until it latches into channel 'B'.

Dismantle in reverse order.



Whenever possible use the dust extraction spout with a suitable extractor when routing.

Fitting the plunge grip knob direction arrow sticker

- Remove direction arrow (2) from backing paper and apply to plunge locking grip knob (1).
- Orientate label so that solid arrow head points away from the front of the router.
- Wrap arrow around grip knob neck, ensure it is correctly positioned and firmly stuck down.

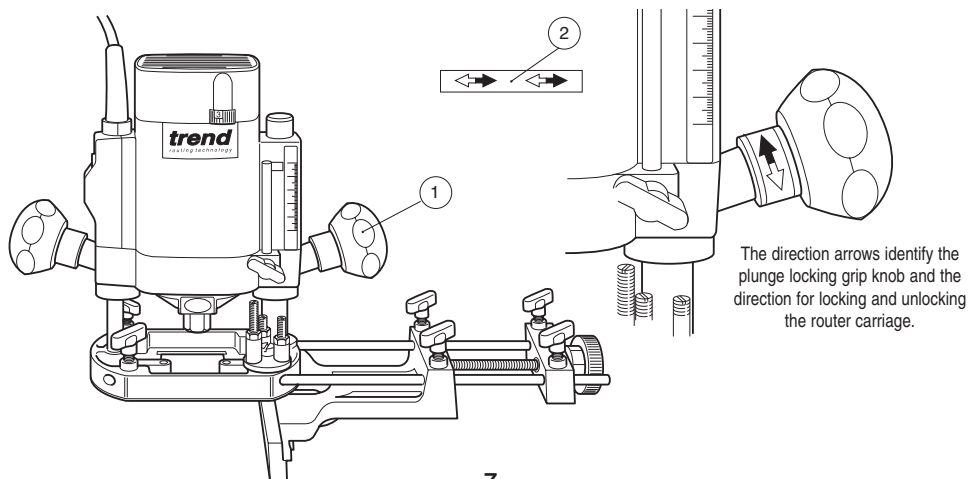

How to Fit and Remove a Router Cutter

Fitting Cutters

- Insert at least $\frac{3}{4}$ of the shank length of the cutter (1) into the collet.
- Press the spindle lock (2) forward until the router spindle is locked (you may need to turn the spindle slightly to engage it).
- Tighten the collet nut with the spanner (3). Do not use excessive force.

Removing Cutters

- Undo the 17mm A/F collet nut with the spanner.
- Keep turning the spanner until the collet nut tightens and then loosens again. This is the fail-safe mechanism releasing the collet.
- The cutter should now slide out.
- Each time you finish using a cutter, remove it and store it in a safe place.

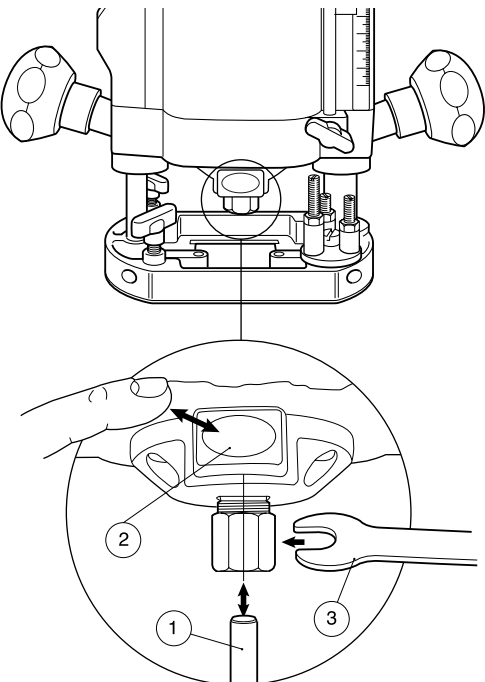

Correct Sequence for Fitting Collet, Nut and Cutter

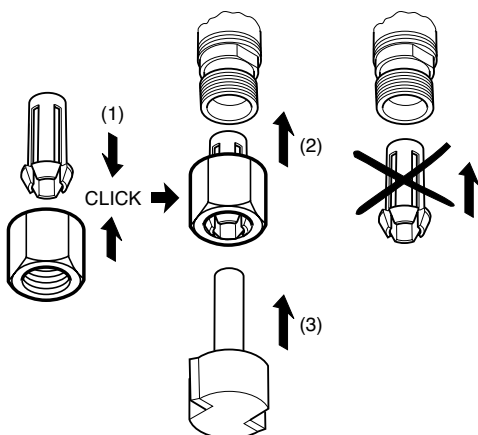

- **Do not tighten the collet without a cutter fitted.**
- **Always use cutters with shanks which match the diameter of the collet.**
- **Do not use cutters larger than 40mm unless the router is fitted in a router table.**

Setting the Electronic Speed Control Dial

The speed is infinitely variable from 9,000 to 27,000 rpm using the electronic speed control dial (1) for uniform cutting results in all types of wood, plastics and in aluminium.

- Turn the electronic speed control dial to the required level. The dial is numbered from 1 to 5 and corresponds to router speeds from 9,000 rpm to 27,000 rpm.
- Generally, use the lower settings for large diameter cutters and the higher settings for small diameter cutters. The correct setting will also depend on the density of the material, depth of cut and feed speed of the router, as severe loss of rpm denotes motor overload. In most cases the slowest speed required for large cutters with smaller shank sizes is Dial No 3-4.

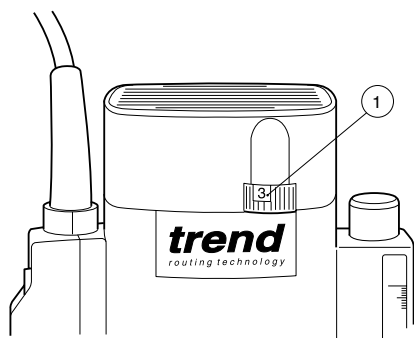

Dial No.	Router Speed
1	9,000 rpm
2	13,000 rpm
3	18,000 rpm
4	23,500 rpm
5	27,000 rpm

Fitting the Fine Height Adjuster Optional Accessory Ref. FHA/001

The optional fine height adjuster should be used when fine adjustment is required. This is especially recommended when using our dovetail jig or router table.

- Remove the depth stop and replace it with the fine height adjuster.
- Leave the plunge locking grip knob and the thumb knob loose and thread the end of the fine height adjuster onto the longest screw.
- Set the depth of cut by turning the fine height adjuster handle until the correct height is reached. Then lock the carriage clockwise with the plunge locking grip knob.



Remember to always unlock the carriage by turning the plunge locking grip knob anti-clockwise when adjusting the height with the fine adjuster.

Fixing Points for Accessories

The router has two threaded holes M6 in its base that allow fitting of accessories and also fitting to router tables.

A whole range of accessories are shown in the Trend Routing Catalogue.

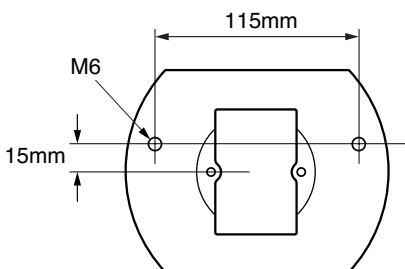
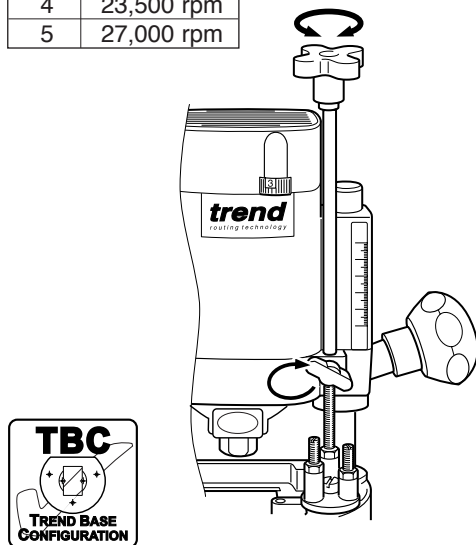

OPERATION



To reduce the risk of serious personal injury, always use proper hand position as shown.



To reduce the risk of serious personal injury, always hold securely in anticipation of a sudden reaction.

Proper hand grip requires one hand on each grip as shown.

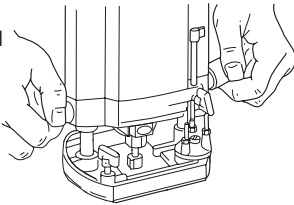

Cutting Direction



The direction of routing must always be opposite to the cutter's direction of rotation, otherwise there is a risk of kick-back.

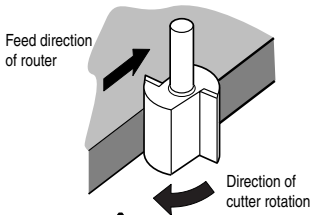

Feed Direction

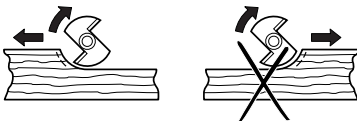

When routing along an edge, the direction of the router travel should be against that of the rotation of the cutter. This will create the correct cutting action and prevent the cutter 'snatching'. It will also pull the router towards the workpiece and hence the side-fence or guide bearing will be less likely to wander from the edge of the workpiece.

Feed Speed



The speed at which the cutter is fed into the wood must not be too fast that the motor slows down, or too slow that the cutter leaves burn marks on the face of the wood. Practice judging the speed by listening to the sound of the motor when routing.

Sequence of plunging

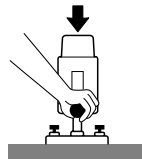

Step One

Plunge down and lock the motor carriage, with the plunge locking lever.

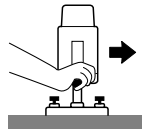

Step Two

Carry out the routing operation.

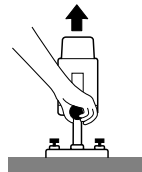

Step Three

Release the plunge locking lever and the motor carriage returns to the normal position.

Moulding Natural Timbers



When edge moulding natural timbers, always mould the end grain first, followed by the long grain. This ensures that if there is 'breakout', this will be removed when the long grain is routed.

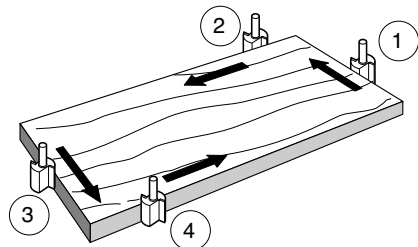

Side-Fence Routing

The side-fence is used to guide the router when moulding, edge profiling or rebating the edge of the workpiece or when routing grooves and slots in the centre of the workpiece, parallel to the edge.

The edge of the workpiece must be straight and true. The cheeks are adjustable and should be set ideally with a 3–4mm gap each side of the cutter.

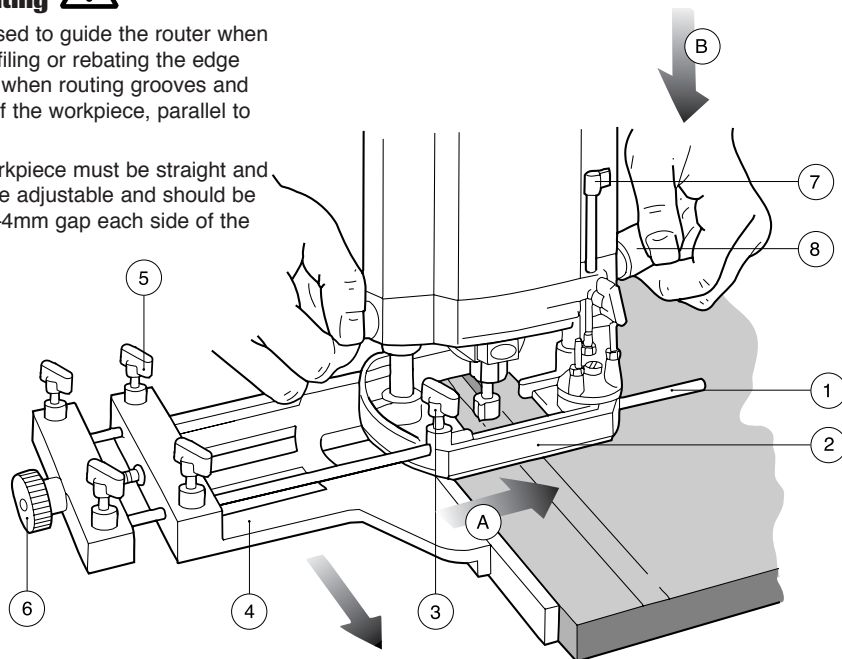

Fitting and using the Side-Fence

- Make sure the thumb knobs (3) are fully released. Slide the guide rods (1) into the routing base (2) and tighten the thumb knobs (3).
- Adjust the side-fence (4) to the required distance and clamp in place with the thumb knobs (5).
- Then lower the cutter height until the cutter is just above the workpiece.
- Fine adjustments are possible by slackening the thumb knobs (5), adjusting the micro-adjustment knob (6) and securing it again with the thumb knobs (5). One revolution of the micro-adjustment knob (6) equals 1.25mm of side-feed.
- Lower the cutter onto the workpiece and set the cutter height by raising the depth stop (7) the required distance.
- Switch on the router and when the cutter reaches full speed, gently lower the cutter into the workpiece and lock the plunge.

- Feed along the timber, keeping sideways pressure (A) to ensure the side-fence does not wander away from the workpiece edge and downward pressure on the inside hand (B) to prevent the router from tipping.
- When finished, raise the router, secure with the plunge locking grip knob (8) and switch off.

When starting the cut, keep the pressure on the front cheek (C) until the back cheek contacts the workpiece edge.

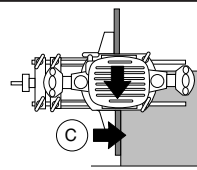

At the end of the cut, keep pressure on the back cheek (D) until the cut is finished. This will prevent the router cutter swinging in at the end of the workpiece and 'nipping' the corner.

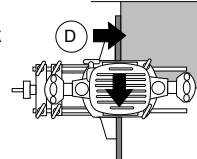

Using the Guide Bush

The 20mm guide bush (1) is fastened to the router's base from beneath using the two M5 countersunk machine screws (2) supplied.

Routing with a Template 

The guide bush is used in conjunction with a template when the routing is repetitive or the workpiece is complex in shape. The template is fixed to the upper surface of the workpiece. A cutter is chosen with a diameter which will pass through the centre of the bush leaving enough clearance. The cutter can be straight or shaped. The router can then be guided around the template so that the shape of the template will be replicated.

Making the Template 

The template is cut from 6mm or 1/4" MDF, plywood or plastic to the shape required. The guide bush offset needs to be allowed for when calculating the shape of the template. The template must be smaller by an amount equal to the difference between the 'outer edge of the guide ring' and the 'outer edge of the cutter'. See below for the offset calculation. The edge of the template must be free of imperfections as these will be replicated in the final workpiece.

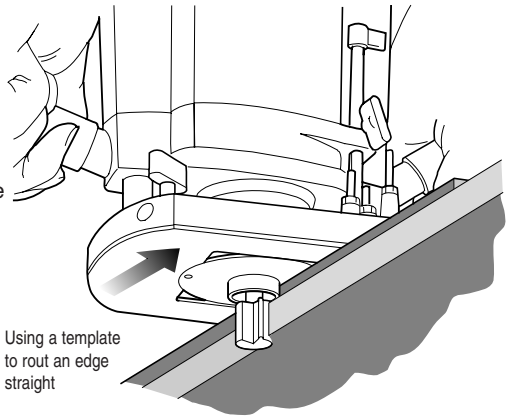
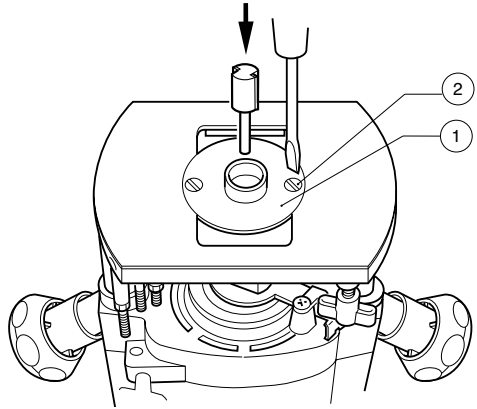

Calculations for template offset

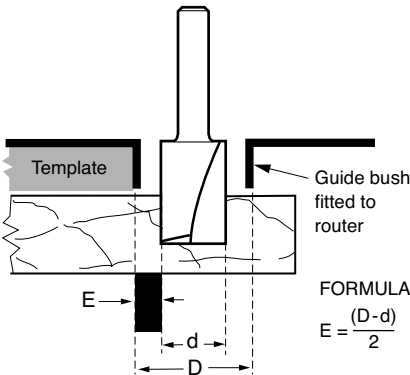

Alternatively it can be used for cutting shapes or making panelling grooves.

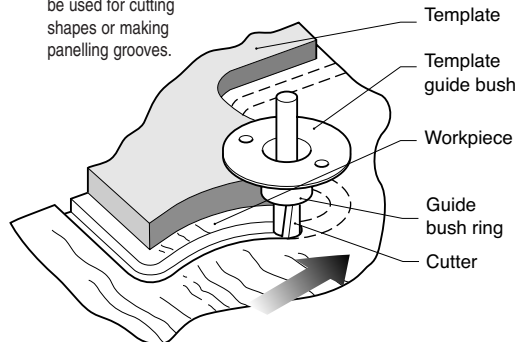

Beam Trammel Routing

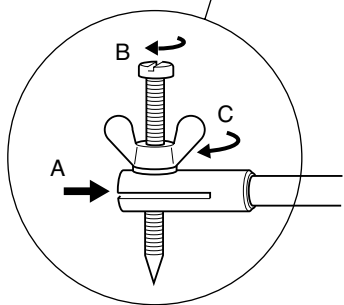
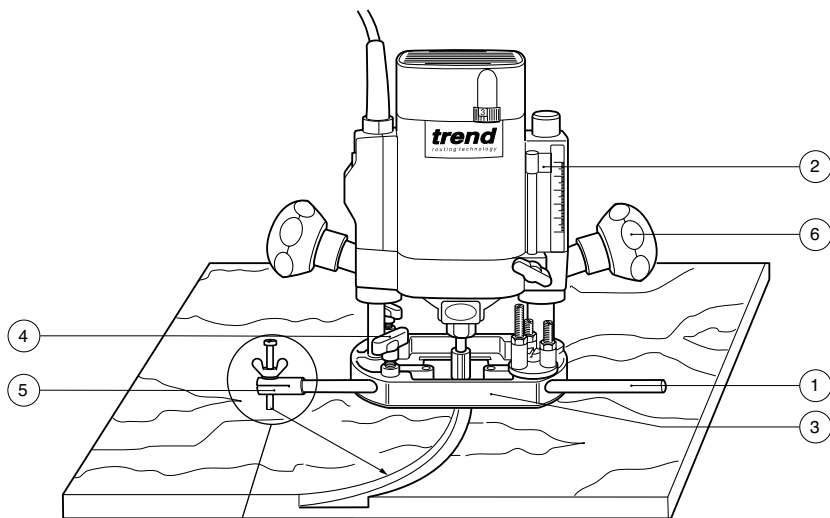

Fitting the beam trammel attachment

- Fit the beam trammel attachment (A) to the end of one rod and tighten wing nut (C) securely.
- Height adjustment of the pivot point can be achieved by loosening wing nut (C) and rotating screw (B).
- Once set to the correct height, lock securely wing nut (C).

Cutting Arcs with the Router



- Place the machine on the workpiece.
- Set the cutting depth using the depth stop (2).
- Fasten the fence rod (1) in the routing base (3) with the thumb knob (4).
- Fit on the beam trammel point (5) as shown.
- Measure the radius and fix the point of the beam trammel in position.
- Switch on the machine.
- After releasing the plunge locking knob (6), lower the machine slowly as far as the depth stop and lock it there.
- Cut grooves, rebates etc. at a steady rate of feed, in an anti-clockwise direction. Ensure the beam trammel point does not move.
- When finished, release locking knob to raise the machine.
- Switch off the machine.

Bearing Guided Cutters

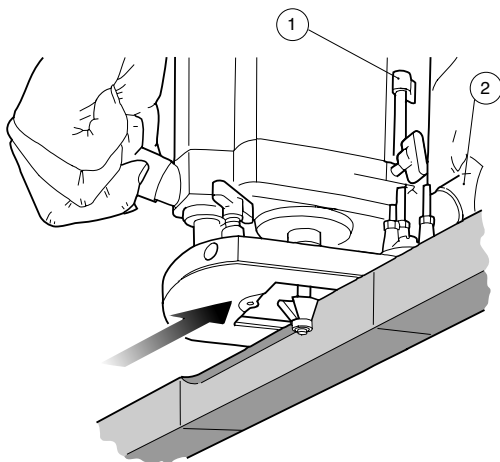

- Fit the bearing guided cutter into the router collet.
- Place router onto the workpiece.
- Set height of cutter using the depth stop (1).
- Switch on the machine.
- After releasing the plunge locking grip knob (2), lower the machine slowly as far as the depth stop.
- With bearing of cutter running along board edge, mould the edge of the workpiece by moving the router in the direction shown.
- A continuous motion should be used to prevent burning of the workpiece. When possible, take a number of passes at increased cutter depths. A light final pass will produce a good finish.
- When complete, retract the carriage by releasing the locking grip knob.
- Switch off the router.

Ball Bearing Guided Cutters



Edge profiling and shaping cutters are available with a bearing fitted to the end. This enables shaped or straight workpieces to be routed without the need for a guiding device such as a side-fence or batten.

The edge must be free from imperfections as these will be reflected in the finish of the mould. Often alternative diameters of bearings are offered which will change the shape of the resulting mould.

With certain shapes such as the chamfer cutter below, increasing the depth of cut will produce a larger chamfered edge.

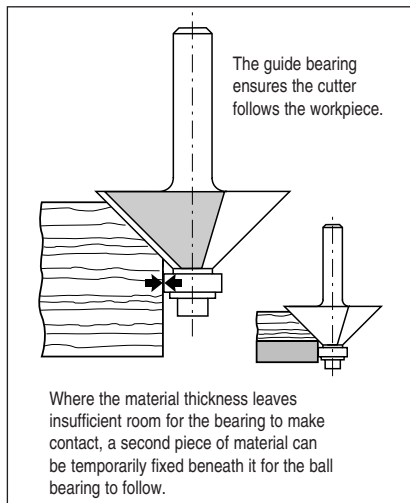

Keep downward pressure with the inside hand to prevent the router from tipping.

Freehand Routing with the Router

The T5 can also be used for signwriting or creative freehand work without any form of guide.

With practice, numbers or name plate designs can be routed freehand. Draw the design or motif on the workpiece and then rout the design, taking shallow passes.

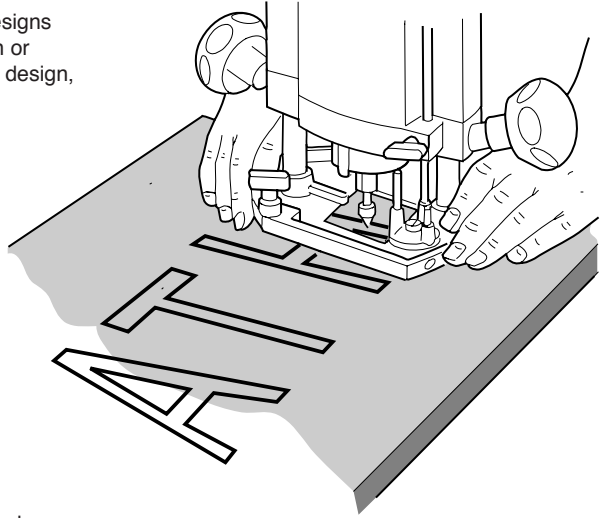
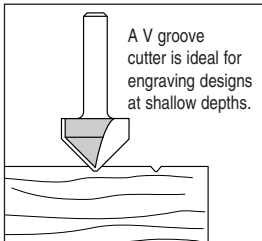

Batten Routing

Where a side-fence cannot be used, it is also possible to guide the router along a batten clamped across the workpiece (with an overhang at both ends).

Guidance from a batten is similar to that obtained from a side-fence. This method is appropriate if the edge of the workpiece is not straight or is not very smooth or simply the guide rods of the side-fence are too short for the job.

Use the straight edges of the router base and calculate the distance required from the edge of the batten to the cut required. Always check that the clamps do not obstruct the path of the router before starting the cut.

Standard technique is used, and side pressure applied to ensure the router does not wander from the batten.

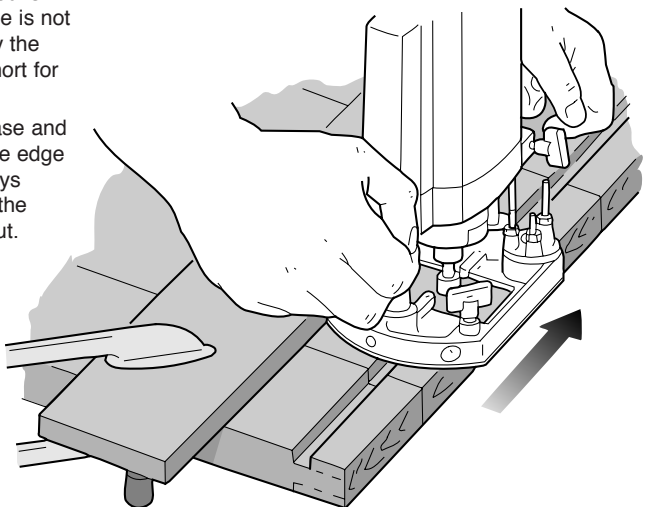

MAINTENANCE AND CARE

Cleaning

- Keep the machine clean at all times. Some maintenance products and solvents may damage the plastic parts, these include products containing Benzene, Trichloroethylene Chloride and Ammonia.
- Never use any caustic agents to clean the plastic parts.

Changing Brushes



Ensure machine is isolated from power supply.

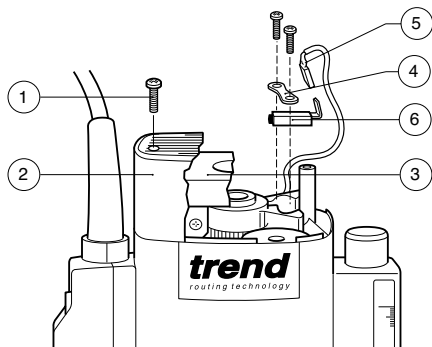

It is advisable to have the brushes replaced by an authorised Trend Service Agent. The router will also be given a thorough inspection.

- Undo the single screw (1) in the top of the vent housing. Slide the vent housing (2) off.
- Pull back the spring retaining clip (4). Take care not to bend or distort the coil spring.
- Disconnect the wire (5) and remove the carbon brush (6).
- Insert the new brush and press the connector firmly on to the tag (3). Refit the cover.
- Always use original T5 spare parts.

Lubrication

- The bearings of the machine need no lubrication, as they are sealed. The two plunge columns on the routing base should be slightly oiled from time to time.
- Keep the cooling vents on the motor housing clean and unobstructed at all times. Blow out any dust and dirt at regular intervals.
- Visually check the carbon brushes. In the event of excessive sparking, they may need changing.
- After about 40 operating hours inspection by a authorised Trend service agent is recommended.

Storage

- After use return the tool to its storage case.

ENVIRONMENTAL PROTECTION

Recycle raw materials instead of disposing as waste.

Accessories and packaging should be sorted for environmental-friendly recycling.



Separate collection.

This product must not be disposed of with normal household waste.

Household User

Local regulations may provide for separate collection of electrical products from the household, at municipal waste sites or by retailer when you purchase a new product.

Please call Trend Customer Services for advice as to how to dispose of unwanted Trend electrical products in an environmentally safe way or visit www.trend-uk.com

Business Users

Please call Trend Customer Services for disposal of unwanted Trend electrical products.

GUARANTEE

The unit carries a manufacturers guarantee in accordance with the conditions on the enclosed guarantee card.

For the location of your nearest Trend Service Agent, please call Trend Customer Services or see our stockist locator at www.trend-uk.com.

Please use only Trend original spare parts.

T5 MK1 & MK2 V2 - SPARE PARTS LIST			v10.0 06/2013
No.	Qty.	Desc.	Ref.
1	1	Stator Housing	WP-T5/001
2	1	Top Vent Housing	WP-T5E/002
3A	1	Base Complete V2	WP-T5/003A
4A	1	Lower Bearing Housing V2	WP-T5/004A
5	1	Spring for Revolving Guide	WP-T5/005
6	1	Ball for Revolving Guide	WP-T5/006
8A	1	Revolving Guide V2	WP-T5/008A
9	3	Nut Hex M5	WP-NUT/05
10	1	Threaded Pin M5 x 15mm Revolving Guide Cheese Head	WP-T5/010
11	7	Thumb Knob M6 Male x 12mm	WP-T5/011
12A	1	Revolving Guide Stepped Screw M6	WP-T5/012A
13	1	Threaded Pin M5 x 20mm Cheese Head	WP-T5/013
14	1	Depth Stop	WP-T5/014
15A	2	Grip Knob V2	WP-T5/015A
16	7	Spring 12mm for Thumb Knob	WP-T5/016
17	1	Switch T5, T5/EURO & T5EL V2	WP-T5E/017
18	1	Bottom Bearing 35mm x 17mm x 10mm 6003	WP-T5/018
19	2	Screw Self Tapping 4mm x 20mm Torx	WP-T5/019
20	1	Bearing Cover for Top Bearing	WP-T5/020
21	2	Machine Screw Cheese M4 x 89/45mm Pozi	WP-T5/021
23	1	2 Core Cable with Plug 240V UK T5	WP-T5/023
	1	2 Core Cable c/w Gland with Plug 240V UK T5 V2	WP-T5/023A
	1	2 Core Cable with Plug 115V UK T5L	WP-T5L/023
	1	2 Core Cable with Plug 230V Euro T5/EURO	WP-T5EURO/023
24	1	Cable Guard	WP-T5/024
25A	1	Switch Cover V2	WP-T5/025A
	1	Switch Cover T5MK2	WP-T5/2/025
26	1	Screw Self Tapping 3.5mm x 22mm Torx	WP-T5/026
26A	1	Screw Self Tapping 4mm x 25mm Torx	WP-T5/026A
27	1	Switch 240V T5MK2	WP-T5E/2/027
27A	1	Switch Lever Spring T5MK2	WP-T5E/2/027A
27B	1	Switch Lever T5MK2	WP-T5E/2/027B
28	1	Cable Clamp	WP-T5/028
29A	1	Field Complete 240V T5E & T5/EURO V2	WP-T5E/029A
	1	Field Complete 115V T5EL V2	WP-T5EL/029A
30	1	Deflector	WP-T5/030
31A	1	Armature 240V with Fan T5 & T5/EURO V2	WP-T5E/031A
	1	Armature 115V with Fan T5EL V2	WP-T5EL/031A
32	1	Carbon & Holder 240V T5 & T5/EURO (2 sets)	WP-T5E/032
	1	Carbon & Holder 115V T5EL (2 sets)	WP-T5EL/032
33	2	Brush Clamp	WP-T5/033
34	1	Guide Rods 8mm x 300mm (pair)	ROD/8x300
35A	1	Top Bearing 8mm x 22mm x 7mm 6082RSI V2	WP-T5/035A
36	1	Slotted Round Nut	WP-T5/036
37	1	Collet Nut <05/2005	CLT/NUT/T5
38	1	Threaded Pin M5 x 40mm Revolving Guide	WP-T5/038
39A	1	Collet & Nut Set 6.35mm >05/2005	CNS/T5/635
	0	Collet & Nut Set 6.0mm >05/2005	CNS/T5/6
	0	Collet & Nut Set 8.0mm >05/2005	CNS/T5/8
40	1	Spanner 17mm A/F	SPAN/17

T5 MK1 & MK2 V2 - SPARE PARTS LIST			v10.0 06/2013
No.	Qty.	Desc.	Ref.
41	6	Screw Self Tapping 4mm x 16mm Torx	WP-T5/041
42	2	Locking Washer B4	WP-T5/042
44	1	Beam Trammel for 8mm Rod	BEAM/005
45	1	Guide Bush 20mm Diameter	GB20/B
46	0	Parallel Side Fence Complete with Micro Adjuster	WP-T5/046
47	1	Parallel Side Fence Casting >05/2005	WP-T5/047A
48	1	Micro Adjuster Knurled Knob >05/2005	WP-T5/048A
49	1	Side Fence Cheeks (set) >05/2005	WP-T5/049A
50	1	Phenolic Base Plate Slider	WP-T5/050
51	4	Machine Screw Cheese M5 x 10mm Slot	WP-SCW/50
52	4	Washer 5.3mm x 10mm x 1mm	WP-T5/052
53	1	Scale	WP-T5/053
55A	1	Speed Control Circuit Board 240V T5 & T5/EURO V2	WP-T5E/055A
	1	Speed Control Circuit Board 115V T5EL V2	WP-T5EL/055A
56	1	Speed Control Dial	WP-T5E/056
57	1	Insertion Socket	WP-T5/057
58A	1	Conductor Lead Switch to Speed Control V2 (Pair)	WP-T5/058A
60A	1	Spring for Spindle Lock V2	WP-T5/060A
61A	1	Spindle Lock Body V2	WP-T5/061A
62	1	Spindle Lock Plate	WP-T5/062
63A	1	Screw 4mm x 8mm Torx	WP-T5/063A
64A	1	Washer 20mm x 8mm x 2mm Csk for Column V2	WP-T5/064A
65	1	Machine Screw Csk M5 x 10mm Slot	WP-T5/065
66	1	Plunge Column Spring	WP-T5/066
67	1	Brass Ferrule for Spring	WP-T5/067
68	2	Machine Screw Countersunk M5 x 10mm Slot	WP-SCW/13
69A	1	Rubber Sleeve V2	WP-T5/069A
70	1	Lead Field to Speed Control (Red x 90mm)	WP-T5/070
71	1	Lead Field to Speed Control (Red x 120mm)	WP-T5/071
72	1	Lead Brush to Field (Blue x 90mm)	WP-T5/072
73	1	Lead Brush to Field (Blue x 130mm)	WP-T5/073
74A	1	Dust Extraction Spout V2	WP-T5/074A
75	1	Grip Knob Direction Arrow	WP-T5/075
76	3	Machine Screw Csk M4 x 10mm Pozi	WP-SCW/48
77	0	Side Fence Complete without Micro Adjuster	WP-T5/077
78A	1	Side Fence Stud M8 x 100mm >05/2005	WP-T5/078A
79	1	Side Fence Washer 24mm x 12mm x 1.6mm	WP-T5/079
80	1	Side Fence Half Nut Hex M8	WP-T5/080
81	1	Side Fence Circlip 12mm	WP-T5/081
82	1	Side Fence Micro Adjuster Casting	WP-T5/082
83	1	O Ring 6mm x 1.5 V2	WP-T5/083
84	1	Junction Block V2	WP-T5/084
85	2	Screw M3 x 8 Pan V2	WP-T5/085
86	2	Washer 3mm V2	WP-T5/086
87	1	Magnetic Disk V2	WP-T5E/087
88	1	Spindle Lock Button V2	WP-T5/088
89	1	Spindle Lock Housing V2	WP-T5/089
90	1	Fine Height Adjuster T5EK, T5ELK & T5/EURO	FHA/001
91	1	Trigger Lock T5MK2	T5MK2/LOCK
92	1	Manual	MANU/T5

T5 MK1 V2 - SPARE PARTS DIAGRAM

v10.0 06/2013

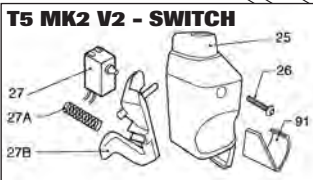
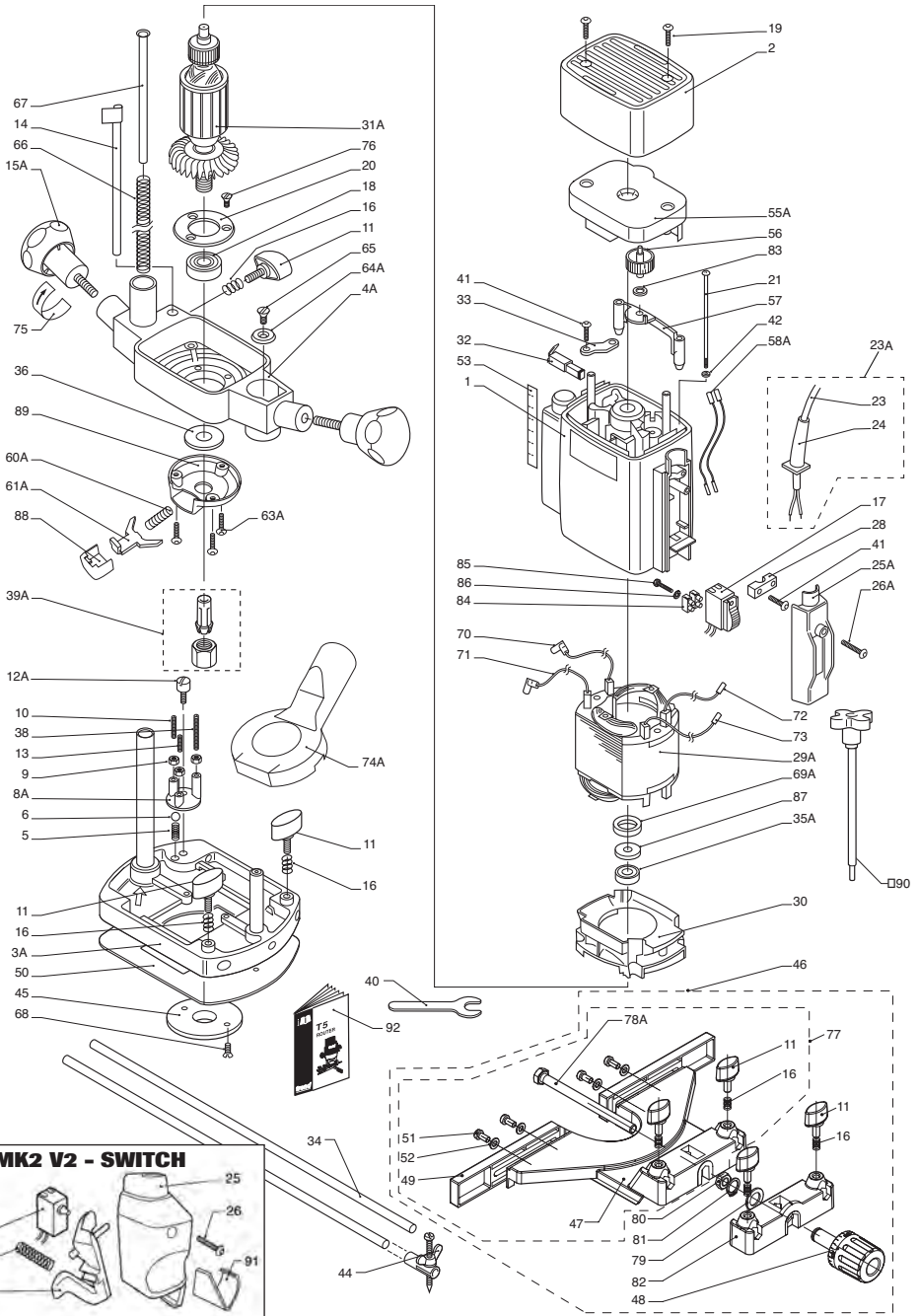

MANUT5 v10.0



RECYCLABLE

Trend Machinery & Cutting Tools Ltd.

Odhams Trading Estate St Albans Road

Watford WD24 7TR England

Tel: 0044(0)1923 249911

technical@trendm.co.uk

www.trend-uk.com

© Copyright Trend 2013. No part of this publication may be reproduced, stored or transmitted in any form without prior permission. Our policy of continuous improvement means that specifications may change without notice. Trend Machinery and Cutting Tools cannot be held liable for any material rendered unusable or any form of consequential loss. E&OE

© All registered trademarks acknowledged.