



# T5 & T5MK2



**trend**<sup>®</sup>  
routing technology

Dear Customer

Thank you for purchasing this Trend product, we hope you enjoy many years of creative and productive use.

Please remember to return your guarantee card within 28 days of purchase.

## CONTENTS

<b>TECHNICAL DATA</b>	<b>1</b>
<b>SAFETY</b>	<b>2-3</b>
<b>ELECTRICAL SAFETY</b>	<b>4</b>
<b>MANUFACTURERS DECLARATION</b>	<b>5</b>
<b>ITEMS ENCLOSED</b>	<b>5</b>
<b>DESCRIPTION OF PARTS</b>	<b>6</b>
<b>ASSEMBLY &amp; ADJUSTMENT</b>	
– Dust Extractor Spout	7
– Handle Direction Arrow	7
– Switching On & Off	8
– Depth of Cut	8
– Fitting & Removing Cutters	9
– Speed Control	10
– Fine Height Adjuster	10
– Fixing Points	10
<b>OPERATION</b>	
– Cutting Direction & Feed Speed	11
– Side-fence Routing	12
– Template Guide Bush Routing	13
– Beam Trammel Routing	14
– Bearing Guided Cutters	15
– Freehand Routing & Batten Routing	16
<b>MAINTENANCE &amp; CARE</b>	<b>17</b>
<b>ENVIRONMENTAL PROTECTION</b>	<b>17</b>
<b>GUARANTEE</b>	<b>17</b>
<b>SPARE PARTS</b>	
– Spare Parts List	18-19
– Spare Parts Diagram	20

## TECHNICAL DATA

Voltage:	UK & Eire	240V
	UK & Eire only	115V
	Europe	230V
Ampage:	240V	3.8A
	115V	8A
Power input		850W
Power output		1400W
No load speed (min.)	240V	9,000-27,000 rpm
	115V	8,500-26,000 rpm
Router carriage		2 columns
Router carriage stroke		50mm
Revolver depth stop		3-step, turret stop adjustment with graduation
Collet size:	UK & Eire	1/4 inch (6.35mm)
	Europe	8mm
Cutter diameter, max.		40mm
Weight		2.7kg
Fuse:	UK & Eire	240V 13A in plug
	UK & Eire	110V 16A in mains
	Europe	230V 10A in mains

The following symbols are used throughout this manual:



Denotes risk of personal injury, loss of life or damage to the tool in case of non-observance of the instructions in this manual.



Denotes risk of electric shock.

## INTENDED USE

The router is intended for routing grooves, edges, profiles and slots as well as copy routing in wood, wood based products and plastic. At reduced speed with the appropriate router cutter fitted non-ferrous alloys can also be routed.



If you require further safety advice, technical information or spare parts, please call our technical support department on 01923 224681 or visit [www.trendmachinery.co.uk](http://www.trendmachinery.co.uk)

**SAFETY**



**WARNING:**

Observe the safety regulations in the instruction manual of the power tool to be used. Please read the following instructions carefully. Failure to do so could lead to serious injury. When using electric tools, basic safety precautions, including the following should always be followed to reduce the risk of fire, electric shock and personal injury. Also observe any applicable additional safety rules. Read the following safety instructions before attempting to operate this product.

**PLEASE KEEP THESE INSTRUCTIONS IN A SAFE PLACE.**

The attention of UK users is drawn to The Provision and Use of Work Equipment Regulations 1998, and any subsequent amendments.

Users should also read the HSE/HSC Safe Use of Woodworking Machinery Approved Code of Practice and Guidance Document and any amendments.

Users must be competent before using our products.

**IMPORTANT NOTE:**

Residual Risk. Although the safety instructions and operating manuals for our tools contain extensive instructions on safe working with power tools, every power tool involves a certain residual risk which cannot be completely excluded by safety mechanisms. Power tools must therefore always be operated with caution!

**General**

1. Disconnect power tool when making any adjustments. When not in use, before servicing and when changing accessories such as cutters, disconnect power tool and attachment from power supply. Ensure the machine is switched off before plugging tool in or connecting to a power supply.
2. Always mount the power tool, accessory or attachment in conformity with the present instructions. The tool should not be modified or used for any application other than that for which it was designed.
3. Keep children and visitors away. Do not let children or visitors touch the tool, accessory or attachment. Keep children and visitors away from work area. Make the workshop child proof with padlock and master switch.
4. Dress properly. Do not wear loose clothing or jewelry, they can be caught in moving parts. Rubber gloves and non-skid footwear is recommended when working outdoors. Wear protective hair

covering to contain long hair.

5. Consider working environment. Do not use the product in the rain or in a damp environment. Keep work area well lit. Do not use power tools near gasoline or flammable liquids. Keep workshop at a comfortable temperature so your hands are not cold. Connect machines that are used in the open via a residual current device (RCD) with an actuation current of 30 mA maximum. Use only extension cables that are approved for outdoor use.
6. The accessory or attachment must be kept level and stable at all times.
7. Keep work area clean. Cluttered workshops and benches can cause injuries. Ensure there is sufficient room to work safely.
8. Use the attachment with the power tools and accessories specified in this manual only. Do not force the tool or attachment to do a job for which it is not designed.
9. Secure idle tools. When not in use, tools should be stored in a dry and high or locked up place, out of reach of children.
10. For best control and safety use both hands on the power tool and attachment. Keep both hands away from cutting area. Always wait for the spindle and cutter to stop rotating before making any adjustments.
11. Always keep guards in place and in good working order.
12. Remove any nails, staples and other metal parts from the workpiece.
13. Maintain tools and cutters with care. Keep cutters sharp and clean for better and safer performance. Do not use damaged cutters. Follow instructions for lubricating and changing accessories. Keep handles dry, clean and free from oil and grease.
14. Maintain accessories. Do not use damaged accessories. Only use accessories recommended by the manufacturer.
15. Check damaged parts. Before operation inspect the attachment, the power tool, the cable, extension cable and the plug carefully for signs of damage. Check for alignment of moving parts, binding, breakage, mounting and any other conditions that may effect its operation. Have any damage repaired by an Authorised Service Agent before using the tool or accessory. Protect tools from impact and shock.
16. Do not use tool if switch does not turn

it on or off. Have defective switches replaced by an Authorised Service Agent.

17. Don't over reach. Keep proper footing and balance at all times. Do not use awkward or uncomfortable hand positions.
18. Don't abuse the cable. Never carry power tool or accessory by cord or pull it to disconnect from the socket. Keep cord from heat, oil and sharp edges. Always trail the power cord away from the work area.
19. Connect dust extraction equipment. If devices are provided for the connection of dust extraction and collection facilities, ensure these are connected and properly used.
20. Check all fixing and fastening nuts, bolts and screws on power tool, attachment and cutting tools before use to ensure they are tight and secure. Periodically check when machining over long periods.
21. Stay alert. Watch what you are doing. Use common sense. Do not operate tools when you are tired, under the influence of drugs or alcohol.
22. Personal Protective Equipment (PPE). All PPE must meet current UK and EU legislation.
23. Do not leave tools running unattended. Do not leave tool until it comes to a complete stop.
24. Always clamp workpiece being machined securely.
25. Only use cutting tools for woodworking that meet EN847-1/2 safety standards, and any subsequent amendments.
26. Vibration levels. Hand held power tools produce different vibration levels. You should always refer to the specifications and relevant Health & Safety Guide.

**Routing Safety**

1. Disconnect router power tool. When not in use, before servicing and when changing accessories such as cutters, disconnect router and attachment from power supply.
2. Ensure router cutter has stopped rotating before changing it. Never use the spindle lock as a brake.
3. Remove adjusting keys and spanners. Form the habit of checking to see that keys and adjusting spanners are removed from the router tool, cutter and attachment before turning router on. Make sure cutter can rotate freely.
4. Noise. Take appropriate measures for the protection of hearing if the sound pressure of 85dB(A) is

exceeded. Routing sound pressure may exceed 85dB(A), so ear protection must be worn.

5. Eye protection. Wear safety goggles, spectacles or visors to protect the eyes from ejected waster particles.
6. Respiratory protection. Wear a face or dust mask, or powered respirator. Dust masks/filters should be changed regularly.
7. Do not switch router on with the cutter touching the workpiece.
8. The direction of routing must always be opposite to the cutter's direction of rotation. Do not back-cut or climb-cut.
9. At the end of the cut, release the router plunge and allow spindle to stop rotating before putting machine down.
10. Check before cutting that there are no obstructions in the path of the router. When cutting through the full thickness of the workpiece, ensure there are no obstacles beneath workpiece, and that a sacrificial work surface is used.

**Router Cutter Safety**

1. Cutting tools are sharp. Care should be taken when handling them.
2. Always use cutters with a shank diameter corresponding to the size of the collet installed in your tool.
3. Always run router cutters at the spindle speed recommended and marked accordingly. Ensure cutter has reached correct speed before entering workpiece. Recommended speeds can be found on the packaging, in cutter instructions, in the Trend Routing Catalogue or on our website.
4. Always use router cutters in a router. Router cutters must not be used in a drill. Drill and boring bits must not be used in a router. Router cutters must only be used for the material cutting application for which they are designed. Do not use on metal or masonry.
5. Never use cutters with a diameter exceeding the maximum diameter indicated in the technical data of the powertool or attachment used.
6. Do not drop cutters or knock them against hard objects. Do not use cutters that are damaged.
7. Cutters should be kept clean. Resin build up should be removed at regular intervals with Resin Cleaner<sup>®</sup>. The use of a dry lubricant (Trendcote<sup>®</sup> PTFE) will act as a preventative. Do not use PTFE spray on plastic parts.
8. When using stacked tooling (multi-

blade, block and groover etc.) on a spindle arbor, ensure that the cutting edges are staggered to each other to reduce the cutting impact.

9. Cutter shanks should be inserted into the collet to the line indicated on the shank. This ensures that at least ¾ of the shank length is held in the collet. Do not over-tighten the collet nut as this will score the shank and create a weakness and fracture point.
10. Observe the correct assembly instructions in the router instruction manual for fitting the collet and nut. Observe the router power tool manual instructions on fitting cutters correctly.
11. It is advisable to periodically check the collet and collet nut. A worn, distorted or damaged collet can cause vibration and damage the shank, and should be replaced. Worn collet nuts should be replaced.
12. Do not take deep cuts in one pass; take several shallow or light passes to reduce the side load applied to the cutter. Too deep a cut in one pass can stall the router.
13. Very small diameter cutters must be handled and used with care.
14. Always return cutter to its packaging after use.
15. Should you experience excessive vibration during use stop immediately. Have the eccentricity of the router, router cutter and clamping system checked by a qualified repair agent.
16. All fastening screws and nuts should be tightened using the appropriate spanner or key in accordance with the manufacturers instructions.

**Using Routers In A Fixed Position**

1. Attention should be made to the HSE's Safe Use of Vertical Spindle Moulding Machines Information Sheet No.18 and any revisions.
2. After work, release the router plunge to protect the cutter.
3. Always use a push-stick or push-block when making any cut less than 300mm in length or when feeding the last 300mm of the cut.
4. The opening around the cutter should be reduced to a minimum using suitably sized insert rings in the table and closing the back fence cheeks or fitting a false fence on the back fence.
5. Whenever possible use a work holding device or jig to secure component being machined.
6. Ensure attachment is securely fitted to the workbench, with table surface at

approximately hip height.

7. Ensure a No-Volt Release Switch is fixed to or adjacent to the attachment, is easily accessible and that it is used correctly.
8. In router table (inverted) mode, stand to the front right of the table. The cutter will rotate anti-clockwise when viewed from top so the feed direction is from the right (against the rotation of the cutter).
9. In overhead mode, stand to the front left of the machine table and the feed direction is from the left.
10. Do not reach underneath table or put your hands or fingers at any time in the cutting path while tool is connected to a power supply.
11. Never thickness timber between the back of the cutter and the backfence.

**Useful Advice When Routing**

1. Judge your feed rate by the sound of the motor. Feed the router at a constant feed rate. Too slow a feed rate will result in burning.
2. Take many light passes rather than one deep cut to reduce the side load applied to both router and router cutter.
3. Trial cuts should be made on waste material before starting any project.
4. When using some attachments including a router table or dovetail jig, the use of a fine height adjuster is highly recommended.
5. When using a template guide bush, ensure there is sufficient clearance between cutter tip and inside edge of bush and that it cannot come into contact with collet and nut. Ensure cutter and guide bush are concentric.

**Router Cutter Maintenance**

1. Composite cutting tools (brazed tip) must be maintained by a competent person i.e. a person of training and experience, who has knowledge of the design requirements and understands the levels of safety to be achieved.
2. The design of composite tools must not be changed in the process of maintenance. When re-grinding the tool, care must be taken not to cause weakening of the body or the connection between the cutting edge and the body.
3. Replacement parts must meet Trend specification.
4. Tolerances which ensure correct clamping by the collet shall be maintained.

**ELECTRICAL SAFETY**



**Power Supply**

The electric motor has been designed for one voltage only. Always check that the power supply corresponds to the voltage on the rating plate. Machines marked for 230 volt can also be operated from a 220 volt supply.



The T5 is double insulated in accordance with EN 50144; therefore no earth wire is required.

**Mains Plug Replacement (UK & Ireland only)**

Always check the condition of the cable and plug before starting with your work.

Should your mains plug need replacing and you are competent to do this, proceed as instructed below. If you are in doubt, contact an authorised Trend repair agent or a qualified electrician.

- Disconnect the plug from the supply.
- Cut off the plug and dispose of it safely; a plug with bared copper conductors is dangerous if engaged in a live socket outlet.
- Only fit 13 Amperes BS 1363A approved plugs fitted with a 13 Amp A.S.T.A approved BS 1362 fuse (1).
- The cable wire colours, or a letter, will be marked at the connection points of most good quality plugs. Attach the wires to their respective points in the plug (see below). Brown is for Live (L) (2) and Blue is for Neutral (N) (3).
- Before replacing the top cover of the mains plug ensure that the cable restraint (4) is holding the outer sheath of the cable firmly and that the two leads are correctly fixed at the terminal screws.

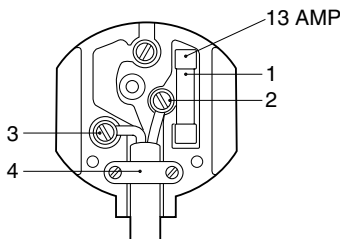

**Never connect to a light socket. Never connect the live (L) or neutral (N) wires to the earth pin marked E or ⚡.**

**Using an Extension Cable**

- If an extension cable is required, use an approved triple core extension cable suitable for the power input of this tool (see technical data).
- When using a cable reel, always unwind the cable completely.
- Also refer to the table below.

Conductor size (mm <sup>2</sup> )	Cable rating (Amperes)
0.75	6
1.00	10
1.50	15
2.50	20
4.00	25

		Cable length (m)					
		7.5	15	25	30	45	60
Voltage	Amperes	Cable rating (Amperes)					
115	0 - 2.0	6	6	6	6	6	10
	2.1 - 3.4	6	6	6	6	15	15
	3.5 - 5.0	6	6	10	15	20	20
	5.1 - 7.0	10	10	15	20	20	25
230	7.1 - 12.0	15	15	20	25	25	-
	12.1 - 20.0	20	20	25	-	-	-

230	0 - 2.0	6	6	6	6	6	6
	2.1 - 3.4	6	6	6	6	6	6
	3.5 - 5.0	6	6	6	6	10	15
	5.1 - 7.0	10	10	10	10	15	15
	7.1 - 12.0	15	15	15	15	20	20
	12.1 - 20.0	20	20	20	20	25	-

For 115V units with a power rating exceeding 1500W we recommend to use a plug to BS4343 standard.

## MANUFACTURERS DECLARATION



We declare under our sole responsibility that this product is in conformity with the following standards of standardised documents:

EN 60745, EN 55014, EN 61000, in accordance with the directives 98/37/EC, 73/23/EEC, 89/336/EEC.

Level of sound pressure according to 86/188/EEC & 98/37/EC, measured according to EN 60745:

---

Lpa (sound pressure) 83 dB(A)1

---

Lwa (acoustic power) 94 dB(A)2

Radio and TV suppression in compliance with 76/889/EEC and 82/499/EEC

### INFORMATION ON NOISE/VIBRATION



The noise level when working can exceed 85 dB(A).

**Wear ear protection!**

Weighted root mean square acceleration value according to EN 60745:

---

< 2.5 m/s<sup>2</sup> (hand arm method)

---

## ITEMS ENCLOSED

- 1 x Parallel side-fence with micro adjuster
- 1 x Fence rods (pair)
- 2 x Adjustable fence cheeks with fixing screws
- 1 x Collet 1/4" (6.35mm) UK & Eire
- 1 x Collet 8mm\* UK & Eire, Europe
- 1 x Spanner (17mm A/F)
- 1 x Guide bush 20mm and fixing screws
- 1 x Beam trammel attachment
- 1 x Dust extractor spout
- 1 x Grip knob direction arrow sticker
- 1 x Fine Height Adjuster\*
- 1 x Instruction manual
- 1 x Guarantee registration card

\* not Basic models

Managing Director  
Stephen Phillips

Trend Machinery & Cutting Tools Ltd.

**DESCRIPTION OF PARTS**

- (A) Plunge locking grip knob
- (B) Depth of cut scale
- (C) Depth stop
- (D) Motor housing
- (E) Power cable
- (F) On/Off switch: MK1

MK2

- (G) Fixed Grip knob
- (H) Spindle lock
- (I) Collet nut
- (J) Dust spout 35mm dia.
- (K) Thumb knob with anti-vibration spring to secure fence rods
- (L) Router base
- (M) Template guide bush dia. 20mm
- (N) Collet
- (O) Adjustable fence cheek
- (P) Thumb knob with anti-vibration spring for side-fence rod
- (Q) Beam trammel attachment
- (R) Side-fence
- (S) Knob for micro-adjustment
- (T) 3-way turret stop
- (U) Spanner (17mm A/F)
- (V) Thumb knob with anti-vibration spring for depth stop
- (W) Fence rods dia. 8mm x 300mm
- (X) Variable speed control dial
- (Y) Template guide bush fixing screw
- (Z) Grip knob direction arrow sticker
- (AA) Fine height adjuster\*
- (AB) T5MK2 trigger lock

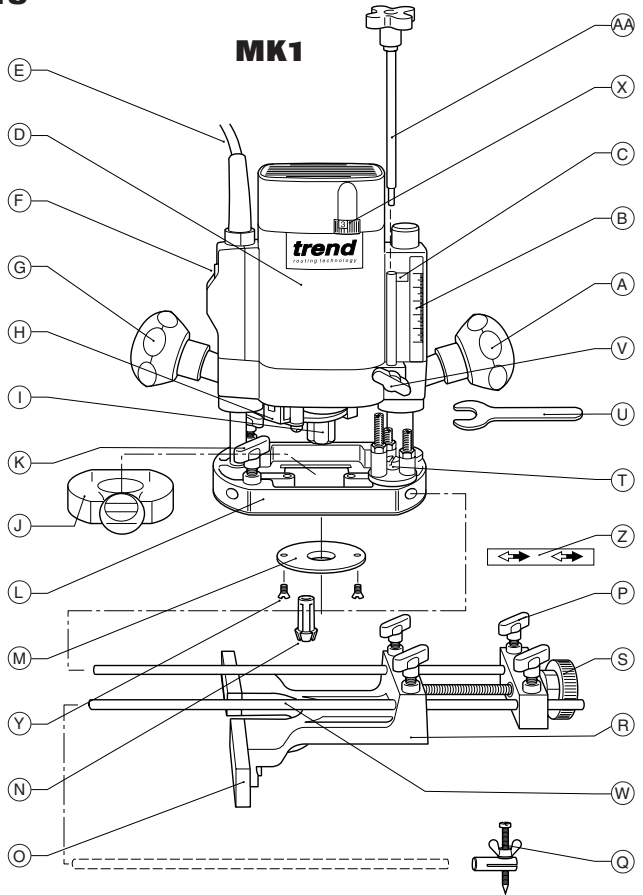

**MK2**

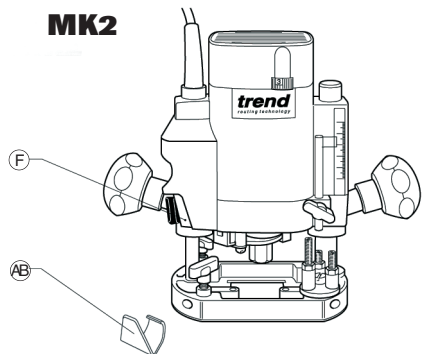

\*not Basic models

**ASSEMBLY & ADJUSTMENT**

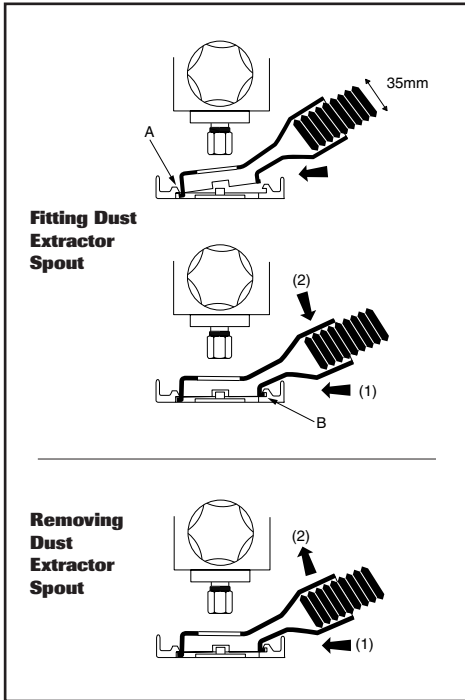

**Fitting and Removing the Dust Extractor Spout**

- Insert the extractor spout in channel 'A' of the routing base.  
The extractor spout is suitable for dust extractors with a hose diameter of 35mm.
- Press the extractor spout down and forward until it latches into channel 'B'.  
Dismantle in reverse order.



**Whenever possible use the dust extraction spout with a suitable extractor when routing.**

**Fitting the plunge grip knob direction arrow sticker**

- Remove direction arrow (2) from backing paper and apply to plunge locking grip knob (1).
- Orientate label so that solid arrow head points away from the front of the router.
- Wrap arrow around grip knob neck, ensure it is correctly positioned and firmly stuck down.

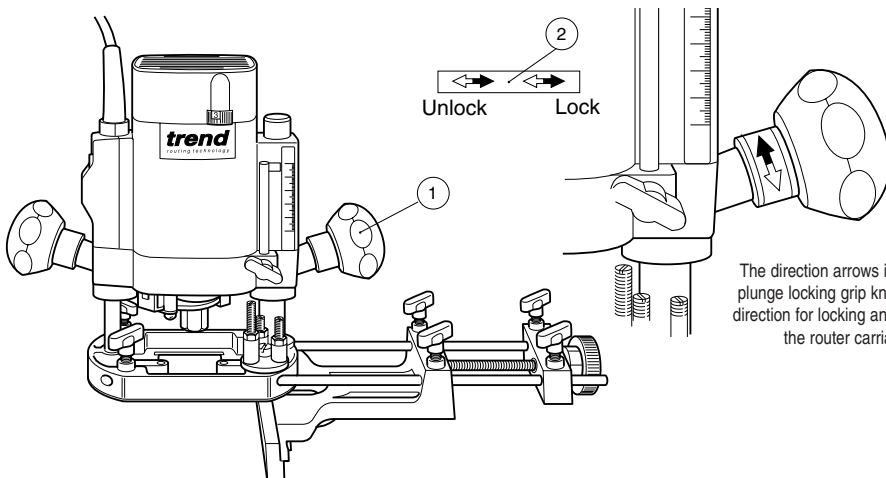

The direction arrows identify the plunge locking grip knob and the direction for locking and unlocking the router carriage.



**Switching On & Off**



**T5 MK1**

- A slide switch above the fixed grip knob is used to turn the router on and off.
- The T5 has a soft start feature when switched on and will take 1–2 seconds to reach full running speed.

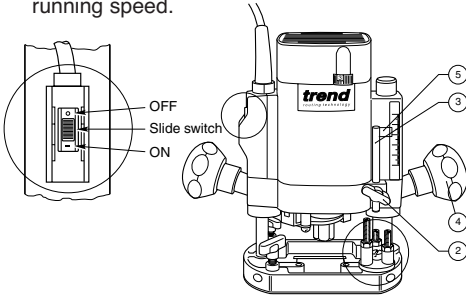

**T5 MK2**

The T5 MK2 router is fitted with an easy reach deadman's switch.

Included with the machine is the Ref. T5MK2/LOCK which allows the deadman's switch to be locked in the on position when the router is fixed to a stand or table and used in conjunction with a No-Volt Release Switch.

- Pull lever towards knob to turn router on. To switch off router release lever.
- The T5 has a soft start feature when switched on and will take 2-3 seconds to reach full running speed.

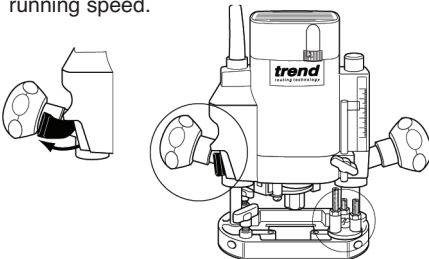

**Fitting the Ref. T5MK2/LOCK**

- Remove plug from the No-Volt Release Switch.
- Pull lever towards knob and clip lock over the knob base ensuring the front of the lock is holding the lever.
- To remove simply pull off lock.



**The T5MK2/LOCK must not be used without a No-Volt Release Switch.**

**Adjusting the Depth of Cut**



- Place the machine on the workpiece.
- Pre-set the 3-way turret stop (1) as required.
- Undo the thumb knob (2) for securing the depth stop (3).
- Undo the plunge locking grip knob (4).
- Lower the machine slowly until the cutter just touches the workpiece and secure it with the locking grip knob.
- Raise the depth stop (5) for the depth of cut required and clamp in place with the thumb knob (2).

*The gap between the depth stop and the turret stop screw determines the depth of cut.*

The rotating turret stop screws can be used for pre-setting up to three depths of cut. Their height can be adjusted using a screwdriver (6) and an 8mm A/F spanner (7).

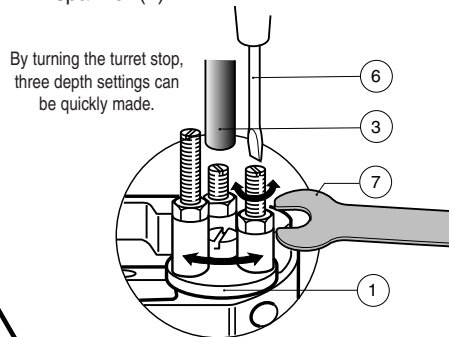

- **Make sure the machine is switched off before connecting it to the power supply!**
- **Never make adjustments when the router is running or plugged in.**
- **Deep cuts should always be routed in several passes.**

## How to Fit and Remove a Router Cutter

### Fitting Cutters

- Insert at least  $\frac{3}{4}$  of the shank length of the cutter (1) into the collet.
- Press the spindle lock (2) forward until the router spindle is locked (you may need to turn the spindle slightly to engage it).
- Tighten the collet nut with the spanner (3). Do not use excessive force.

### Removing Cutters

- Undo the 17mm A/F collet nut with the spanner.
- Keep turning the spanner until the collet nut **tightens and then loosens again**. This is the fail-safe mechanism releasing the collet.
- The cutter should now slide out.
- Each time you finish using a cutter, remove it and store it in a safe place.

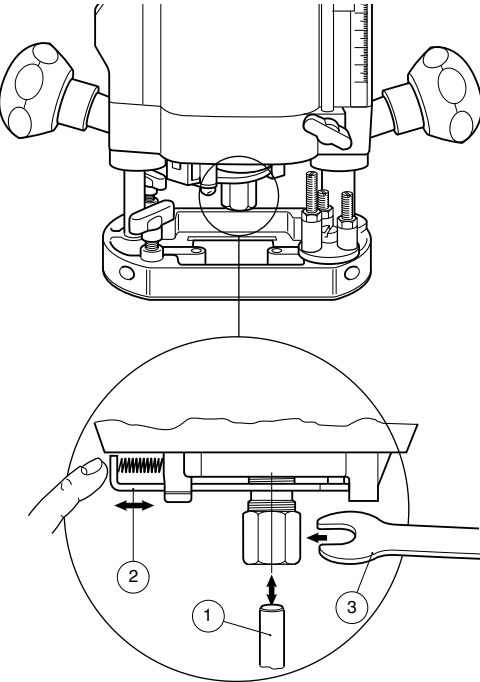

### Correct Sequence for Fitting Collet, Nut and Cutter

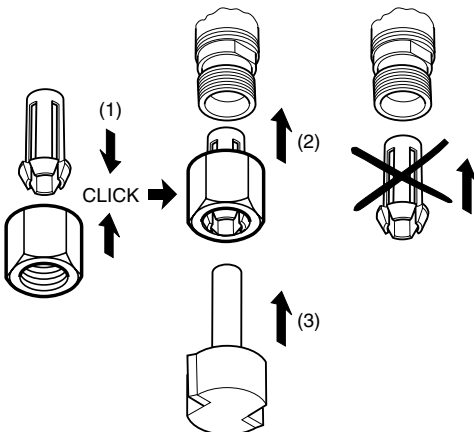

- **Do not tighten the collet without a cutter fitted.**
- **Always use cutters with shanks which match the diameter of the collet.**
- **Do not use cutters larger than 40mm unless the router is fitted in a router table.**

## Setting the Electronic Speed Control Dial

The speed is infinitely variable from 9,000 to 27,000 rpm (for 240 volt routers) using the electronic speed control dial (1) for uniform cutting results in all types of wood, plastics and in aluminium.

- Turn the electronic speed control dial to the required level. The dial is numbered from 1 to 5 and corresponds to router speeds from 9,000 rpm to 27,000 rpm (for 240 volt routers).
- Generally, use the lower settings for large diameter cutters and the higher settings for small diameter cutters. The correct setting will also depend on the density of the material, depth of cut and feed speed of the router, as severe loss of rpm denotes motor overload. In most cases the slowest speed required for large cutters with smaller shank sizes is Dial No 3-4.

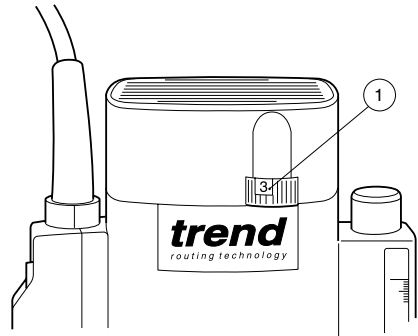

Dial No.	Router Speed
1	9,000 rpm
2	13,000 rpm
3	18,000 rpm
4	23,500 rpm
5	27,000 rpm

## Fitting the Fine Height Adjuster Optional Accessory Ref. FHA/001

The optional fine height adjuster should be used when fine adjustment is required. This is especially recommended when using our dovetail jig or router table.

- Remove the depth stop and replace it with the fine height adjuster.
- Leave the plunge locking grip knob and the thumb knob loose and thread the end of the fine height adjuster onto the longest screw.
- Set the depth of cut by turning the fine height adjuster handle until the correct height is reached. Then lock the carriage clockwise with the plunge locking grip knob.



**Remember to always unlock the carriage by turning the plunge locking grip knob anti-clockwise when adjusting the height with the fine adjuster.**

## Fixing Points for Accessories

The router has two threaded holes M6 in its base that allow fitting of accessories and also fitting to router tables.

A whole range of accessories are shown in the Trend Routing Catalogue.

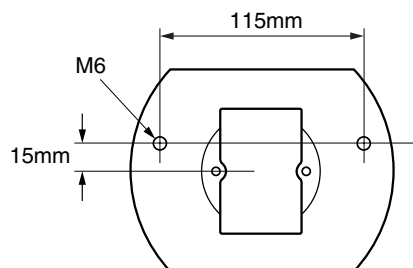
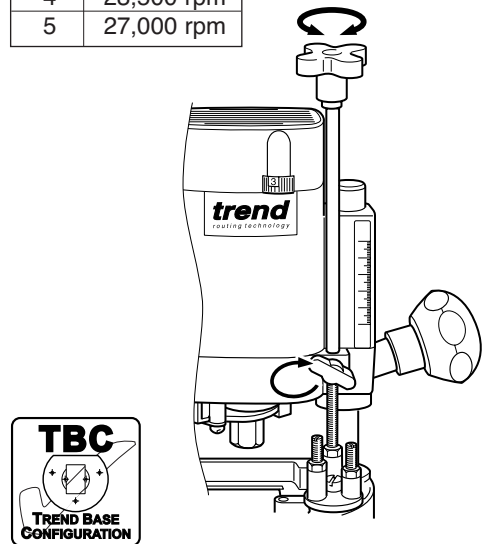

**OPERATION**



**Cutting Direction**



The direction of routing must always be opposite to the cutter's direction of rotation. Otherwise there is a risk of kick-back.

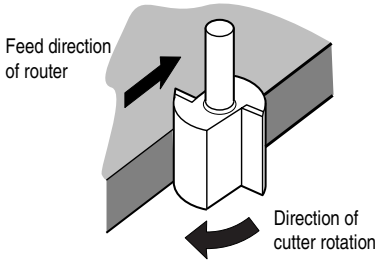

**Feed Direction**

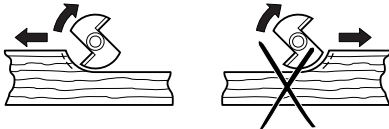

When routing along an edge, the direction of the router travel should be against that of the rotation of the cutter. This will create the correct cutting action and prevent the cutter 'snatching'. It will also pull the router towards the workpiece and hence the side-fence or guide bearing will be less likely to wander from the edge of the workpiece.

**Feed Speed**



The speed at which the cutter is fed into the wood must not be too fast that the motor slows down, or too slow that the cutter leaves burn marks on the face of the wood. Practice judging the speed by listening to the sound of the motor when routing.

**Sequence of plunging**

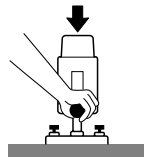

**Step One**

Plunge down and lock the motor carriage, with the plunge locking grip knob.

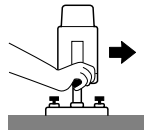

**Step Two**

Carry out the routing operation.

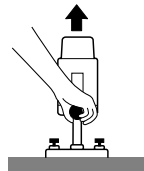

**Step Three**

Release the plunge locking grip knob and the motor carriage returns to the normal position.

**Moulding Natural Timbers**



When edge moulding natural timbers, always mould the end grain first, followed by the long grain. This ensures that if there is 'breakout', this will be removed when the long grain is routed.

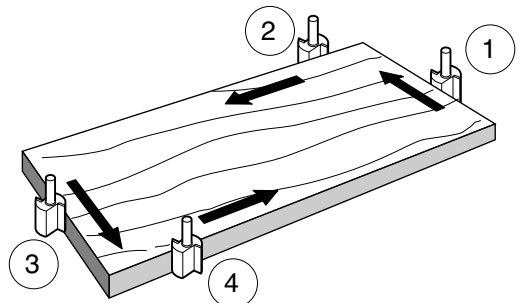

## Side-Fence Routing

The side-fence is used to guide the router when moulding, edge profiling or rebating the edge of the workpiece or when routing grooves and slots in the centre of the workpiece, parallel to the edge.

The edge of the workpiece must be straight and true. The cheeks are adjustable and should be set ideally with a 3–4mm gap each side of the cutter.

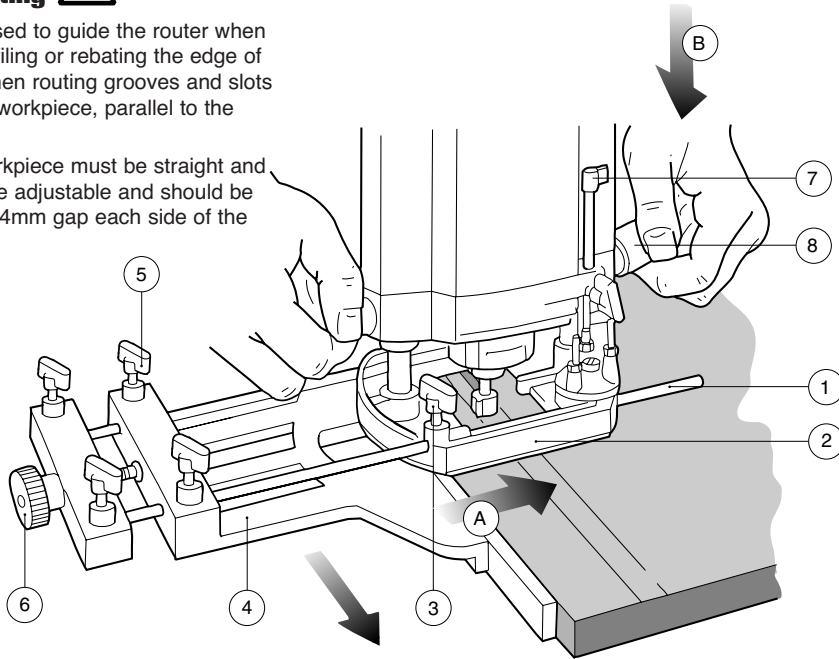

### Fitting and using the Side-Fence

- Make sure the thumb knobs (3) are fully released. Slide the guide rods (1) into the routing base (2) and tighten the thumb knobs (3).
- Adjust the side-fence (4) to the required distance and clamp in place with the thumb knobs (5).
- Then lower the cutter height until the cutter is just above the workpiece.
- Fine adjustments are possible by slackening the thumb knobs (5), adjusting the micro-adjustment knob (6) and securing it again with the thumb knobs (5). One revolution of the micro-adjustment knob (6) equals 1.25mm of side-feed.
- Lower the cutter onto the workpiece and set the cutter height by raising the depth stop (7) the required distance.
- Switch on the router and when the cutter reaches full speed, gently lower the cutter into the workpiece and lock the plunge.

- Feed along the timber, keeping sideways pressure (A) to ensure the side-fence does not wander away from the workpiece edge and downward pressure on the inside hand (B) to prevent the router from tipping.
- When finished, raise the router, secure with the plunge locking grip knob (8) and switch off.

When starting the cut, keep the pressure on the front cheek (C) until the back cheek contacts the workpiece edge.

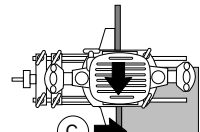

At the end of the cut, keep pressure on the back cheek (D) until the cut is finished. This will prevent the router cutter swinging in at the end of the workpiece and 'nipping' the corner.

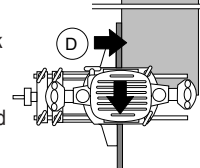

### Using the Guide Bush

The 20mm guide bush (1) is fastened to the router's base from beneath using the two M5 countersunk machine screws (2) supplied.

### Routing with a Template

The guide bush is used in conjunction with a template when the routing operation is repetitive or the workpiece is complex in shape. The template is fixed to the upper surface of the workpiece. A cutter is chosen with a diameter which will pass through the centre of the bush leaving enough clearance. The cutter can be straight or shaped. The router can then be guided around the template so that the shape of the template will be replicated.

### Making the Template

The template is cut from 6mm or 1/4" MDF, plywood or plastic to the shape required. The guide bush offset needs to be allowed for when calculating the shape of the template. The template must be smaller by an amount equal to the difference between the 'outer edge of the guide ring' and the 'outer edge of the cutter'. See below for the offset calculation. The edge of the template must be free of imperfections as these will be replicated in the final workpiece.

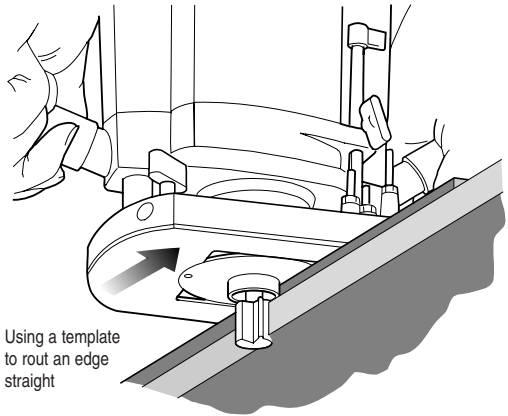
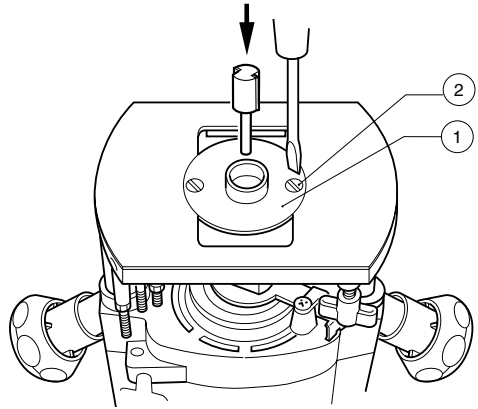

### Calculations for template offset

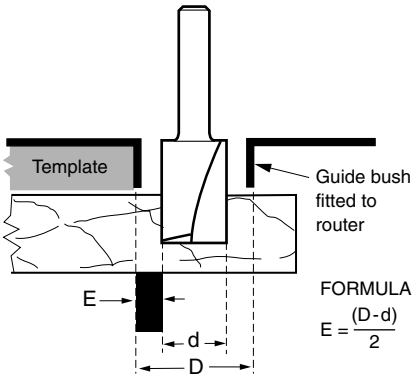

Alternatively it can be used for cutting shapes or making panelling grooves.

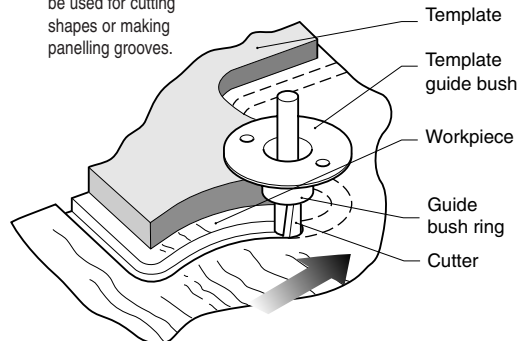

**Beam Trammel Routing** 

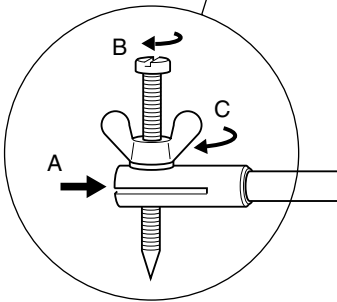
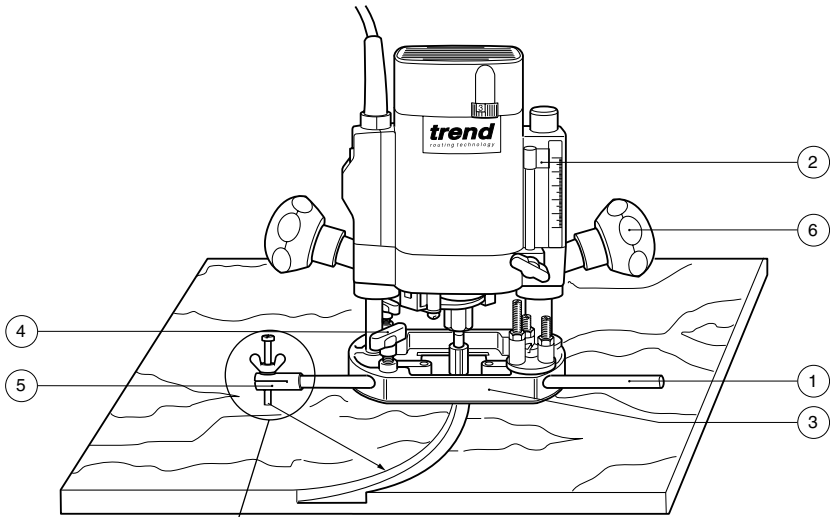

**Fitting the beam trammel attachment**

- Fit the beam trammel attachment (A) to the end of one rod and tighten wing nut (C) securely.
- Height adjustment of the pivot point can be achieved by loosening wing nut (C) and rotating screw (B).
- Once set to the correct height, lock securely wing nut (C).

**Cutting Arcs with the Router** 

- Place the machine on the workpiece.
- Set the cutting depth using the depth stop (2).
- Fasten the fence rod (1) in the routing base (3) with the thumb knob (4).
- Fit on the beam trammel point (5) as shown.
- Measure the radius and fix the point of the beam trammel in position.
- Switch on the machine.
- After releasing the plunge locking knob (6), lower the machine slowly as far as the depth stop and lock it there.
- Cut grooves, rebates etc. at a steady rate of feed, in an anti-clockwise direction. Ensure the beam trammel point does not move.
- When finished, release locking knob to raise the machine.
- Switch off the machine.

**Bearing Guided Cutters**

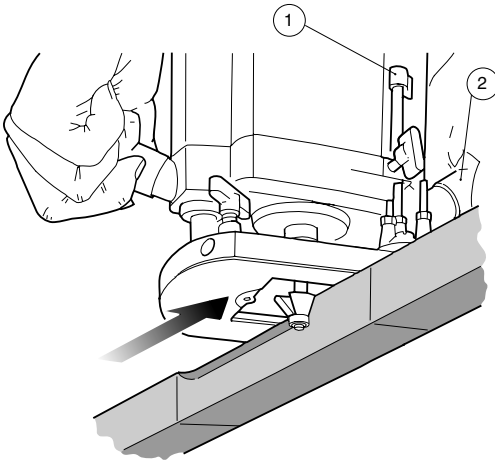

- Fit the bearing guided cutter into the router collet.
- Place router onto the workpiece.
- Set height of cutter using the depth stop (1).
- Switch on the machine.
- After releasing the plunge locking grip knob (2), lower the machine slowly as far as the depth stop.
- With bearing of cutter running along board edge, mould the edge of the workpiece by moving the router in the direction shown.
- A continuous motion should be used to prevent burning of the workpiece. When possible, take a number of passes at increased cutter depths. A light final pass will produce a good finish.
- When complete, retract the carriage by releasing the locking grip knob.
- Switch off the router.

**Ball Bearing Guided Cutters**



Edge profiling and shaping cutters are available with a bearing fitted to the end. This enables shaped or straight workpieces to be routed without the need for a guiding device such as a side-fence or batten.

The edge must be free from imperfections as these will be reflected in the finish of the mould. Often alternative diameters of bearings are offered which will change the shape of the resulting mould.

With certain shapes such as the chamfer cutter below, increasing the depth of cut will produce a larger chamfered edge.

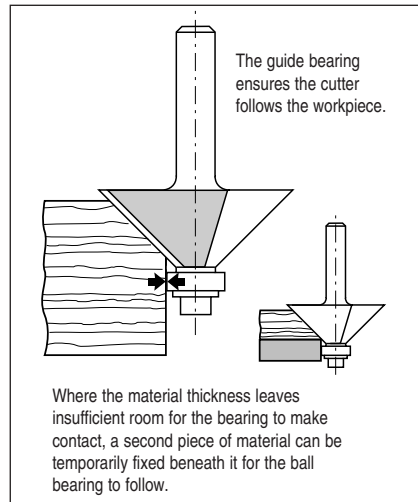

**Keep downward pressure with the inside hand to prevent the router from tipping.**



### Freehand Routing with the Router

The T5 can also be used for signwriting or creative freehand work without any form of guide.

With practice, numbers or name plate designs can be routed freehand. Draw the design or motif on the workpiece and then rout the design, taking shallow passes.

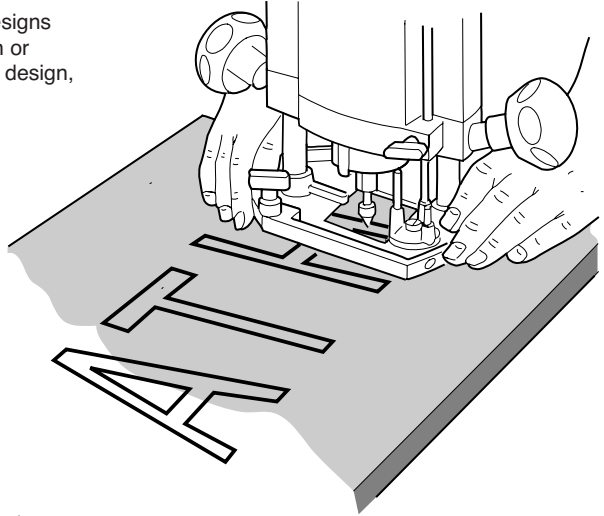
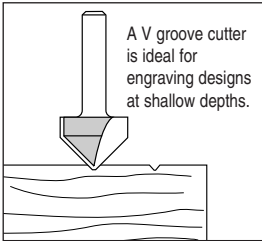

### Batten Routing

Where a side-fence cannot be used, it is also possible to guide the router along a batten clamped across the workpiece (with an overhang at both ends).

Guidance from a batten is similar to that obtained from a side-fence. This method is appropriate if the edge of the workpiece is not straight or is not very smooth or simply the guide rods of the side-fence are too short for the job.

Use the straight edges of the router base and calculate the distance required from the edge of the batten to the cut required. Always check that the clamps do not obstruct the path of the router before starting the cut.

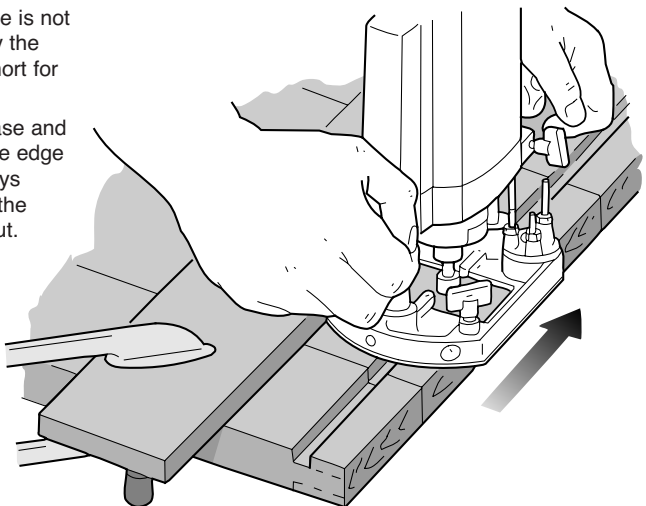

Standard technique is used, and side pressure applied to ensure the router does not wander from the batten.

## MAINTENANCE AND CARE

### Cleaning

- Keep the machine clean at all times. Some maintenance products and solvents may damage the plastic parts, these include products containing Benzene, Trichloroethylene Chloride and Ammonia.
- Never use any caustic agents to clean the plastic parts.

### Changing Brushes



**Ensure machine is isolated from power supply.**



**It is advisable to have the brushes replaced by an authorised Trend Service Agent. The router will also be given a thorough inspection.**

- Undo the single screw (1) in the top of the vent housing. Slide the vent housing (2) off.
- Pull back the spring retaining clip (4). Take care not to bend or distort the coil spring.
- Disconnect the wire (5) and remove the carbon brush (6).
- Insert the new brush and press the connector firmly on to the tag (3). Refit the cover.
- Always use original T5 spare parts.

### Lubrication

- The bearings of the machine need no lubrication, as they are sealed. The two plunge columns on the routing base should be slightly oiled from time to time.
- Keep the cooling vents on the motor housing clean and unobstructed at all times. Blow out any dust and dirt at regular intervals.
- Visually check the carbon brushes. In the event of excessive sparking, they may need changing.
- After about 40 operating hours inspection by a authorised Trend Service Agent is recommended.

## ENVIRONMENTAL PROTECTION

**Recycle raw materials instead of disposing as waste.**

Accessories and packaging should be sorted for environmental-friendly recycling.



Separate collection. This product must not be disposed of with normal household waste.

Local regulations may provide for separate collection of electrical products from the household, at municipal waste sites or by retailer when you purchase a new product.

Please call Trend Technical Support for advice as to how to dispose of unwanted Trend electrical product in an environmentally safe way.

## GUARANTEE

The machine carries a manufacturers guarantee in accordance with the conditions on the enclosed guarantee card.

For the location of your nearest Trend Service Agent, please call Trend Technical Support.

<b>T5 - SPARE PARTS LIST</b>			<b>v8.0 09/2005</b>
<b>No.</b>	<b>Qty.</b>	<b>Desc.</b>	<b>Ref.</b>
1	1	Stator Housing	WP-T5/001
2	1	Top Vent Housing	WP-T5E/002
3	1	Base Complete	WP-T5/003
4	1	Lower Bearing Housing	WP-T5/004
5	1	Spring for Revolving Guide	WP-T5/005
6	1	Ball for Revolving Guide	WP-T5/006
7	1	Machine Screw Socket M6 x 20mm Slot	WP-SCW/49
8	1	Revolving Guide	WP-T5/008
9	3	Nut Hex M5	WP-NUT/05
10	1	Threaded Pin M5 x 30mm Revolving Guide	WP-T5/010
11	7	Thumb Knob M6 Male x 12mm	WP-T5/011
12	1	Spacer Revolving Guide	WP-T5/012
13	1	Threaded Pin M5 x 20mm	WP-T5/013
14	1	Depth Stop	WP-T5/014
15	1	Plunge Knob Grip Knob	WP-T5/015
16	7	Spring 12mm for Thumb Knob	WP-T5/016
17	3	Machine Screw Csk M4 x 10mm Pozi	WP-SCW/48
18	1	Bottom Bearing 35mm x 17mm x 10mm 6003	WP-T5/018
19	2	Screw Self Tapping 4mm x 20mm Torx	WP-T5/019
20	1	Bearing Cover for Top Bearing	WP-T5/020
21	2	Machine Screw Cheese M4 x 89/45mm Pozi	WP-T5/021
23	1	2 Core Cable with Plug 240V UK T5	WP-T5/023
	1	2 Core Cable with Plug 115V UK T5L	WP-T5L/023
	1	2 Core Cable with Plug 230V Euro T5/EURO	WP-T5EURO/023
24	1	Cable Guard	WP-T5/024
25	1	Switch Cover	WP-T5/025
	1	Switch Cover T5MK2	WP-T5/2/025
26	1	Screw Self Tapping 3.5mm x 22mm Torx	WP-T5/026
27	1	Switch 240V T5 & T5/EURO	WP-T5E/027
	1	Switch 115V T5EL	WP-T5EL/027
	1	Switch 240V T5MK2	WP-T5E/2/027
27A	1	Switch Lever Spring T5MK2	WP-T5E/2/027A
27B	1	Switch Lever T5MK2	WP-T5E/2/027B
28	1	Cable Clamp	WP-T5/028
29	1	Field Complete 240V T5E & T5/EURO	WP-T5E/029
	1	Field Complete 115V T5EL	WP-T5EL/029
30	1	Deflector	WP-T5/030
31	1	Armature 240V with Fan T5 & T5/EURO	WP-T5E/031
	1	Armature 115V with Fan T5EL	WP-T5EL/031
32	1	Carbon & Holder 240V T5 & T5/EURO (2 sets)	WP-T5E/032
	1	Carbon & Holder 115V T5EL (2 sets)	WP-T5EL/032
33	2	Brush Clamp	WP-T5/033
34	1	Guide Rods 8mm x 300mm (pair)	ROD/8x300
35	1	Top Bearing 8mm x 22mm x 7mm 6082Z	WP-T5/035
36	1	Slotted Round Nut	WP-T5/036
37	1	Collet Nut <05/2005	CLT/NUT/T5
38	1	Threaded Pin M5 x 40mm Revolving Guide	WP-T5/038

**T5 - SPARE PARTS LIST****v8.0 09/2005**

<b>No.</b>	<b>Qty.</b>	<b>Desc.</b>	<b>Ref.</b>
39	1	Collet 6.5mm (UK & EIRE) <05/2005	CLT/T5/635
	0	Collet 6.0mm <05/2005	CLT/T5/6
	0	Collet 8.0mm (Europe) <05/2005	CLT/T5/8
39A	1	Collet & Nut Set 6.35mm >05/2005	CNS/T5/635
	0	Collet & Nut Set 6.0mm >05/2005	CNS/T5/6
	0	Collet & Nut Set 8.0mm >05/2005	CNS/T5/8
40	1	Spanner 17mm A/F	SPAN/17
41	6	Screw Self Tapping 4mm x 16mm Torx	WP-T5/041
42	2	Locking Washer B4	WP-T5/042
44	1	Beam Trammel for 8mm Rod	BEAM/005
45	1	Guide Bush 20mm Diameter	GB20/B
46	0	Parallel Side Fence Complete with Micro Adjuster	WP-T5/046
47	1	Parallel Side Fence Casting >05/2005	WP-T5/047A
48	1	Micro Adjuster Knurled Knob >05/2005	WP-T5/048A
49	1	Side Fence Cheeks (set) >05/2005	WP-T5/049A
50	1	Phenolic Base Plate Slider	WP-T5/050
51	4	Machine Screw Cheese M5 x 10mm Slot	WP-SCW/50
52	4	Washer 5.3mm x 10mm x 1mm	WP-T5/052
53	1	Scale	WP-T5/053
55	1	Speed Control Circuit Board 240V T5 & T5/EURO	WP-T5E/055
	1	Speed Control Circuit Board 115V T5EL	WP-T5EL/055
56	1	Speed Control Dial	WP-T5E/056
57	1	Insertion Socket	WP-T5/057
58	2	Conductor Lead Switch to Speed Control (Blue x 155mm)	WP-T5/058
60	1	Spring for Spindle Lock	WP-T5/060
61	1	Spindle Lock Body	WP-T5/061
62	1	Spindle Lock Plate	WP-T5/062
63	1	Screw Self Tapping 4mm x 8mm Torx	WP-T5/063
64	1	Washer 20mm x 8mm x 2mm Csk for Column	WP-T5/064
65	1	Machine Screw Csk M5 x 10mm Slot	WP-T5/065
66	1	Plunge Column Spring	WP-T5/066
67	1	Brass Ferrule for Spring	WP-T5/067
68	2	Machine Screw Countersunk M5 x 10mm Slot	WP-SCW/13
69	1	Rubber Sleeve	WP-T5/069
70	1	Lead Field to Speed Control (Red x 90mm)	WP-T5/070
71	1	Lead Field to Speed Control (Red x 120mm)	WP-T5/071
72	1	Lead Brush to Field (Blue x 90mm)	WP-T5/072
73	1	Lead Brush to Field (Blue x 130mm)	WP-T5/073
74	1	Dust Extraction Spout	WP-T5/074
75	1	Grip Knob Direction Arrow	WP-T5/075
76	1	Fixed Grip Knob	WP-T5/076
77	0	Side Fence Complete without Micro Adjuster	WP-T5/077
78	1	Side Fence Stud M8 x 100mm >05/2005	WP-T5/078A
79	1	Side Fence Washer 24mm x 12mm x 1.6mm	WP-T5/079
80	1	Side Fence Half Nut Hex M8	WP-T5/080
81	1	Side Fence Circlip 12mm	WP-T5/081
82	1	Side Fence Micro Adjuster Casting	WP-T5/082
83	1	Fine Height Adjuster T5EK, T5ELK & T5/EURO	FHA/001
84	1	Trigger Lock T5MK2	T5MK2/LOCK
85	1	Manual	MANU/T5

**T5 MK1 - SPARE PARTS DIAGRAM**

v8.0 09/2005

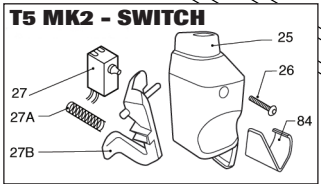
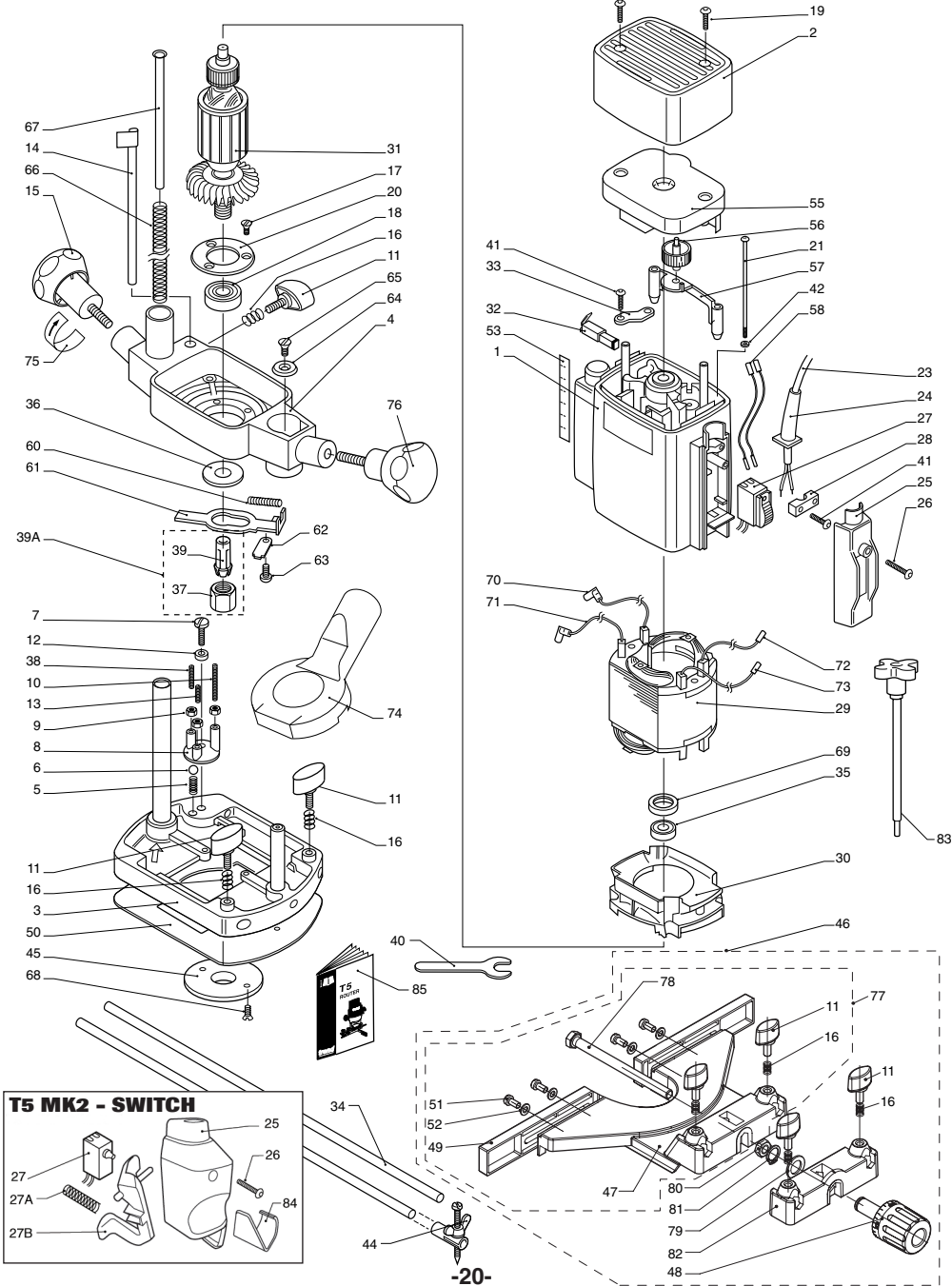

MANU/T5 v8.0



RECYCLABLE

**Trend Machinery & Cutting Tools Ltd.**

Odhams Trading Estate St Albans Road  
Watford WD24 7TR England

**Enquiries:** \_\_\_\_\_ 0800 487363

**Technical Support:** \_\_\_\_\_ 0044 (0) 1923 224681

**Fax:** \_\_\_\_\_ 0044 (0) 1923 236879

**Email:** \_\_\_\_\_ enquiry@trendm.co.uk

**Web:** \_\_\_\_\_ www.trendmachinery.co.uk