



T4

PLUNGE ROUTER



USA

trend[®]
routing technology

Dear Customer

Thank you for purchasing this Trend product, we hope you enjoy many years of creative and productive use.

Please remember to return your guarantee card within 28 days of purchase.

CONTENTS

TECHNICAL DATA	1
SAFETY	2-3
ELECTRICAL SAFETY	4
NOISE / VIBRATION	5
ITEMS ENCLOSED	5
DESCRIPTION OF PARTS	6
ASSEMBLY & ADJUSTMENT	
– Dust Extractor Spout	7
– Switching On & Off	8
– Depth of Cut	8
– Fitting & Removing Bits	9
– Speed Control	10
– Fine Height Adjuster	10
– Fixing Points	10
OPERATION	
– Cutting Direction & Feed Speed	11
– Moulding Natural Timbers	11
– Side-Fence Routing	12
– Template Guide Bush Routing	13
– Carving & Grinding	14
– Bearing Guided Bits	15
– Freehand Routing	16
– Batten Routing	16
MAINTENANCE & CARE	17
ENVIRONMENTAL PROTECTION	17
GUARANTEE	17
SPARE PARTS	
– Spare Parts List	18-19
– Spare Parts Diagram	20

TECHNICAL DATA

Voltage:	110V
Ampage:	6.6A
Power input	1HP
No load speed	11,500-32,000 rpm
Router carriage	2 columns
Router carriage stroke	1½"
Revolver depth stop	3-step, turret stop adjustment with graduation
Collet size	6.35mm (¼") 6mm & 8mm
Bit diameter max.	1⅞"
Weight	7.7lbs

The following symbols are used throughout this manual:



Denotes risk of personal injury, loss of life or damage to the tool in case of non-observance of the instructions in this manual.



Denotes risk of electric shock.



Caution

Carefully read through this entire instruction Manual and the entire router Operator's Manual before using your new T4 Router. Pay close attention to the Safety section and the Safety Symbols. If you use your T4 Router properly and only for what it is intended, you will enjoy years of safe, reliable service.

For Technical Support

Email: technical@trend-usa.com



The operation of any router can result in foreign objects being thrown into your eyes, which can result in severe eye damage. Before beginning power tool operation, always wear safety glasses with side shields and a full face shield when needed. We recommend Wide Vision Safety Mask for use over eye glasses or standard safety glasses with side shields. Always wear eye protection.

SAFETY



WARNING:

Observe the safety regulations in the instruction manual of the power tool to be used. Please read the following instructions carefully. Failure to do so could lead to serious injury. When using electric tools, basic safety precautions, including the following should always be followed to reduce the risk of fire, electric shock and personal injury. Also observe any applicable additional safety rules. Read the following safety instructions before attempting to operate this product.

PLEASE KEEP THESE INSTRUCTIONS IN A SAFE PLACE.

Users must be competent with woodworking equipment before using our products.

IMPORTANT NOTE:

Residual Risk. Although the safety instructions and operating manuals for our tools contain extensive instructions on safe working with power tools, every power tool involves a certain residual risk which cannot be completely excluded by safety mechanisms. Power tools must therefore always be operated with caution!

General

1. Disconnect power tool and attachment from power supply when not in use, before servicing, when making adjustments and when changing accessories such as bits. Ensure switch is in "off" position. Always ensure bit has stopped rotating.
 2. Always mount the power tool, accessory or attachment in conformity with the instructions. Only use attachment and accessories specified in the power tool manual. The tool or attachment should not be modified or used for any application other than that for which it was designed. Do not force tool.
 3. Keep children and visitors away. Do not let children or visitors touch the tool, accessory or attachment. Keep children and visitors away from work area. Make the workshop child proof with padlock and master switch.
 4. Dress properly. Do not wear loose clothing or jewelry, they can be caught in moving parts. Rubber gloves and non-skid footwear is recommended when working outdoors. Wear protective hair covering to contain long hair.
 5. Consider working environment. Do not use the product in the rain or in a damp environment. Keep work area well lit. Do not use power tools near gasoline or flammable liquids. Keep workshop at a comfortable
- temperature so your hands are not cold. Connect machines that are used in the open via a residual current device (RCD) with an actuation current of 30 mA maximum. Use only extension cords that are approved for outdoor use.
6. The accessory or attachment must be kept level and stable at all times.
 7. Keep work area clean. Cluttered workshops and benches can cause injuries. Ensure there is sufficient room to work safely.
 8. Secure idle tools. When not in use, tools should be stored in a dry and high or locked up place, out of reach of children.
 9. For best control and safety use both hands on the power tool and attachment. Keep both hands away from cutting area. Always wait for the spindle and bit to stop rotating before making any adjustments.
 10. Always keep guards in place and in good working order.
 11. Remove any nails, staples and other metal parts from the workpiece.
 12. Maintain tools and bits with care. Keep bits sharp and clean for better and safer performance. Do not use damaged bits. Follow instructions for lubricating and changing accessories. Keep handles dry, clean and free from oil and grease.
 13. Maintain accessories. Do not use damaged accessories. Only use accessories recommended by the manufacturer.
 14. Check damaged parts. Before operation inspect the attachment, the power tool, the cord, extension cord and the plug carefully for signs of damage. Check for alignment of moving parts, binding, breakage, mounting and any other conditions that may effect its operation. Have any damage repaired by an Authorised Service Agent before using the tool or accessory. Protect tools from impact and shock.
 15. Do not use tool if switch does not turn it on or off. Have defective switches replaced by an Authorised Service Agent
 16. Don't over reach. Keep proper footing and balance at all times. Do not use awkward or uncomfortable hand positions.
 17. Don't abuse the cord. Never carry power tool or accessory by cord or pull it to disconnect from the socket. Keep cord from heat, oil and sharp edges. Always trail the power cord away from the work area.
 18. Connect dust extraction equipment. If devices are provided for the connection of dust extraction and collection facilities, ensure these are connected and properly used.
 19. Check all fixing and fastening nuts, bolts and screws on power tool, attachment and cutting tools before use to ensure they are tight and secure. Periodically check when machining over long periods.
 20. Stay alert. Watch what you are doing. Use common sense. Do not operate tools when you are tired, under the influence of drugs or alcohol.
 21. Personal Protective Equipment (PPE) for eye, ear and respiratory protection must be worn. All PPE must meet current legislation.
 22. Do not leave tools running unattended. Do not leave tool until it comes to a complete stop.
 23. Always clamp workpiece being machined securely.
 24. Only use cutting tools for woodworking that meet current safety standards, and any subsequent amendments.
 25. Vibration levels. Hand held power tools produce different vibration levels. You should always refer to the specifications and relevant safety guidelines.

Routing Safety

1. Read and understand instructions supplied with power tool, attachment and bit.
2. Keep hands, hair and clothing clear of the bit.
3. Remove adjusting keys and wrenches. Check to see that keys and adjusting wrenches are removed from the router tool, bit and attachment before turning router on. Make sure bit can rotate freely.
4. Noise. Take appropriate measures for the protection of hearing if the sound pressure of 85dB(A) is exceeded. Routing sound pressure may exceed 85dB(A), so ear protection must be worn.
5. Eye protection. Always wear eye protection in the form of safety goggles, spectacles or visors to protect the eyes.
6. Respiratory protection. Wear a face or dust mask, or powered respirator. Dust masks/filters should be changed regularly.
7. Do not switch router on with the bit touching the workpiece. At the end of the cut, release the router plunge and allow spindle to stop rotating. Never use the spindle lock as a brake

8. The direction of routing must always be opposite to the bit's direction of rotation. Do not back-cut or climb-cut.
9. Check before cutting that there are no obstructions in the path of the router. Ensure there are no obstacles beneath workpiece when cutting full thickness, and that a sacrificial work surface is used.

Router Bit Safety

1. Cutting tools are sharp. Care should be taken when handling them. Do not drop bits or knock them against hard objects. Handle very small diameter bits with extra care. Always return bit to its packaging after use.
2. Always use bits with a shank diameter corresponding to the size of the collet installed in your tool.
3. The maximum speed (n.max) marked on the tool, or in instructions or on packaging shall not be exceeded. Where stated the speed range shall be adhered to. Recommended speeds are shown in the Trend Routing Catalogue and/or website.
4. Always use router bits in a router. Drill and boring bits must not be used in a router. Router bits must only be used for the material cutting application for which they are designed. Do not use on metal or masonry.
5. Never use bits with a diameter exceeding the maximum diameter indicated in the technical data of the powertool or attachment used.
6. Before each use check that the cutting tool is sharp and free from damage. Do not use the cutting tool if it is dull, broken or cracked or if in any other damage is noticeable or suspected.
7. Bits should be kept clean. Resin build up should be removed at regular intervals with Resin Cleaner[®]. The use of a PTFE dry lubricant will reduce resin build up. Do not use PTFE spray on plastic parts.
8. When using stacked tooling (multi-blade, block and groove etc.) on a spindle arbor, ensure that the cutting edges are staggered to each other to reduce the cutting impact.
9. Bit shanks should be inserted into the collet all the way to the line indicated on the shank. This ensures that at least $\frac{3}{4}$ of the shank length is held in the collet. Ensure clamping surfaces are cleaned to remove dirt, grease, oil and water.
10. Observe the correct assembly and fitting instructions in the router instruction manual for fitting the collet, nut and bit.
11. Tool and tool bodies shall be clamped

in such a way that they will not become loose during operation. Care shall be taken when mounting cutting tools to ensure that the clamping is by the shank of the cutting tool and that the cutting edges are not in contact with each other or with the clamping elements.

12. It is advisable to periodically check the collet and collet nut. A damaged, worn or distorted collet and nut can cause vibration and shank damage. Do not over-tighten the collet nut
13. Do not take deep cuts in one pass; take several shallow or light passes to reduce the side load applied to the bit and router. Too deep a cut in one pass can stall the router.
14. In case of excessive vibrations whilst using the router stop immediately and have the eccentricity of the router, router bit and clamping system checked by competent personnel.
15. All fastening screws and nuts should be tightened using the appropriate wrench or key and to the torque value provided by the manufacturer.
16. Extension of the wrench or tightening using hammer blows shall not be permitted.
17. Clamping screws shall be tightened according to instructions provided by the manufacture. Where instructions are not provided, clamping screws shall be tightened in sequence from the centre outwards.

Using Routers In A Fixed Position

1. After work, release the router plunge to protect the bit.
2. Always use a push-stick or push-block when making any cut less than 12" in length or when feeding the last 12" of the cut.
3. The opening around the bit should be reduced to a minimum using suitably sized insert rings in the table and closing the back fence cheeks or fitting a false fence on the back fence.
4. Whenever possible use a work holding device or jig to secure component being machined. Ensure any attachment is securely fitted to the workbench, with table surface at approximately hip height.
5. Use a No-Volt Release Switch. Ensure it is fixed securely, easily accessible and used correctly.
6. In router table (inverted) mode, stand to the front right of the table. The bit will rotate counter-clockwise when viewed from top so the feed direction is from the right (against the rotation of the bit). In overhead mode, stand to the front left of the machine table and

- the feed direction is from the left.
7. Do not reach underneath table or put your hands or fingers at any time in the cutting path while tool is connected to a power supply.
 8. Never thickness timber between the back of the bit and the backfence.

Useful Advice When Routing

1. Judge your feed rate by the sound of the motor. Feed the router at a constant feed rate. Too slow a feed rate will result in burning.
2. Trial cuts should be made on waste material before starting any project.
3. When using some attachments e.g. a router table or dovetail jig, a fine height adjuster is recommended.
4. When using a template guide bush, ensure there is sufficient clearance between bit tip and inside edge of bush and that it cannot come into contact with collet and nut. Ensure bit and guide bush are concentric.

Router Bit Repair/Maintenance

1. Repair of tools is only allowed in accordance with the manufacturers instructions.
2. The design of composite (tipped) tools shall not be changed in process of repair. Composite tools shall be repaired by a competent person i.e. a person of training and experience, who has knowledge of the design requirements and understands the levels of safety to be achieved.
3. Repair shall therefore include, e.g. the use of spare parts which are in accordance with the specification of the original parts provided by the manufacturer.
4. Tolerances which ensure correct clamping shall be maintained.
5. Care shall be taken that regrinding of the cutting edge will not cause weakening of the body and the connection of the cutting edge to the body.

Electrical Safety 

Power Supply

The electric motor has been designed for one voltage only. Always check that the power supply corresponds to the voltage on the rating plate. Machines marked for 230 volt can also be operated from a 220 volt supply.



The T4 is double insulated. Double insulation eliminates the need for the three wire system. Grounded power cord and grounded power supply.

Double insulated tools are equipped with a polarized plug (one blade is wider than the other.) This plug will fit in a polarized outlet only one way. If the plug does not fit fully in the outlet, reverse the plug. If it still does not fit, contact a qualified electrician to install a polarized outlet. Do not change the plug in any way.

The label on your tool may include the following symbols.

- Vvolts
- Hzhertz
- min.....minutes
-  Class II Construction
- Aamperes
- W.....watts
- ~alternating current
- n_o.....no load speed
- .../min.....revolutions or reciprocations per minute



Never connect the live (L) or neutral (N) wires to the ground pin marked E or \perp .

Using an Extension Cord

- If an extension cord is required, use an approved triple core extension cord suitable for the power input of this tool (see technical data).
- When using a cord reel, always unwind the cord completely.
- Also refer to the table below.

Ampere Rating	Wire Size					
	0.0 - 2.0	2.1 - 3.4	3.5 - 5.0	5.1 - 7.0	7.1 - 12.0	12.1 - 16.0
Cord Length						
25'	18	18	18	18	16	14
50'	18	18	18	16	14	12
75'	18	18	16	14	12	10
100'	18	16	14	12	10	
150'	16	14	12	12		
200'	16	14	12	10		
300'	14	12	10			
400'	12	10				
500'	12					
600'	10					

NOISE/VIBRATION

The noise level when working can exceed 85 dB(A).



Wear ear protection!

Level of sound pressure : _____

L_{pa} (sound pressure) 91.1 dB(A)₁

L_{wa} (acoustic power) 104.1 dB(A)₂ _____

Weighted root mean square acceleration value is: _____

3.0 m/s² (hand arm method) _____

ITEMS ENCLOSED

- 1 x Parallel side-fence with rods
- 1 x Collet 6mm
- 1 x Collet 6.35mm (1/4") fitted to machine
- 1 x Collet 8mm
- 1 x Guide bush 5/8" and fixing screws
- 1 x Screw on style guide bush adapter plate
- 1 x Wrench (17mm A/F) for collet nut
- 1 x Wrench (14mm A/F) for spindle (in carving mode)
- 1 x Hex key (4mm A/F) for side-fence
- 1 x Dust extractor spout
- 1 x Instructions
- 1 x Guarantee card

DESCRIPTION OF PARTS

- (A) Plunge locking lever
- (B) Depth stop
- (C) Motor to base locking nut
- (D) Motor housing
- (E) Power cord
- (F) On/Off switch
- (G) Grip knob
- (H) Variable speed control dial
- (I) Collet nut
- (J) Collet spring (fitted behind collet)
- (K) Thumb knob to secure fence rods
- (L) Router base
- (M) Template guide bush dia. 5/8"
- (N) Collet
- (O) Removable fence cheek
- (P) Side-fence rod fixing screw
- (Q) Hex key for side-fence rods
- (R) Side-fence body
- (S) Wrench (14mm A/F) for spindle when in grinder mode
- (T) 3-way turret stop
- (U) Wrench (17mm A/F) for collet nut
- (V) Thumb knob for depth stop
- (W) Fence guide rods dia. 5/16" x 12" long
- (X) Dust spout fixing screw
- (Y) Template guide bush fixing screw
- (Z) Dust spout 1 1/2" dia.
- (AA) Spindle lock
- (AB) Adapter plate for screw on type guide bush

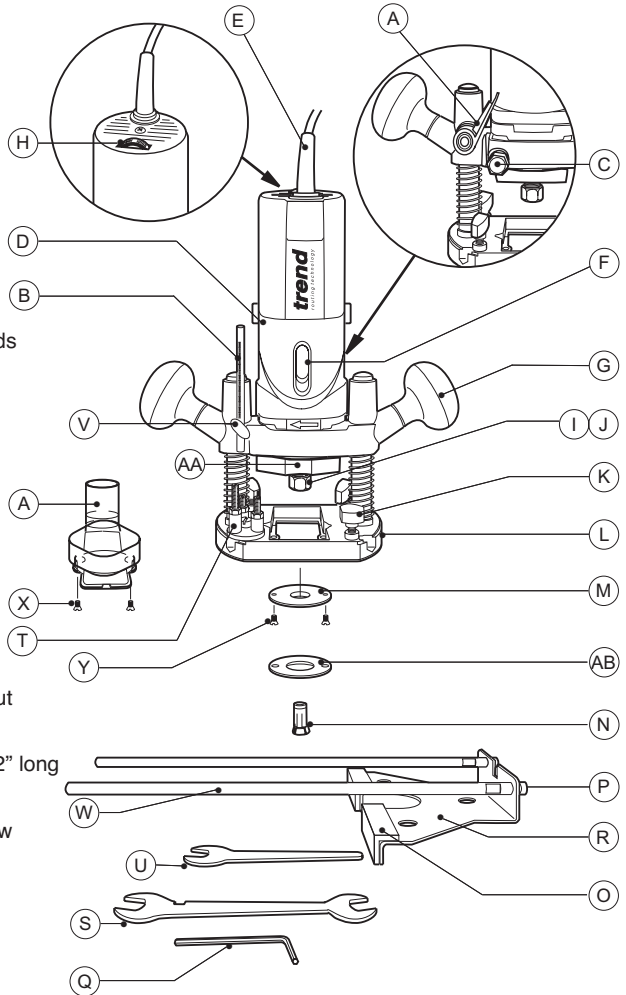

ASSEMBLY & ADJUSTMENT

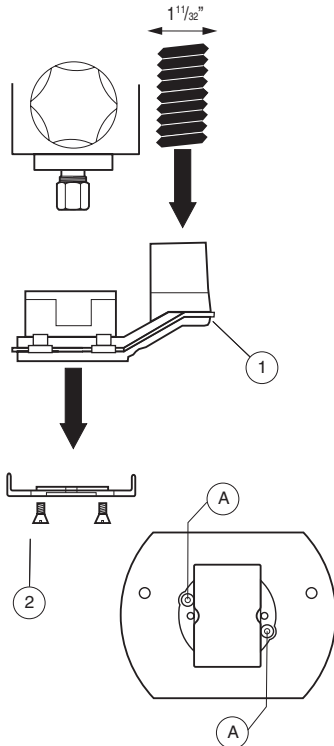

Fitting and Removing the Dust Extractor Spout

- Insert the extractor spout (1) into the base of the router.
- Fit the two countersunk headed screws (2) through holes (A) from beneath and screw-on into the captivated nuts in the spout.
- Dismantle in reverse order.
- The extractor spout is suitable for dust extractors with a hose diameter of 1 1/32".



Whenever possible use the dust extraction spout with a suitable extractor when routing.



In some instances it may be necessary to remove the router from the plunge base to fit the dust spout. Please see page 14.

Switching On & Off

- A slide switch on the front of the motor body is used to turn the router on and off. When fitting the motor unit to the base, ensure that the switch is facing forwards.

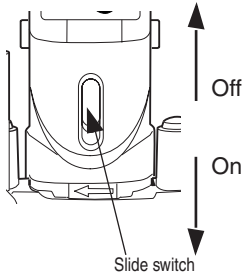

Adjusting the Depth of Cut

- Place the machine on the workpiece.
- Pre-set the 3-way turret stop (1) as required.
- Undo the thumb knob (2) for securing the depth stop (3).
- Undo the plunge locking lever (4).
- Lower the machine slowly until the bit just touches the workpiece and secure it with the plunge locking lever (4).
- Raise the depth stop in accordance with the scale (5) for the depth of cut required and lock in place with the thumb knob (2).

The gap between the depth stop and the turret stop screw determines the depth of cut.

The rotating turret stop screws can be used for pre-setting up to three depths of cut. Their height can be adjusted using a screwdriver (6) and an 8mm A/F wrench (7).



Never make adjustments when the router is running or plugged in. Deep cuts should always be routed in several passes.



Make sure the machine is switched off before connecting it to the power supply!

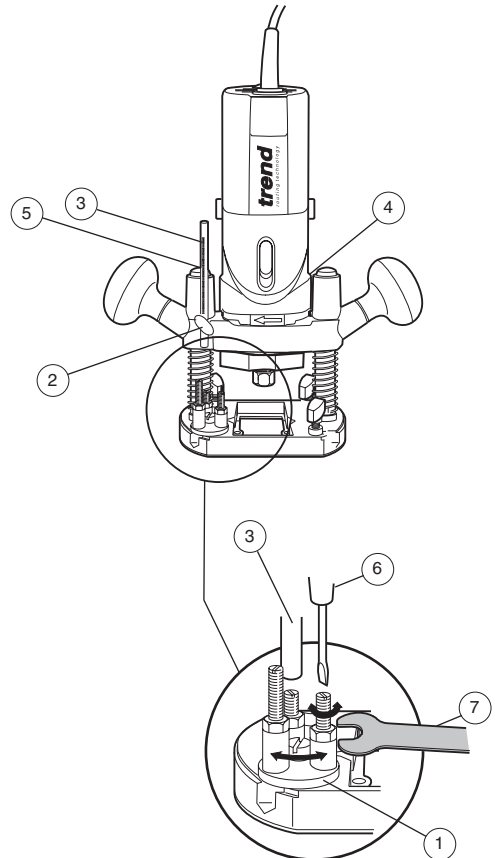

By turning the turret stop, three depth settings can be quickly made.

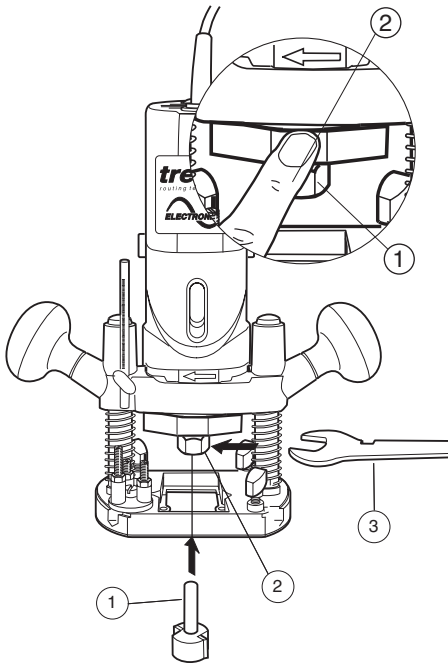

Correct Sequence for Fitting Collet, Nut, Collet Spring and Bit

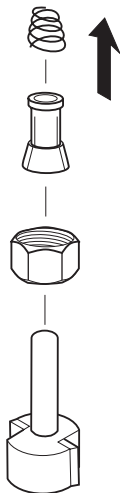

How to Fit and Remove a Router Bit



Fitting Bits

- Insert at least $\frac{3}{4}$ of the shank length of the bit (1) into the collet assembly (2).
- Press the spindle lock (2) until the router spindle is locked (you may need to turn the spindle slightly to engage it).
- Tighten the collet nut with the 17mm A/F wrench (3). Do not use excessive force.

Removing Bits



- Press the spindle lock (2) until the router spindle is locked (you may need to turn the spindle slightly to engage it).
- Undo the collet nut with the 17mm A/F wrench.
- The bit should now slide out.
- Each time you finish using a bit, remove it and store it in a safe place.
- A collet spring is fitted into the spindle behind the collet to allow for easy collet change.



Do not tighten the collet without a bit fitted.

Always use bits with shanks which match the diameter of the collet.

Do not use bits larger than 30mm in diameter.

Electronic Speed Control Dial Setting



The speed is infinitely variable from 11,500 to 32,000 RPM using the electronic speed control dial (1) for uniform cutting results in all types of wood, plastics and in aluminium.

- Turn the electronic speed control dial to the required level. The dial is lettered from 1 to MAX and corresponds to router speeds from 11,500 RPM to 32,000 RPM.



It is recommended that the router speed is set at 24,000 rpm for cutters up to 30mm diameter.

- Generally, use the lower settings for large diameter cutters and the higher settings for small diameter cutters. The correct setting will also depend on the density of the material, depth of cut and feed speed of the router, as severe loss of rpm denotes motor overload. In most cases the slowest speed required for large bits with smaller shank sizes is 18,000 rpm.

Using the Fine Height Adjuster

The optional fine height adjuster (Ref. FHA/009) should be used when fine adjustment is required. This is especially recommended when using our dovetail jig or router table.

- Remove the depth stop and replace it with the fine height adjuster.
- Leave the plunge locking grip knob and the thumb knob loose and thread the end of the fine height adjuster onto the longest screw.
- Set the depth of cut by turning the fine height adjuster handle until the correct height is reached. Then lock the carriage clockwise with the plunge locking grip knob.



Remember to always unlock the carriage by releasing the plunge locking lever when adjusting the height with the fine adjuster.

Fixing Points for Accessories

The router has two M6 threaded holes in its base for fixing the router to a table or various jigs and accessories.

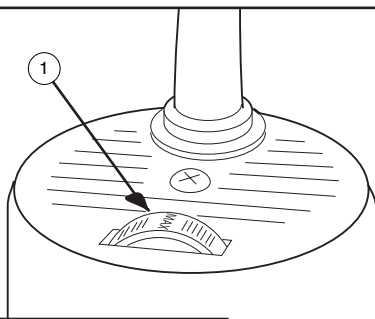

Dial No.	Router Speed
1	11,500 rpm
2	15,000 rpm
3	18,300 rpm
4	21,700 rpm
5	25,000 rpm
6	28,500 rpm
MAX	32,000 rpm

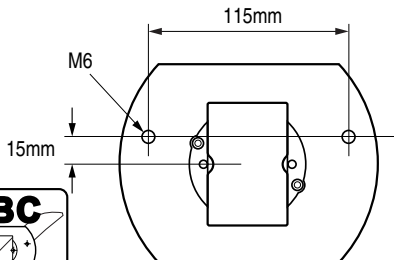
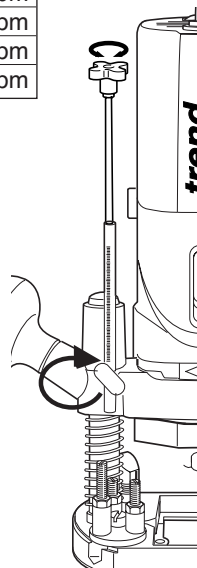

OPERATION



Cutting Direction



The direction of routing must always be opposite to the bit's direction of rotation, otherwise there is a risk of kick-back.

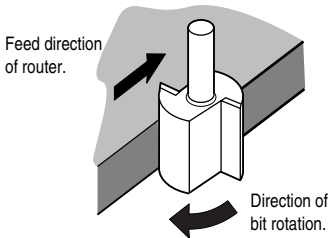

Feed Direction

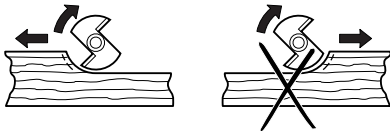

When routing along an edge, the direction of the router travel should be against that of the rotation of the bit. This will create the correct cutting action and prevent the bit 'snatching'. It will also pull the router towards the workpiece and hence the side-fence or guide bearing will be less likely to wander from the edge of the workpiece.

Feed Speed



The speed at which the bit is fed into the wood must not be too fast that the motor slows down, or too slow that the bit leaves burn marks on the face of the wood. Practice judging the speed by listening to the sound of the motor when routing.

Sequence of plunging

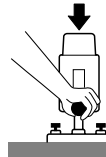

Step One

Plunge down and lock the motor carriage, with the plunge locking lever.

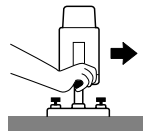

Step Two

Carry out the routing operation.

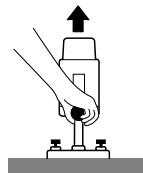

Step Three

Release the plunge locking lever and the motor carriage returns to the normal position.

Moulding Natural Timbers



When edge moulding natural timbers, always mould the end grain first, followed by the long grain. This ensures that if there is 'breakout', this will be removed when the long grain is routed.

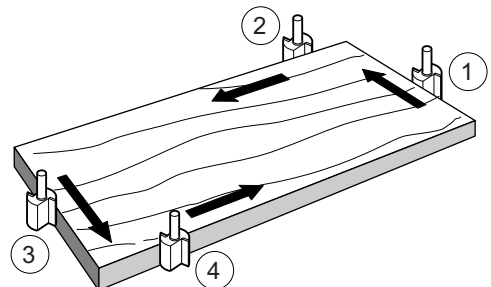

Side-Fence Routing

The side-fence is used to guide the router when moulding, edge profiling or rebating the edge of the workpiece or when routing grooves and slots in the centre of the workpiece, parallel to the edge.

The edge of the workpiece must be straight and true. The cheeks are adjustable and should be set ideally with a 1/8" gap each side of the bit.

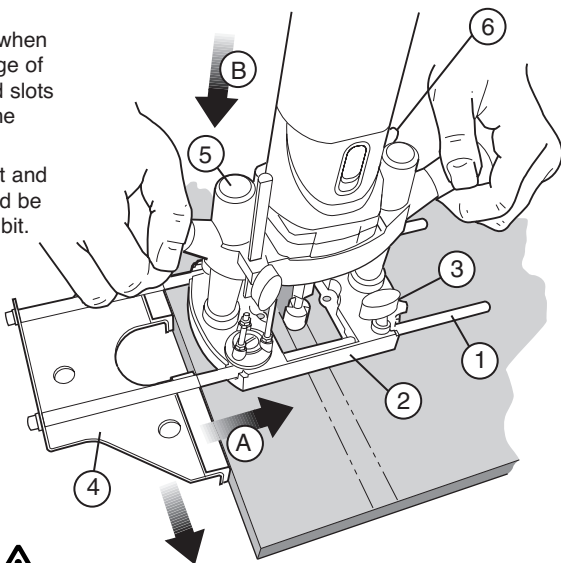

Fitting and using the Side-Fence

- Make sure the thumb knobs (3) are fully released. Slide the guide rods (1) into the router base (2) and tighten the thumb knobs (3).
- Adjust the side-fence (4) to the required distance and clamp in place with the thumb knobs (3).
- Lower the bit height until the bit is just above the workpiece.
- Lower the bit onto the workpiece and set the bit height by raising the depth stop (5) the required distance.
- Switch on the router and when the bit reaches full speed, gently lower the bit into the workpiece and lock the plunge, with the plunge locking lever (6).
- Feed along the timber, keeping sideways pressure (A) to ensure the side-fence does not wander away from the workpiece edge and downward pressure on the inside hand (B) to prevent the router from tipping.
- When finished, raise the bit, secure with the plunge locking lever and switch off.

When starting the cut, keep the pressure on the front cheek (C) until the back cheek contacts the workpiece edge.

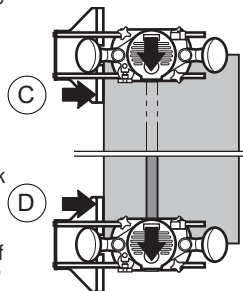

At the end of the cut, keep pressure on the back cheek (D) until the cut is finished. This will prevent the router bit swinging in at the end of the workpiece and 'nipping' the corner.

Using the Guide Bush

The 5/8" guide bush (1), or the adapter plate for screw on style bushes, is fastened to the router's base from beneath using the two M5 countersunk machine screws (2) supplied.

Routing with a Template

The guide bush is used in conjunction with a template when the routing operation is repetitive or the workpiece is complex in shape. The template is fixed to the upper surface of the workpiece. A bit is chosen with a diameter which will pass through the centre of the bush leaving enough clearance. The bit can be straight or shaped. The router can then be guided around the template so that the shape of the template will be replicated.

Making the Template

The template is cut from 1/4" MDF, plywood or plastic to the shape required. The guide bush offset needs to be allowed for when calculating the shape of the template. The template must be smaller by an amount equal to the difference between the 'outer edge of the guide ring' and the 'outer edge of the bit'. See below for the offset calculation. The edge of the template must be free of imperfections as these will be replicated in the final workpiece.

Calculations for template offset

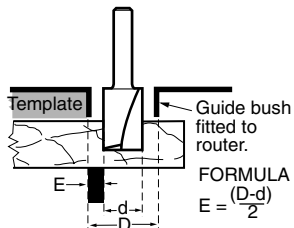

Using a template to rout an edge straight.

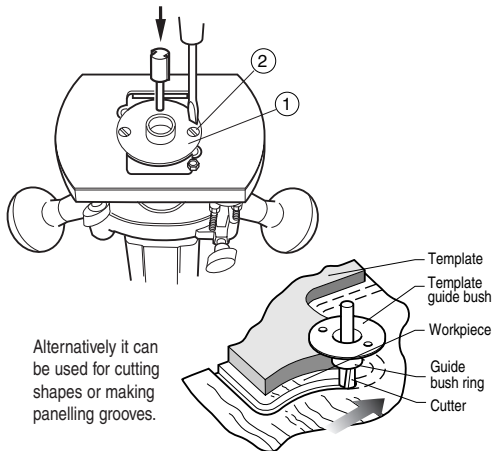
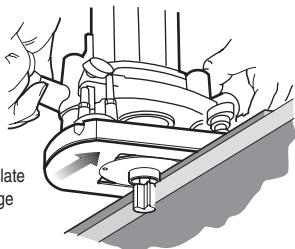

When using a T4 with a Hinge Jig a universal sub-base Ref. UNIBASE is recommended.



In some instances the bit may project below the guide bush, so ensure a router stand block is used.

Making a Router Stand Block

When using a guide bush a useful aid is a router stand block. This is simply a piece of scrap timber with a hole large enough to take the protruding guide bush and bit. This will allow the router to stand up safely between operations.

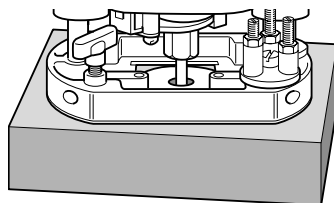
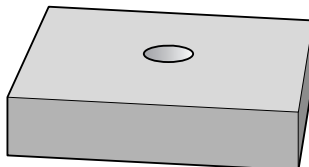

Carving and Grinding

Carving and grinding applications can be carried out with the router removed from its plunge base. When using the router in this way, only use multi flute carving, engraving, or de-burring rasps and burrs.



Never use high speed router bits for carving operations.

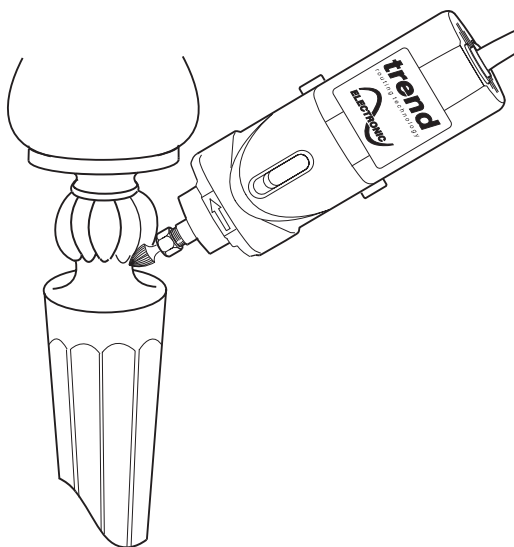

Always unplug the machine from the power supply before separating the router from its plunge base.

Removing the Router from the Plunge Base

- Never separate the router from the base while a bit is fitted in the collet. Always disconnect the router from the power supply before separating the router from the base.
- Remove collet nut, collet and spring.
- Use the 14mm open ended wrench (1) to release the clamping nut (2) on the base. Slacken the nut off until the motor unit slides out of the base (3).
- Refit spring, collet and collet nut.
- To change bits the 14mm A/F wrench and 17mm A/F wrench are used because the spindle lock will be disengage.
- When re-fitting the motor unit, ensure that the switch is facing the front of the router so that it is accessible when plunge routing.
- Ensure that the clamping nut is re-tightened before using the router for normal plunge cutting operations.

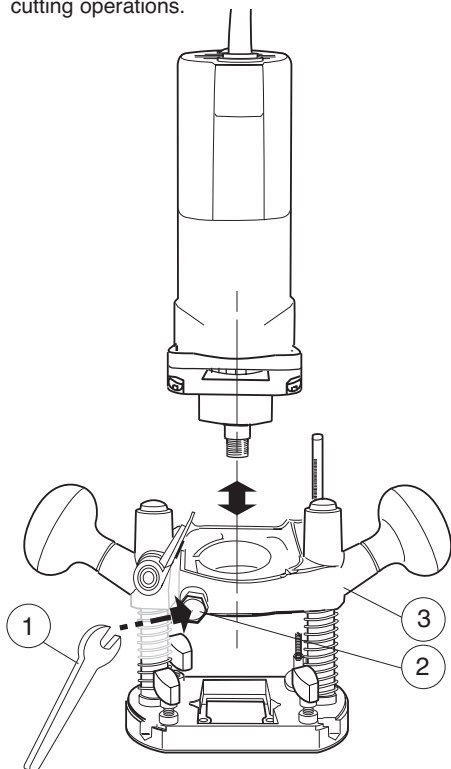

Bearing Guided Bits

Edge profiling and shaping bits are available with a bearing fitted to the end. This enables shaped or straight workpieces to be routed without the need for a guiding device such as a side-fence or batten.

The edge must be free from imperfections as these will be reflected in the finish of the mould. Often alternative diameters of bearings are offered which will change the shape of the resulting mould.

With certain shapes such as the chamfer bit below, increasing the depth of cut will produce a larger chamfered edge.

- Fit the bearing guided bit into the router collet.
- Place router onto the workpiece.
- Set height of bit using the depth stop (1).
- Switch on the machine.
- After releasing the plunge locking lever (2), lower the machine slowly as far as the depth stop.
- With bearing of bit running along board edge, mould the edge of the workpiece by moving the router in the direction shown.
- A continuous motion should be used to prevent burning of the workpiece. When possible, take a number of passes at increased bit depths. A light final pass will produce a good finish.
- When complete, retract the carriage by releasing the locking grip knob.
- Switch off the router.

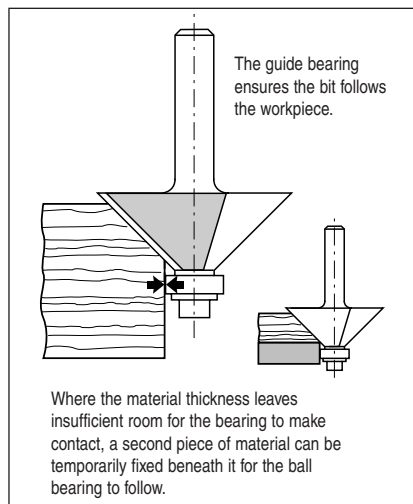
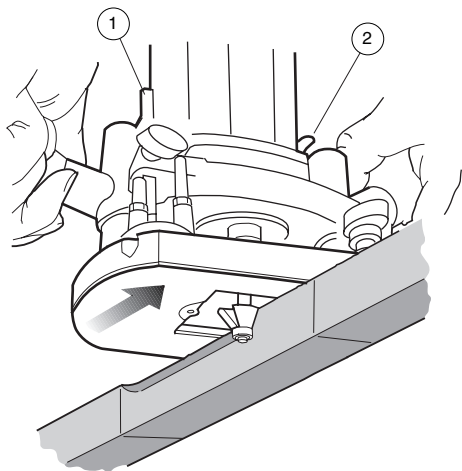

Keep downward pressure with the inside hand to prevent the router from tipping.

Freehand Routing with the Router

The T4 can also be used for signwriting or creative freehand work without any form of guide.

With practice, numbers or name plate designs can be routed freehand. Draw the design or motif on the workpiece and then rout the design, taking shallow passes.

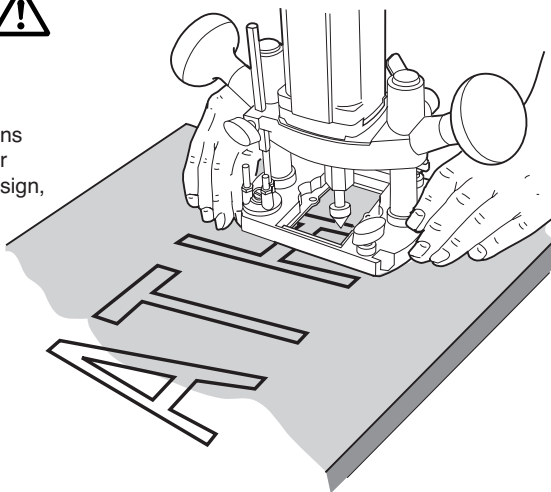
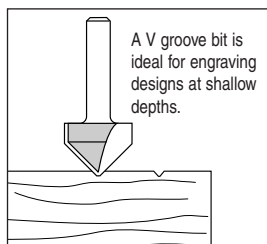

Batten Routing

Where a side-fence cannot be used, it is also possible to guide the router along a batten clamped across the workpiece (with an overhang at both ends).

Guidance from a batten is similar to that obtained from a side-fence. This method is appropriate if the edge of the workpiece is not straight or is not very smooth or simply the guide rods of the side-fence are too short for the job.

Use the straight edges of the router base and calculate the distance required from the edge of the batten to the cut required. Always check that the clamps do not obstruct the path of the router before starting the cut.

The Trend clamp guides have integral clamping mechanism for quick & accurate guiding of the router.

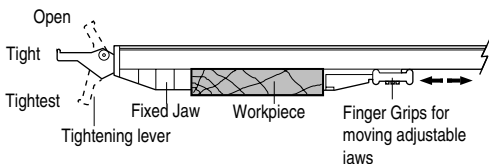

Standard technique is used, and side pressure applied to ensure the router does not wander from the batten.

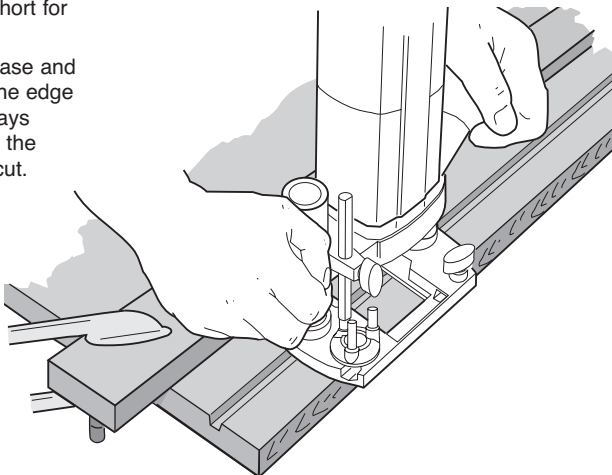

MAINTENANCE AND CARE

Cleaning

- Keep the machine clean at all times. Some maintenance products and solvents may damage the plastic parts, these include products containing Benzene, Trichloroethylene Chloride and Ammonia.
- Never use any caustic agents to clean the plastic parts.

Changing Brushes



Ensure machine is isolated from power supply.

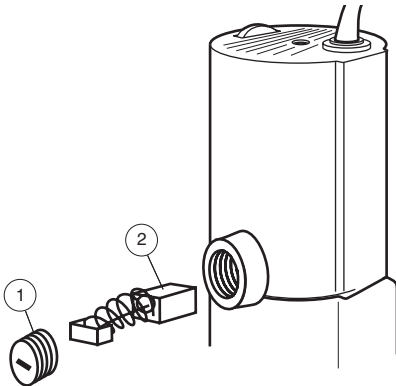

- Undo brush cap (1) using flat head screwdriver.
- Remove brush (2).
- Insert new brush ensuring brush body is correct orientation for aperture.
- Refit brush cap (1) and tighten.
- Repeat for other brush.
- Always use original T4 spare parts.



It is advisable to have the brushes replaced by an authorized Trend Service Agent. The router will also be given a thorough inspection.

Lubrication

- The bearings of the machine need no lubrication, as they are sealed. The two plunge columns on the routing base should be slightly oiled from time to time.
- Keep the cooling vents on the motor housing clean and unobstructed at all times. Blow out any dust and dirt at regular intervals.
- Visually check the carbon brushes. In the event of excessive sparking, they may need changing.
- After about 40 operating hours inspection by a authorised Trend service agent is recommended.

ENVIRONMENTAL PROTECTION

Recycle raw materials instead of disposing as waste.

Accessories and packaging should be sorted for environmental-friendly recycling.



Separate collection. This product must not be disposed of with normal household waste.

Local regulations may provide for separate collection of electrical products from the household, at municipal waste sites or by retailer when you purchase a new product.

GUARANTEE

The machine carries a manufacturers guarantee in accordance with the conditions on the enclosed guarantee card.

T4 USA - SPARE PARTS LIST			v2.0 08/2007
No.	Qty.	Desc.	Ref.
1	1	Stator Housing	WP-T4/001
2	1	Top Vent Housing	WP-T4/002
3	1	Base	WP-T4/003
4	1	Spring Washer 4mm	WP-T4/004
5	2	Washer 4mm x 7mm x 0.8mm	WP-T4/005
6	1	Cord Guard	WP-T4/006
7	1	Speed Control Circuit Board 110V USA	WP-T4ELU/007
8	2	Carbon Brush Cover	WP-T4/008
9	-	-	-
10	1	Carbon Brush 110V (1 pair) USA	WP-T4ELU/010
11	2	Carbon Brush Holder	WP-T4/011
12	2	Spring Washer 5mm	WP-WASH/29
13	2	Column End Cap	WP-T4/013
14	1	Plunge Locking Screw LH	WP-T4/014
15	1	Cord Clamp	WP-T4/015
16	1	Screw Self Tapping Pan 4mm x 12mm Pozi	WP-T4/016
17	1	Switch 110V USA	WP-T4ELU/017
18	1	Push Rod	WP-T4/018
19	1	On / Off Lever	WP-T4/019
20	-	-	-
21	1	2 Core Cord with Plug 110V USA	WP-T4LU/021
22	1	Field 110V USA	WP-T4ELU/022
23	1	Baffle	WP-T4/023
24	2	Machine Screw Pan M4 x 63mm Pozi	WP-T4/024
25	1	Top Bearing 7mm x 22mm x 7mm 608ZZ	WP-T4/025
26	1	Armature 110V with Fan USA	WP-T4ELU/026
27	1	Lower Bearing Housing	WP-T4/027
28	1	Lower Bearing 17mm x 35mm x 10mm 6003ZZ	WP-T4/028
29	1	Screw Self Tapping Pan 4mm x 14mm Pozi	WP-T4/029
30	1	Collar Left Hand Threaded	WP-T4/030
31	2	Machine Screw Pan M6 x 55mm Pozi	WP-T4/031
32	1	Bearing Lock Plate	WP-T4/032
33	1	Collet Spring	WP-T4/033
34	1	Collet 6.35mm (1/4")	CLT/T4/635
	1	Collet 6mm	CLT/T4/6
	1	Collet 8mm	CLT/T4/8
35	1	Collet Nut	CLT/NUT/T4
36	1	Depth Stop	WP-T4/036
37	1	Middle Frame	WP-T4/037
38	1	Thumb Knob	WP-T4/038
39	1	Spring 8mm	WP-T4/039
40	1	Base Housing Lock Nut	WP-T4/040
41	1	Bolt Hex M6 x 48mm	WP-T4/041
42	1	Circlip 17mm	WP-T4/042
43	1	Plunge Lock Lever	WP-T4/043
44	1	Lower Housing Clamp Spacer	WP-T4/044

T4 USA - SPARE PARTS LIST**v2.0 08/2007**

No.	Qty.	Desc.	Ref.
45	1	Plunge lever Torsion Spring 1/2" Dia	WP-T4/045
46	2	Grip Knob	WP-T4/046
47	2	Plunge Spring	WP-T4/047
48	2	Plunge Column	WP-T4/048
49	2	Machine Screw Socket M5 x 12mm	WP-SCW/12
50	1	Dust Extraction Spout Upper Housing	WP-T4/050
51	1	Threaded Pin M5 x 25mm	WP-T4/051
52	3	Nut Hex M5	WP-NUT/05
53	1	Threaded Pin M5 x 35mm	WP-T4/053
54	1	Threaded Pin M5 x 15mm	WP-T4/054
55	1	Stepped Machine Screw M6	WP-T4/055
56	1	Revolving Turret	WP-T4/056
57	1	Ball for Revolving Turret	WP-T4/057
58	1	Spring for Revolving Turret	WP-T4/058
59	1	Set Screw M4 x 5mm slot	WP-T4/059
60	2	Set Screw M6 x 8mm	WP-T4/060A
61	1	Plastic Base Slider	WP-T4/061
62	1	Spring Washer Revolving Guide	WP-T4/062
63	2	Machine Screw Csk M5 x 12mm Slot	WP-SCW/11
64	2	Machine Screw Csk M5 x 8mm Slot	WP-SCW/09
65	1	Guide Rod 5/16" x 12" (pair)	WP-T4/065
66	4	Machine Screw Csk M4 x 6mm Pozi	WP-SCW/66
67	1	Side Fence Cheeks (pair)	WP-T4/067
68	1	Parallel Side Fence Body	WP-T4/068
69	1	Wrench Special 17mm A/F	WP-T4/069
70	1	Machine Screw Pan M4 x 12mm Pozi	WP-T4/070
71	1	Wrench 14mm A/F	WP-SPAN/14P
72	1	Hex Key 4mm A/F	WP-AP/04
73	3	Machine Screw Csk M4 x 18mm Pozi	WP-T4/073
74	2	Washer 6mm x 11mm x 0.8mm	WP-T4/074
75	2	Spring Washer 6mm	WP-WASH/30
76	1	Spindle Lock Housing	WP-T4/076
77	1	Spindle Lock Bracket	WP-T4/077
78	1	Spindle Lock Button	WP-T4/078
79	1	Spindle Lock Plate	WP-T4/079
80	1	Spring for Spindle Lock	WP-T4/080
81	1	Dust Spout Lower Housing	WP-T4/081
82	1	Switch Base	WP-T4/082
83	-	-	-
84	1	Machine Screw Pan M4 x 14mm Pozi	WP-T4/084
85	1	Screw Self Tapping Pan 4mm x 20mm	WP-T4/085
86	1	Depth Stop Knob	WP-T4/086
87	1	Guide Bush 5/8"	GB16/B
88	1	Adapter for Screw on Guide Bush	T3/GBS/USA
89	1	Manual	MANU/T4/USA

T4 USA - SPARE PARTS DIAGRAM

v2.0 08/2007

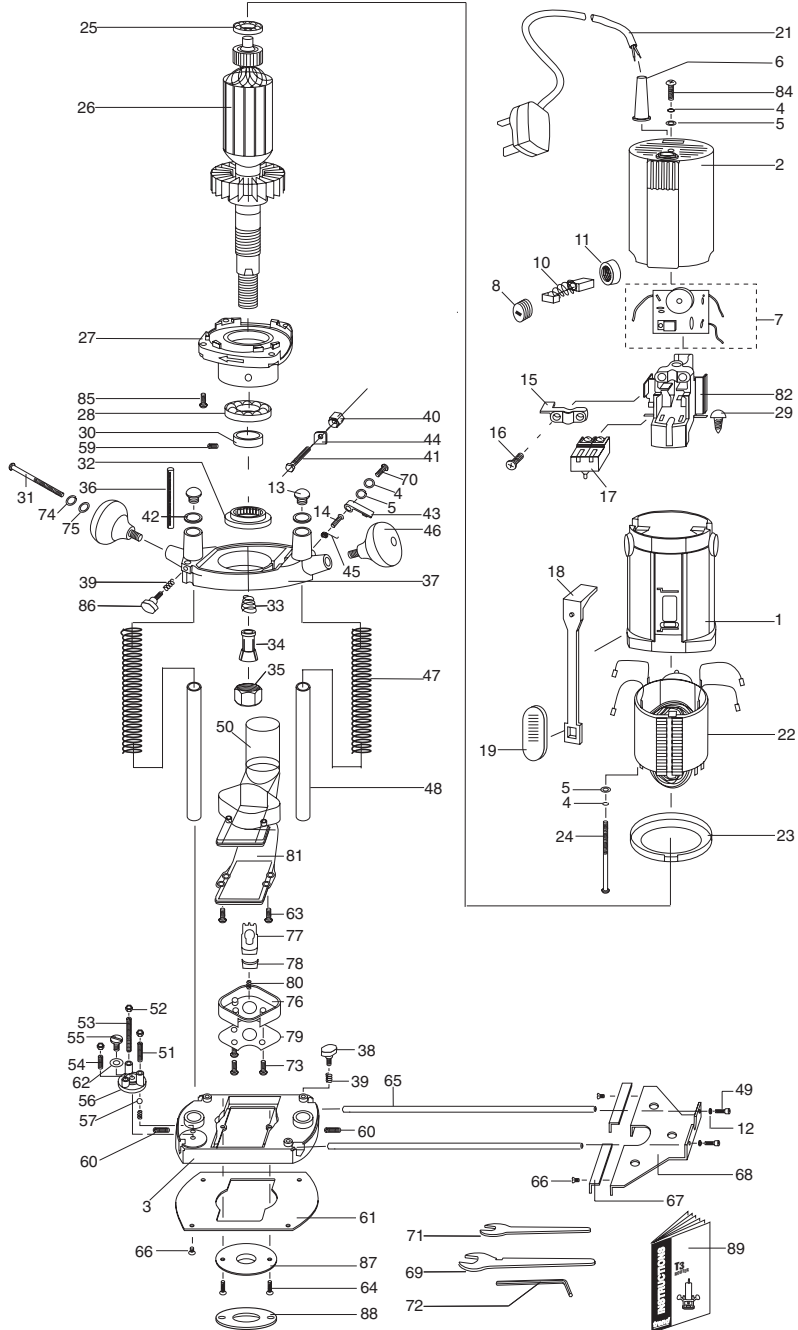

MANU/T4/USA v2.0



RECYCLABLE

Trend Routing Technology Inc.

Technical Support: __0044(0)1923 224681

Email: _____technical@trend-usa.com

Web: _____www.trend-usa.com

© Copyright Trend 2007. No part of this publication may be reproduced, stored or transmitted in any form without prior permission. Our policy of continuous improvement means that specifications may change without notice. Trend Routing Technologies Inc. cannot be held liable for any material rendered unusable or any form of consequential loss. E&OE

® All trademarks acknowledged.