



## T11 Clamp Guide System Accessory Kit T11/CGS/KIT

Please  
read carefully  
before use

### T11 CLAMP GUIDE ACCESSORY KIT REF. T11/CGS/KIT

Thank you for purchasing this Trend product which should give lasting performance if used in accordance with these instructions.

The following symbols are used throughout these instructions.



Denotes risk of personal injury, loss of life or damage to the tool in case of non-observance of the instructions.



Refer to the instruction manual of your power tool.

This unit must not be put into service until it has been established that the power tool to be connected to this unit is in compliance with 98/37/EC (identified by the CE marking on the power tool).

### INTENDED USE

This accessory is intended to be used with a T11 plunge router and a Clamp Guide System clamp to allow parallel grooves to be routed in man-made boards and natural timber with a suitable cutter fitted.

### SAFETY

Please read and understand the safety points at the end of this instruction as well as the power tool instructions before use.

### ITEMS REQUIRED

- T11 router
- Clamp Guide System clamp

### ITEMS ENCLOSED & DESCRIPTION OF PARTS

- A. Centre block **x1**
- B. Nylon guide **x1**
- C. Guide rod 8mm **x2**
- D. Thumb knob M6 **x2**
- E. Thumb knob anti-vibration spring **x2**
- F. Router fixing screw **x2**
- G. Hex key 4mm **x1**
- H. Instructions **x1**

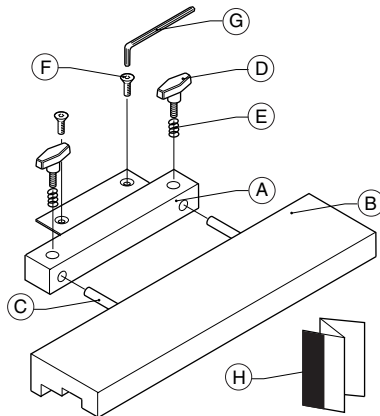

### ENVIRONMENTAL PROTECTION

Recycle raw materials instead of disposing as waste.

Packaging should be sorted for environmental-friendly recycling.

The product and its accessories at the end of its life should be sorted for environmental-friendly recycling.

### GUARANTEE

All Trend products guaranteed against any defects in either workmanship or material, except products that have been damaged due to improper user or maintenance.

© Trend Machinery & Cutting Tools Ltd. 2005 E&OE  
© All trademarks acknowledged

### Trend Machinery & Cutting Tools Ltd.

Odhams Trading Estate St Albans Road  
Watford WD24 7TR England

Enquiries: \_\_\_\_\_ 0800 487 363

Technical Support: \_\_\_\_\_ 01923 224681

Fax: \_\_\_\_\_ 01923 236879

Email: \_\_\_\_\_ enquiry@trendm.co.uk

Web: \_\_\_\_\_ www.trendmachinery.co.uk



RS 28982  
Stockholding  
& Supply



RECYCLABLE

**trend**<sup>®</sup>  
routing technology

INST/T11/CGSK v1.0

## ASSEMBLY



### Isolate router from power supply before fitting the accessory kit.

Locate the centre block bracket over the two tapped holes in the upper section of the T11 router base. Secure the bracket using the two machine screws & hex key.

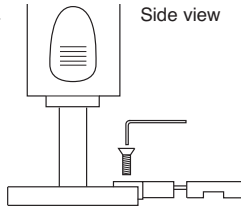

## OPERATION



Slide the centre block and nylon guide together so they touch and then open out to about 5mm. Tighten the thumb knobs to lock the assembly together.

Measure and mark position for the slot or groove. Mark second line 115mm away from this line, this is the offset. Position clamp guide system clamp so that inside edge of the clamp is on the 115mm offset line.

Side view

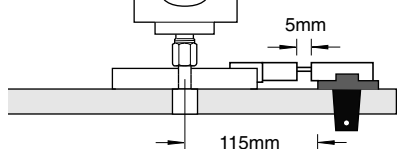

Use a square to square up the Clamp Guide System clamp on the component. Secure clamp onto component.

Place the router with the accessory fitted so that the nylon block sits over the centre T slot of the clamp guide system. Set the cutter depth, by plunging down until cutter touches work piece, lock plunge and the set cutter height on depth scale. Release plunge slightly to raise cutter by about 1mm.

Loosen the thumb knobs and adjust router position in or out so that the cutter edge is correct to cut line. The accessory has a maximum of 12mm adjustment. Once correct position is obtained lock thumb knobs. Release plunge. Switch on router, plunge down and move router assembly along clamp to the required groove length. At the end of the cut, release plunge and switch off router.

Top view

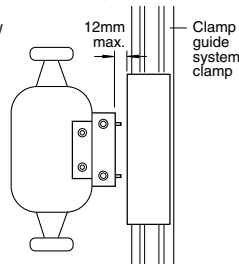

Ensure the guide is not clamped onto the waste piece. The material being cut will need to be supported and clamped securely.

If the slot needs to be made wider, isolate router, undo the two thumb knobs and pull the centre block and nylon guide apart by the required amount, then retighten the thumb knobs.

## SPARE PARTS

Item	Qty	Desc.	Ref. (1 off)
A	1	Centre block	WP-T11/CGS/1
B	1	Nylon guide	WP-T11/CGS/2
D	2	Thumb knob M6 x 15mm	WP-KNOB/18
E	2	Thumb knob anti-vibration spring	WP-SPR/C/01
F	2	Machine screw csk M6 x 12mm socket	WP-SCW/18
G	1	Hex key 4mm A/F	WP-AP/04
H	1	Instructions	INST/T11/CGSK

## MAINTENANCE

The accessory has been designed to operate over a long period of time with minimum of maintenance. Continual satisfactory operation depends upon proper tool care and regular cleaning.

### Cleaning

- Keep the grooves, threads and rods clear of sawdust and resin build up.
- Regularly clean with a soft cloth.

### Lubrication

- This accessory requires no additional lubrication.

## Safety Points

1. Always wear eye protection such as goggles, ear protection and use effective respiratory protection.
2. Before making adjustments to the power tool, like changing the cutter or blade, make sure the power is isolated correctly.
3. Before re-connecting to the mains supply, make sure the power switch on the power tool is in the 'off' position.
4. Do not switch on the power tool with the cutting tool in contact with the workpiece.
5. Before making adjustments always allow the cutting tool to stop rotating.
6. When using power tools keep your hands, hair and clothing clear of the cutting tool.
7. Make sure you follow the instructions which came with your power tool.
8. Ensure all visors, guards and dust extraction are fitted.
9. Trial cuts should be made in waste material before starting any project.

Our policy of continuous improvements mean that specifications may change without notice. Trend Machinery & Cutting Tools Ltd cannot be held liable for any material rendered unusable, or for any form of consequential loss.