



T10 & T11



trend[®]
routing technology

Dear Customer

Thank you for purchasing this Trend product, we hope you enjoy many years of creative and productive use.

Please remember to return your guarantee card within 28 days of purchase.

CONTENTS

TECHNICAL DATA	1
SAFETY	2-3
ELECTRICAL SAFETY	4
MANUFACTURERS DECLARATION	5
ITEMS ENCLOSED	5
DESCRIPTION OF PARTS	6-7
ASSEMBLY & ADJUSTMENT	
– Switching On & Off	8
– Depth of Cut	8
– Fitting & Removing Cutters	9
– Speed Control	10
– Fixing Points for Accessories	10
T10	
– Dust Extraction Spout	11
– Fine Height Adjuster Accessory	11
T10 & T11	
– Template Guide Bush	12
T11	
– Dust Extraction Spout	13
– Fine Height Adjuster	14
– Accessories	15
OPERATION	
– Cutting Direction & Feed Speed	16
– Side-fence Routing	17
– Template Guide Bush Routing	18
– Beam Trammel Routing Accessory	19
– Bearing Guided Cutters	20
– Freehand Routing & Batten Routing	21
MAINTENANCE & CARE	22
ENVIRONMENTAL PROTECTION	22
GUARANTEE	22
SPARE PARTS	
– Spare Parts List	23-26
– Spare Parts Diagram	27



If you require further safety advice, technical information or spare parts, please call Trend Technical Support or visit www.trend-uk.com

TECHNICAL DATA

Voltage:	UK & Eire	230V
	UK & Eire	115V
	Europe	230V
Power input		2000W
Power output		1400W
No load speed (min.)		8,000-20,000 rpm
Router carriage		2 columns
Router carriage stroke		80mm
Revolver depth stop		3-step, turret stop adjustment with graduation
Collet size:	UK & Eire	1/2 inch (12.7mm)
	Europe	12mm
Cutter diameter, max.	T10	50mm
	T11	70mm
Weight		6.3kg
Fuse:	UK & Eire	230V 13A in plug
	UK & Eire	110V 32A in mains
	Europe	230V 10A in mains

The following symbols are used throughout this manual:



Denotes risk of personal injury, loss of life or damage to the tool in case of non-observance of the instructions in this manual.



Denotes risk of electric shock.

For 115 Volt

The 115V router is not supplied with a plug.

We recommend a 32A BS4343 110V plug is used. Minimum generator or transformer requirement 3 kVA continuous with a 32A BS4343 110V socket outlet.

The 115V router cannot be used with a 115V No-Volt Release Switch.

INTENDED USE

The router is intended for routing grooves, edges, profiles and slots as well as copy routing in wood, wood based products and plastic. At reduced speed with the appropriate router cutter fitted non-ferrous alloys can also be routed.

SAFETY



WARNING:

Observe the safety regulations in the instruction manual of the power tool to be used. Please read the following instructions carefully. Failure to do so could lead to serious injury. When using electric tools, basic safety precautions, including the following should always be followed to reduce the risk of fire, electric shock and personal injury. Also observe any applicable additional safety rules. Read the following safety instructions before attempting to operate this product.

PLEASE KEEP THESE INSTRUCTIONS IN A SAFE PLACE.

The attention of UK users is drawn to The Provision and Use of Work Equipment Regulations 1998, and any subsequent amendments.

Users should also read the HSE/HSC Safe Use of Woodworking Machinery Approved Code of Practice and Guidance Document and any amendments.

Users must be competent with woodworking equipment before using our products.

IMPORTANT NOTE:

Residual Risk. Although the safety instructions and operating manuals for our tools contain extensive instructions on safe working with power tools, every power tool involves a certain residual risk which cannot be completely excluded by safety mechanisms. Power tools must therefore always be operated with caution!

General

1. Disconnect power tool and attachment from power supply when not in use, before servicing, when making adjustments and when changing accessories such as cutters. Ensure switch is in "off" position. Always ensure cutter has stopped rotating.
2. Always mount the power tool, accessory or attachment in conformity with the instructions. Only use attachment and accessories specified in the power tool manual. The tool or attachment should not be modified or used for any application other than that for which it was designed. Do not force tool.
3. Keep children and visitors away. Do not let children or visitors touch the tool, accessory or attachment. Keep children and visitors away from work area. Make the workshop child proof with padlock and master switch.
4. Dress properly. Do not wear loose clothing or jewellery, they can be caught in moving parts. Rubber gloves and non-skid footwear is recommended when working

outdoors. Wear protective hair covering to contain long hair.

5. Consider working environment. Do not use the product in the rain or in a damp environment. Keep work area well lit. Do not use power tools near gasoline or flammable liquids. Keep workshop at a comfortable temperature so your hands are not cold. Connect machines that are used in the open via a residual current device (RCD) with an actuation current of 30 mA maximum. Use only extension cables that are approved for outdoor use.
6. The accessory or attachment must be kept level and stable at all times.
7. Keep work area clean. Cluttered workshops and benches can cause injuries. Ensure there is sufficient room to work safely.
8. Secure idle tools. When not in use, tools should be stored in a dry and high or locked up place, out of reach of children.
9. For best control and safety use both hands on the power tool and attachment. Keep both hands away from cutting area. Always wait for the spindle and cutter to stop rotating before making any adjustments.
10. Always keep guards in place and in good working order.
11. Remove any nails, staples and other metal parts from the workpiece.
12. Maintain tools and cutters with care. Keep cutters sharp and clean for better and safer performance. Do not use damaged cutters. Follow instructions for lubricating and changing accessories. Keep handles dry, clean and free from oil and grease.
13. Maintain accessories. Do not use damaged accessories. Only use accessories recommended by the manufacturer.
14. Check damaged parts. Before operation inspect the attachment, the power tool, the cable, extension cable and the plug carefully for signs of damage. Check for alignment of moving parts, binding, breakage, mounting and any other conditions that may effect its operation. Have any damage repaired by an Authorised Service Agent before using the tool or accessory. Protect tools from impact and shock.
15. Do not use tool if switch does not turn it on or off. Have defective switches replaced by an Authorised Service Agent
16. Don't over reach. Keep proper footing and balance at all times. Do not use

awkward or uncomfortable hand positions.

17. Don't abuse the cable. Never carry power tool or accessory by cord or pull it to disconnect from the socket. Keep cord from heat, oil and sharp edges. Always trail the power cord away from the work area.
18. Connect dust extraction equipment. If devices are provided for the connection of dust extraction and collection facilities, ensure these are connected and properly used.
19. Check all fixing and fastening nuts, bolts and screws on power tool, attachment and cutting tools before use to ensure they are tight and secure. Periodically check when machining over long periods.
20. Stay alert. Watch what you are doing. Use common sense. Do not operate tools when you are tired, under the influence of drugs or alcohol.
21. Personal Protective Equipment (PPE) for eye, ear and respiratory protection must be worn. All PPE must meet current UK and EU legislation.
22. Do not leave tools running unattended. Do not leave tool until it comes to a complete stop.
23. Always clamp workpiece being machined securely.
24. Only use cutting tools for woodworking that meet EN847-1/2 safety standards, and any subsequent amendments.
25. Vibration levels. Hand held power tools produce different vibration levels. You should always refer to the specifications and relevant Health & Safety Guide.

Routing Safety

1. Read and understand instructions supplied with power tool, attachment and cutter.
2. Keep hands, hair and clothing clear of the cutter.
3. Remove adjusting keys and spanners. Check to see that keys and adjusting spanners are removed from the router tool, cutter and attachment before turning router on. Make sure cutter can rotate freely.
4. Noise. Take appropriate measures for the protection of hearing if the sound pressure of 85dB(A) is exceeded. Routing sound pressure may exceed 85dB(A), so ear protection must be worn.
5. Eye protection. Always wear eye protection in the form of safety goggles, spectacles or visors to protect the eyes.

6. Respiratory protection. Wear a face or dust mask, or powered respirator. Dust masks/filters should be changed regularly.
7. Do not switch router on with the cutter touching the workpiece. At the end of the cut, release the router plunge and allow spindle to stop rotating. Never use the spindle lock as a brake
8. The direction of routing must always be opposite to the cutter's direction of rotation. Do not back-cut or climb-cut.
9. Check before cutting that there are no obstructions in the path of the router. Ensure there are no obstacles beneath workpiece when cutting full thickness, and that a sacrificial work surface is used.

Router Cutter Safety

1. Cutting tools are sharp. Care should be taken when handling them. Do not drop cutters or knock them against hard objects. Handle very small diameter cutters with extra care. Always return cutter to its packaging after use.
2. Always use cutters with a shank diameter corresponding to the size of the collet installed in your tool.
3. The maximum speed (n.max) marked on the tool, or in instructions or on packaging shall not be exceeded. Where stated the speed range shall be adhered to. Recommended speeds are shown in the Trend Routing Catalogue and/or website.
4. Always use router cutters in a router. Drill and boring bits must not be used in a router. Router cutters must only be used for the material cutting application for which they are designed. Do not use on metal or masonry.
5. Never use cutters with a diameter exceeding the maximum diameter indicated in the technical data of the power tool or attachment used.
6. Before each use check that the cutting tool is sharp and free from damage. Do not use the cutting tool if it is dull, broken or cracked or if in any other damage is noticeable or suspected.
7. Cutters should be kept clean. Resin build up should be removed at regular intervals with Resin Cleaner[®]. The use of a PTFE dry lubricant will reduce resin build up. Do not use PTFE spray on plastic parts.
8. When using stacked tooling (multi-blade, block and groover etc.) on a spindle arbor, ensure that the cutting edges are staggered to each other to reduce the cutting impact.
9. Cutter shanks should be inserted into the collet all the way to the line

indicated on the shank. This ensures that at least ¾ of the shank length is held in the collet. Ensure clamping surfaces are cleaned to remove dirt, grease, oil and water.

10. Observe the correct assembly and fitting instructions in the router instruction manual for fitting the collet, nut and cutter.
11. Tool and tool bodies shall be clamped in such a way that they will not become loose during operation. Care shall be taken when mounting cutting tools to ensure that the clamping is by the shank of the cutting tool and that the cutting edges are not in contact with each other or with the clamping elements.
12. It is advisable to periodically check the collet and collet nut. A damaged, worn or distorted collet and nut can cause vibration and shank damage. Do not over-tighten the collet nut
13. Do not take deep cuts in one pass; take several shallow or light passes to reduce the side load applied to the cutter and router. Too deep a cut in one pass can stall the router.
15. In case of excessive vibrations whilst using the router stop immediately and have the eccentricity of the router, router cutter and clamping system checked by competent personnel
15. All fastening screws and nuts should be tightened using the appropriate spanner or key and to the torque value provided by the manufacturer.
16. Extension of the spanner or tightening using hammer blows shall not be permitted.
17. Clamping screws shall be tightened according to instructions provided by the manufacturer. Where instructions are not provided, clamping screws shall be tightened in sequence from the centre outwards.

Using Routers In A Fixed Position

1. Attention should be made to the HSE's Safe Use of Vertical Spindle Moulding Machines Information Sheet No.18 and any revisions.
2. After work, release the router plunge to protect the cutter.
3. Always use a push-stick or push-block when making any cut less than 300mm in length or when feeding the last 300mm of the cut.
4. The opening around the cutter should be reduced to a minimum using suitably sized insert rings in the table and closing the back fence cheeks or fitting a false fence on the back fence.
5. Whenever possible use a work holding device or jig to secure

component being machined. Ensure any attachment is securely fitted to the workbench, with table surface at approximately hip height.

6. Use a No-Volt Release Switch. Ensure it is fixed securely, easily accessible and used correctly.
7. In router table (inverted) mode, stand to the front right of the table. The cutter will rotate anti-clockwise when viewed from top so the feed direction is from the right (against the rotation of the cutter). In overhead mode, stand to the front left of the machine table and the feed direction is from the left.
8. Do not reach underneath table or put your hands or fingers at any time in the cutting path while tool is connected to a power supply.
9. Never thickness timber between the back of the cutter and the backfence.

Useful Advice When Routing

1. Judge your feed rate by the sound of the motor. Feed the router at a constant feed rate. Too slow a feed rate will result in burning.
2. Trial cuts should be made on waste material before starting any project.
3. When using some attachments e.g. a router table or dovetail jig, a fine height adjuster is recommended.
4. When using a template guide bush, ensure there is sufficient clearance between cutter tip and inside edge of bush and that it cannot come into contact with collet and nut. Ensure cutter and guide bush are concentric.

Router Cutter Repair/Maintenance

1. Repair of tools is only allowed in accordance with the manufacturers instructions.
3. The design of composite (tipped) tools shall not be changed in process of repair. Composite tools shall be repaired by a competent person i.e. a person of training and experience, who has knowledge of the design requirements and understands the levels of safety to be achieved.
4. Repair shall therefore include, e.g. the use of spare parts which are in accordance with the specification of the original parts provided by the manufacturer.
5. Tolerances which ensure correct clamping shall be maintained.
6. Care shall be taken that regrinding of the cutting edge will not cause weakening of the body and the connection of the cutting edge to the body.

Version 7.1 06/2006

ELECTRICAL SAFETY



Power Supply

The electric motor has been designed for one voltage only. Always check that the power supply corresponds to the voltage on the rating plate. Machines marked for 230 volt can also be operated from a 220 volt supply.



The T10 & T11 is double insulated in accordance with EN 50144; therefore no earth wire is required.

Mains Plug Replacement (UK & Ireland only)

Always check the condition of the cable and plug before starting with your work.

Should your mains plug need replacing and you are competent to do this, proceed as instructed below. If you are in doubt, contact an authorised Trend repair agent or a qualified electrician.

- Disconnect the plug from the supply.
- Cut off the plug and dispose of it safely; a plug with bared copper conductors is dangerous if engaged in a live socket outlet.
- Only fit 13 Amperes BS 1363A approved plugs fitted with a 13 Amp A.S.T.A approved BS 1362 fuse (1).
- The cable wire colours, or a letter, will be marked at the connection points of most good quality plugs. Attach the wires to their respective points in the plug (see below). Brown is for Live (L) (2) and Blue is for Neutral (N) (3).
- Before replacing the top cover of the mains plug ensure that the cable restraint (4) is holding the outer sheath of the cable firmly and that the two leads are correctly fixed at the terminal screws.

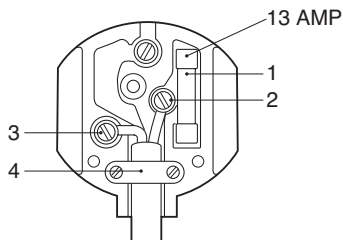

Never use a light socket. Never connect the live (L) or neutral (N) wires to the earth pin marked E or $\frac{1}{2}$.

Using an Extension Cable

- If an extension cable is required, use an approved triple core extension cable suitable for the power input of this tool (see technical data).
- When using a cable reel, always unwind the cable completely.
- Also refer to the table below.

Conductor size (mm ²)	Cable rating (Amperes)
0.75	6
1.00	10
1.50	15
2.50	20
4.00	25

		Cable length (m)					
		7.5	15	25	30	45	60
Voltage	Amperes	Cable rating (Amperes)					
115	0 - 2.0	6	6	6	6	6	10
	2.1 - 3.4	6	6	6	6	15	15
	3.5 - 5.0	6	6	10	15	20	20
	5.1 - 7.0	10	10	15	20	20	25
	7.1 - 12.0	15	15	20	25	25	-
	12.1 - 20.0	20	20	25	-	-	-
230	0 - 2.0	6	6	6	6	6	6
	2.1 - 3.4	6	6	6	6	6	6
	3.5 - 5.0	6	6	6	6	10	15
	5.1 - 7.0	10	10	10	10	15	15
	7.1 - 12.0	15	15	15	15	20	20
	12.1 - 20.0	20	20	20	20	25	-

For 115V units with a power rating exceeding 1500W we recommend to use a plug to BS4343 standard. For T10 & T11 this must be rated to 32A.

**MANUFACTURERS
DECLARATION**

CE T10E & T11E

We declare under our sole responsibility that this product is in conformity with the following standards of standardised documents:

EN 60745, EN 55014, EN 55014-2, EN 61000-3-2, EN 61000-3-3 in accordance with the directives 2006/42/EC, 2004/108/EC.

Level of sound pressure according to 86/188/EEC & 2006/42/EC, measured according to EN 60745:

Lpa (sound pressure) 93 dB(A)₁
Lwa (acoustic power) 102 dB(A)₂

Radio and TV suppression in compliance with 76/889/EEC and 82/499/EEC



**INFORMATION ON
NOISE/VIBRATION**

The noise level when working can exceed 85 dB(A).

Wear ear protection!

Weighted root mean square acceleration value according to EN 60745:

< 2.5 m/s²

Managing Director
Jeff Willcocks

Trend Machinery & Cutting Tools Ltd.

ITEMS ENCLOSED

T10

- 1 x Parallel side-fence with micro adjuster
- 1 x Fence rods (pair)
- 1 x Collet 1/2" (12.7mm) UK & Eire (Europe 12mm)
- 1 x Spanner (22mm A/F)
- 1 x Guide bush 30mm and fixing screws
- 1 x Inner plate and fixing screws
- 1 x Line-up pin 12mm/1/2"
- 1 x Dust extractor spout with fixing screws
- 1 x Dust extractor spout clip
- 1 x Instruction manual
- 1 x Guarantee registration card

T11

- 1 x Parallel side-fence with micro adjuster
- 1 x Fence rods (pair)
- 1 x Collet 1/2" (12.7mm) UK & Eire (Europe 12mm)
- 1 x Spanner (22mm A/F)
- 1 x Guide bush 30mm and fixing screws
- 1 x Inner plate and fixing screws
- 1 x Line up pin 12mm/1/2"
- 1 x Dust extractor spout with fixing screws
- 1 x Dust extractor spout clip
- 1 x Fine height adjuster handle
- 1 x Instruction manual
- 1 x Guarantee registration card

DESCRIPTION OF PARTS T10

- (A) Plunge locking lever
- (B) Variable speed control dial
- (C) Handle
- (D) Switch
- (E) Depth stop locking knob
- (F) Depth stop micro adjuster
- (G) Depth stop height adjuster dial
- (H) Depth stop scale
- (I) Depth stop lens
- (J) Thumb knob with anti-vibration spring for side fence
- (K) Collet nut
- (L) Spindle lock
- (M) Base
- (N) 3-way turret stop
- (O) Collet
- (P) Knurled nut
- (Q) Threaded spindle
- (R) Threaded spindle cap nut
- (S) Template guide bush dia. 30mm
- (T) Template guide fixing screw
- (U) Fence rods dia. 10mm x 360mm
- (V) Parallel side fence
- (W) Parallel side fence micro adjuster knob
- (X) Spanner (22mm A/F)
- (Y) Dust spout 35mm dia.
- (Z) Dust spout fixing screws
- (AA) Dust spout fixing nut
- (AB) Dust spout insert
- (AC) Dust spout top clip
- (AD) Dust spout top clip screw
- (AE) Dust Spout underside clip
- (AF) Template guide bush line-up pin
- (AG) Inner plate fixing screws
- (AH) Inner plate

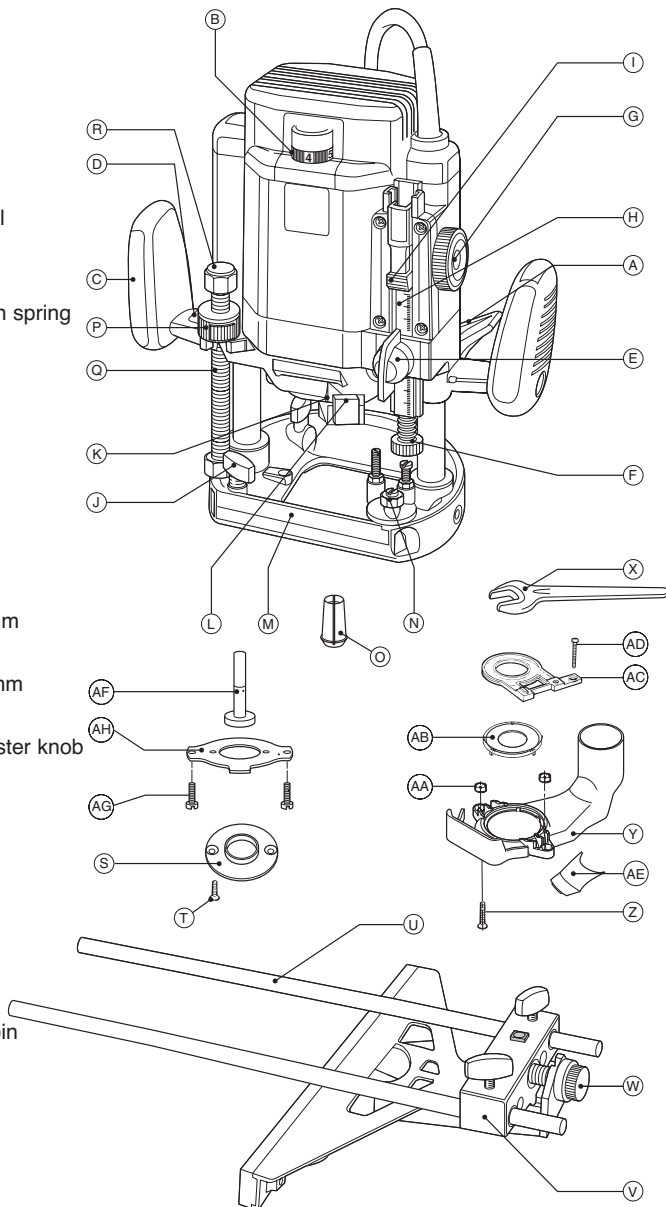

DESCRIPTION OF PARTS T11

- (A) Plunge locking lever
- (B) Variable speed control dial
- (C) Handle
- (D) Switch
- (E) Depth stop locking knob
- (F) Depth stop micro adjuster
- (G) Depth stop height adjuster dial
- (H) Depth stop scale
- (I) Depth stop lens
- (J) Thumb knob with anti-vibration spring for side fence
- (K) Collet nut
- (L) Spindle lock
- (M) Base
- (N) 3-way turret stop
- (O) Collet
- (P) Knurled nut
- (Q) Threaded spindle
- (R) Threaded spindle hex cap nut
- (S) Template guide bush dia. 30mm
- (T) Template guide fixing screw
- (U) Fence rods dia. 10mm x 360mm
- (V) Parallel side fence
- (W) Parallel side fence micro adjuster knob
- (X) Spanner (22mm A/F)
- (Y) Dust spout 35mm dia.
- (Z) Dust spout fixing screws
- (AA) Dust spout fixing nut
- (AB) Dust spout insert
- (AC) Dust spout top clip
- (AD) Dust spout top clip screw
- (AE) Dust spout underside clip
- (AF) Quick release jig & table aperture
- (AG) Clamp guide system fitting
- (AH) Inner plate
- (AI) Inner plate fixing screw
- (AJ) Fine height adjuster handle
- (AK) Template guide bush line-up pin
- (AL) Fine height adjuster handle dial

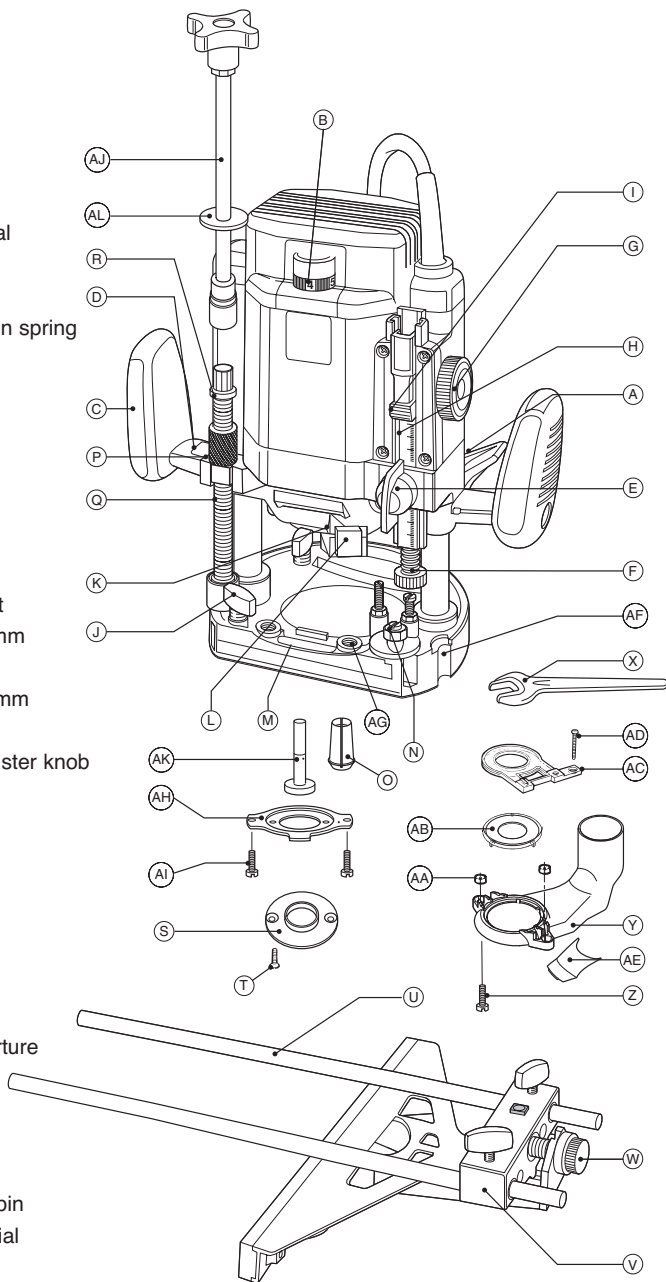

ASSEMBLY & ADJUSTMENT

Switching On & Off

- On; pull the switch up.
- Off; press the switch down.

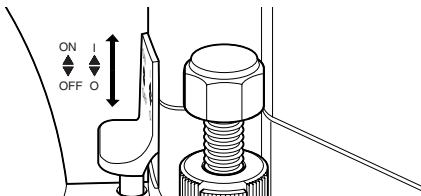

Adjusting the Depth of Cut

- Place the machine with cutter fitted on to the workpiece.
- Pre-set the 3-way turret stop (1) as required.
- Undo the thumb knob (2) for securing the depth stop (3).
- Lift up the plunge locking lever (4) for fixing the depth.
- Lower the machine slowly until the cutter touches the workpiece and secure it with the locking lever.
- Rotate the knob (6) until the depth stop micro adjuster (3) touches the revolving depth stop (1).



- **Never make adjustments when the router is running or plugged in.**
- **Deep cuts should always be routed in several passes.**
- **When in plunging mode never release the plunge lever without the base of the router supported on a flat surface as this may damage the router housing or could cause injury.**

If the depth of cut needs re-adjustment, it is recommended to use the depth stop micro adjuster.

- Adjust the depth of cut using the depth stop micro adjuster (3). One turn corresponds to approximately 1mm.

- Read the depth of cut using the measuring lens (5) and scale.
- Adjust the depth of cut to the millimetre using the knob (6).

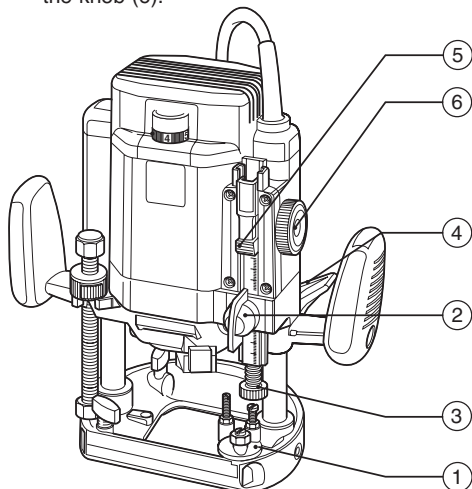

- Set the measuring lens (5) to a round figure or zero.
 - Adjust the depth of cut using the knob (6) and the measuring lens (5).
- The distance between the top of the revolving stop and the bottom of the depth stop is the required depth of cut.
- Tighten the knob (2).

The rotating turret stop screws can be used for pre-setting up to three depths of cut. Their height can be adjusted using a screwdriver (7) and an 8mm A/F spanner (8).

By turning the turret stop, three depth settings can be quickly made.

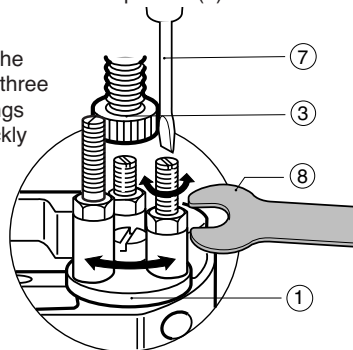

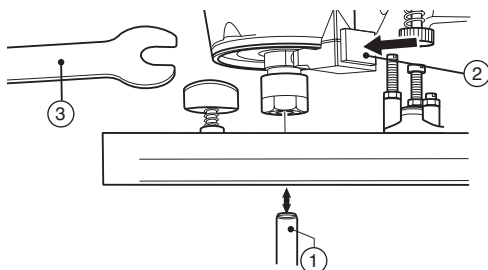
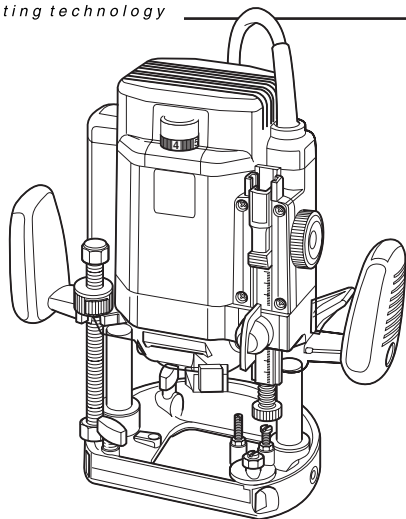

Correct Sequence for Fitting Collet, Nut and Cutter

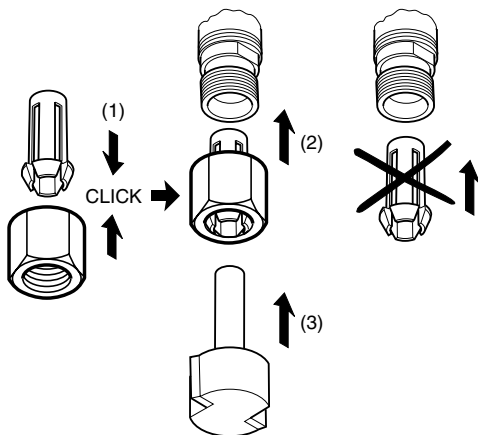

How to Fit and Remove a Router Cutter



Fitting Cutters



- Insert at least $\frac{3}{4}$ of the shank length of the cutter (1) into the collet.
- Press the spindle lock (2) forward until the router spindle is locked (you may need to turn the spindle slightly to engage it).
- Tighten the collet nut with a spanner (3). Do not use excessive force.

Removing Cutters



- Undo the 22mm A/F collet nut with the spanner.
- Keep turning the spanner until the collet nut tightens and then loosens again. This is the fail-safe mechanism releasing the collet.
- The cutter should now slide out.
- Each time you finish using a cutter, remove it and store it in a safe place.



- Do not tighten the collet without a cutter fitted.
- Always use cutters with shanks which match the diameter of the collet.
- Do not use cutters larger than 45mm unless the router is fitted in a router table.
- Care should be taken when removing cutter to avoid cuts to fingers.

Setting the Electronic Speed Control Dial



The speed is infinitely variable from 8,000 to 20,000 rpm using the electronic speed control dial (1) for uniform cutting results in all types of wood, plastics and in aluminium.

- Turn the electronic speed control dial to the required level. The dial is numbered from 1 to 5 and corresponds to router speeds from 8,000 rpm to 20,000 rpm.
- Generally, use the lower settings for large diameter cutters and the higher settings for small diameter cutters. The correct setting will also depend on the density of the material, depth of cut and feed speed of the router, as severe loss of rpm denotes motor overload.

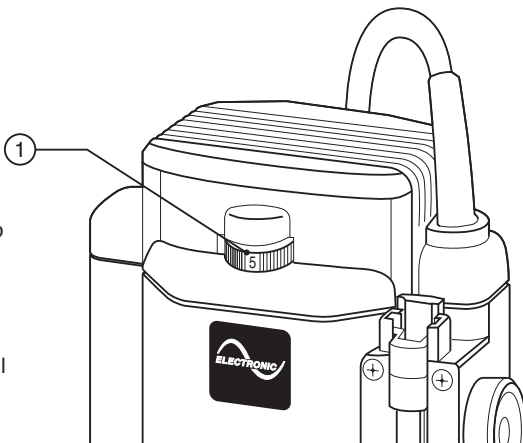

Dial No.	Router Speed
1	8,000 rpm
2	12,000 rpm
3	16,000 rpm
4	18,000 rpm
5	20,000 rpm

Fixing Points for Accessories

The router has three threaded holes M6 in its base that allow fitting of accessories and also fitting to router tables.

A whole range of accessories are shown in the Trend Routing Catalogue.

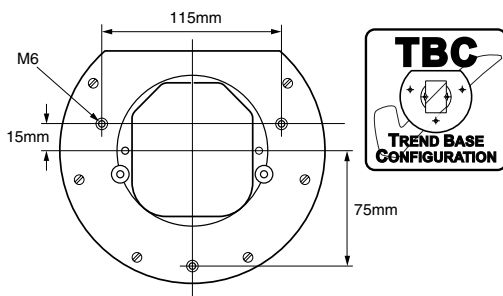

Using a Fine Height Adjuster

The T10 has an optional fine height adjuster accessory Ref. FHA/003 and the T11 has a built in fine height adjuster called the Quick Raiser. These should be used when fine height adjustment of the cutter is required. This is especially recommended when using dovetail jigs or router tables.

T10



Fitting and Removing T10 Dust Extractor Spout

The dust extraction spout consists of a main section (1) with underside clip (7), an insert cover (2), top clip (5) with screw (6), two main screws (3) & two nuts (4).

- Check underside clip (7) is fitted into main section. Slide the insert cover (2) onto the main section if required (1) and click into place.
- Fit nuts (4) into main body. Place spout into base of router and secure with two screws (3).
- Connect a dust extractor hose to the dust extraction spout (1).
- The top clip (5) can be used with hoses that have a removable adapter fitted. Loosen the screw in the top of the router and fit the top clip (5) as shown using screw (6).

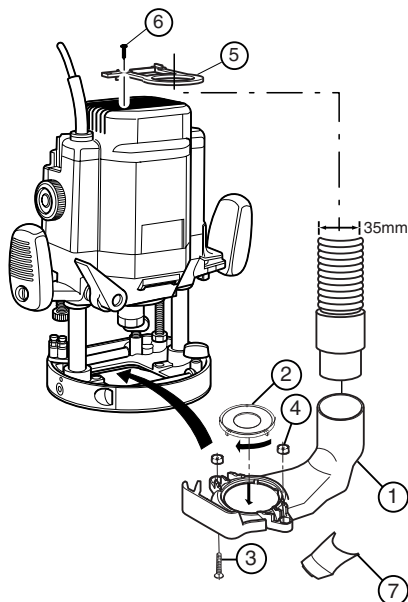

Whenever possible use the dust extraction spout with a suitable extractor when routing.



Top clip (5) cannot be used with vacuum extractor hoses with a permanent adapter fitted.

Fitting the T10 Fine Height Adjuster Optional Accessory Ref. FHA/003

- Plunge router and lock lever (6) down.
- Remove hex cap (5) nut from threaded stud (3), using a 19mm A/F spanner.
- Remove knurled ring nut (4) from threaded stud (3).
- Place washer (2) on threaded stud.
- Thread on main adjuster rod (1) for at least 25mm of thread.

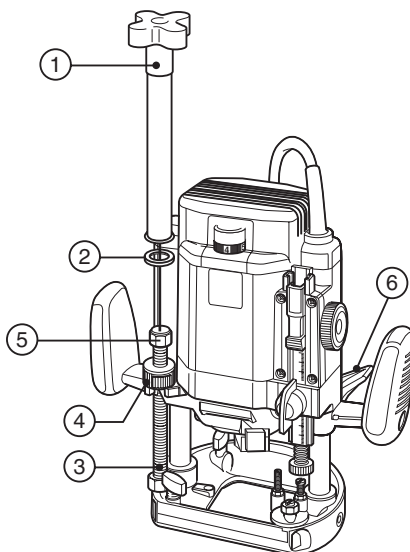

T10 & T11

Fitting Template Guide Bush and Inner Plate

The routers have a unique built-in line up system for the template guide bush. This system ensures that the guide bush is exactly concentric to the router cutter to ensure accurate work.

- Turn the router upside down.
- Fit inner plate (2) into the recess in the router base plate (1). For T10 the bushes on the inner plate must be towards the router motor. For T11 the raised side of the inner plate must be away from router base. Loosely fit the two pan head machine screws (3) through the inner plate and into the tapped holes.

DO NOT TIGHTEN SCREWS.

- Fit the 30mm template guide bush (6) to the inner plate (2). Fit guide bush with the two M5 countersink machine screws (7). Tighten these screws.
- The line up pin (5) is stepped for 12mm and 1/2" collet (4) sizes. (For the 1/2" collet simply push the line up pin further down into the 1/2" collet).
- Fit line up pin (5) into the 1/2" collet (8) (or 12mm depending on the size fitted) in the router, lightly tighten collet nut to hold the line up pin (5).
- Release plunge lever and gently depress base until line up pin (5) projects through the 30mm guide bush (6).
- Once in line, tighten the pan head machine screws (3) with a flat screwdriver.

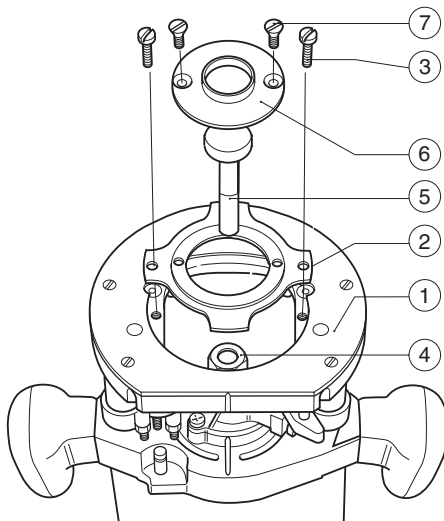

T11



Fitting and Removing T11 Dust Extractor Spout

The dust extraction spout consists of a main section (1) with underside clip (7), an insert cover (2) and top clip (5) with screw (6).

- Check underside clip (7) is fitted into main section. Slide the insert cover (2) onto the main section if required (1) and click into place.
- Clip into the base by pushing down the dust extraction spout (1) until clips engage in the recess.
- Connect a dust extractor hose to the dust extraction spout (1).
- The top clip (5) can be used with hoses that have a removable adapter fitted. Loosen the screw in the top of the router and fit the top clip (5) as shown using screw (6).
- To remove dust extraction spout, push spout (1) to side and pivot out.

For more permanent fixing, fit nuts (4) into main body, place spout into base of router and secure with two screws (3).



Top clip (5) cannot be used with vacuum extractor hoses with a permanent adapter fitted.

Using the T11 Without Fine Height Adjuster

In portable use the knurled nut (2) should be wound to the top of the stud and hand tighten against the hex cap. The base of the knurled nut (4) should be aligned with the forks (3) in the router casting.



In normal plunge mode, ensure the base of the knurled nut is aligned correctly with the forks of the lower motor housing. This will enable the cutter to retract into the base safely.

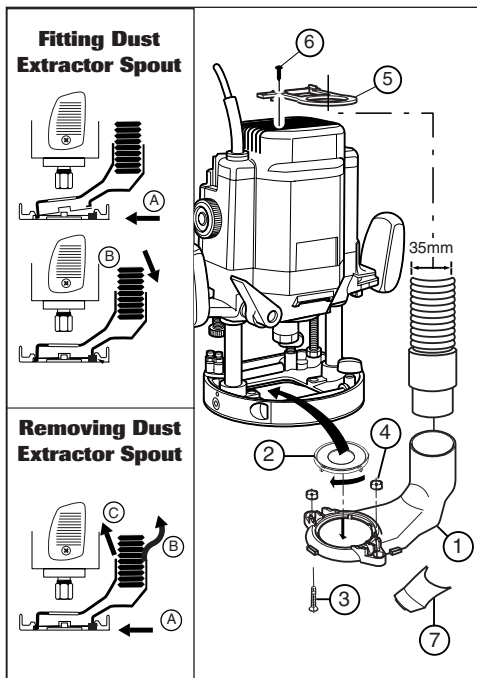

Whenever possible use the dust extraction spout with a suitable extractor when routing.

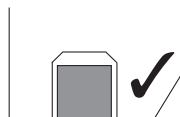
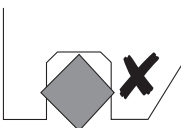
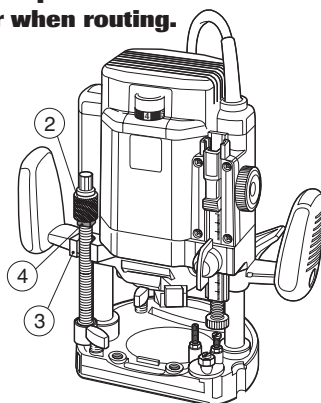

Fitting the T11 Fine Height Adjuster

The fine height adjuster (Quick Raiser) for the T11 can be used portably or when the router is held inverted in a table. If a suitable size access hole is drilled into the router table top, the height adjustment can also be adjusted from above the table top.

To set up for fine height adjustment:

- Plunge router and lock lever down (1).
- Rotate the knurled nut (2) down the stud until it is close to the router casting forks (3).
- Align the base of the knurled nut (4) so that it will locate in the forks (3).
- Release plunge locking lever (1).



Do not use a powered drill to drive the T11 Quick Raiser assembly. Only use the supplied handle. Ensure that the plunge locking lever is unlocked. Never use unnecessary force to rotate the Quick Raiser mechanism. Do not undo Torx[®] screw on hex nuts.

For Portable Use

- Place the fine height adjuster handle (5) onto the top threaded spindle hex nut (6).
- Rotate handle clockwise to raise motor body and reduce cutter depth.
- Rotate handle anti-clockwise to lower motor body and increase cutter depth.

For Router Table Use



- Ensure router is fitted into the router table (10), see opposite page.
- Place fine height adjuster handle (5) through router table cutter hole onto bottom threaded spindle hex nut (9).
- Rotate handle clockwise to raise motor body and raise cutter height.
- Rotate handle anti-clockwise to lower motor body and lower cutter height.

One revolution corresponds to 1.5mm. The height adjuster handle dial (7) can be reset to zero.

Portable Use

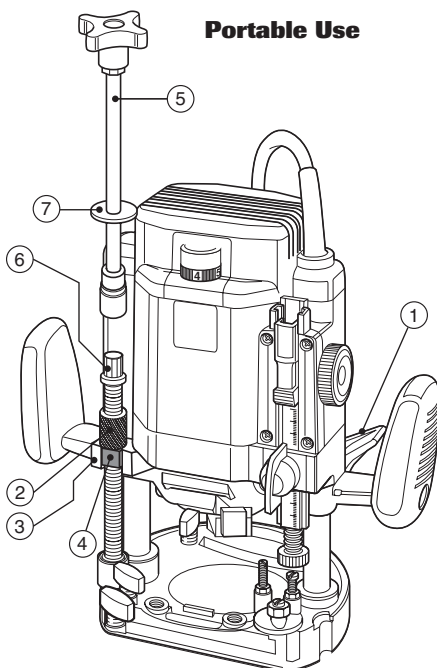

Inverted Use

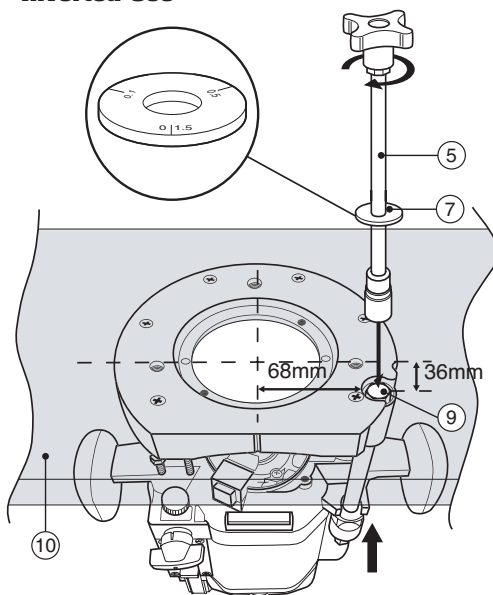

**Modification of User Router Table for T11
Fine Height Adjuster**

To use fine height adjuster in table mode a 20mm diameter hole is required to be drilled into the router table top. To position the hole it is advisable to remove the phenolic base slider of the T11 router and use it as a template.

- Mark the hole for the handle height adjuster in the table top using the phenolic base slider as a template.
- Remove the phenolic base slider.
- Mark with a punch the centre of the hole.
- Drill a pilot hole in the centre.
- Enlarge the hole to 20mm.
- Remove any burrs.

A template is provided on page 28.

**T11 Quick Release Fixing Kit
Optional Accessory Ref. T11/JT/KIT**

The T11 Quick Release Fixing Kit uses three cams (1) to lock the router into a router table. The kit can be retro-fitted to user-made tables by drilling suitable size holes in a set pattern into the table surface. The kit comprises three cams, three bosses, three springs and three nut & bolt assemblies. The kit is supplied with instructions for drilling and using the cams. The cams locate into the three apertures (2) in the base of the T11 router.



When using large panel raiser cutters, making deeps or if the router is to be used inverted for long periods, the router should also be secured using three M6 machine screws into the TBC router fixing holes.

**T11 Clamp Guide System Optional
Accessory Ref. T11/CGS/KIT**

The T11 has two M6 tapped holes in the upper face of the router base (3), which will accept the Clamp Guide System accessory (4). The accessory is used with the Clamp Guide System clamps (5) and is used to create parallel grooves and trenches.

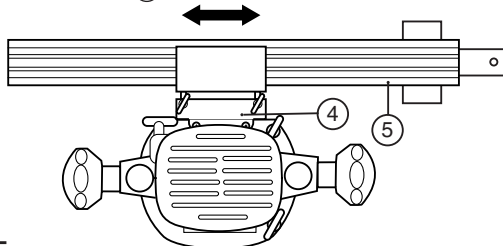
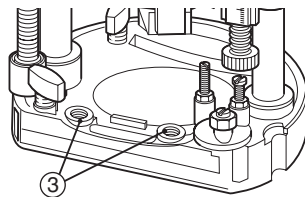
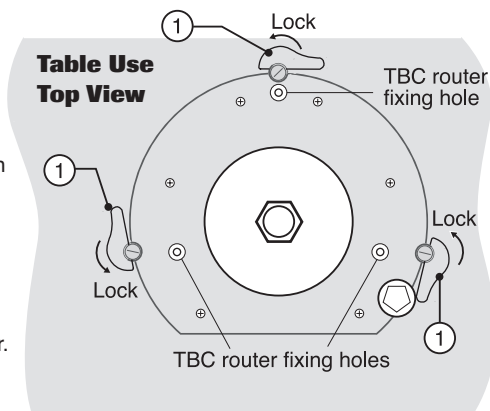
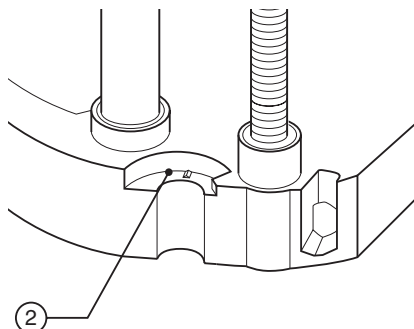

OPERATION



Cutting Direction



The direction of routing must always be opposite to the cutter's direction of rotation. Otherwise there is a risk of kick-back.

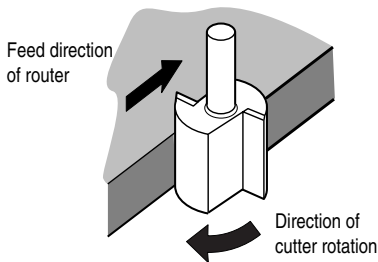

Feed Direction

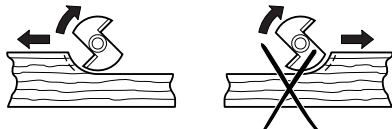

When routing along an edge, the direction of the router travel should be against that of the rotation of the cutter. This will create the correct cutting action and prevent the cutter 'snatching'. It will also pull the router towards the workpiece and hence the side-fence or guide bearing will be less likely to wander from the edge of the workpiece.

Feed Speed



The speed at which the cutter is fed into the wood must not be too fast that the motor slows down, or too slow that the cutter leaves burn marks on the face of the wood. Practice judging the speed by listening to the sound of the motor when routing.

Sequence of plunging

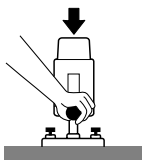

Step One
Plunge down and lock the motor carriage, by depressing the plunge locking lever.

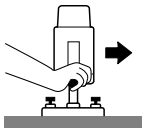

Step Two
Carry out the routing operation.

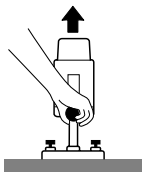

Step Three
Release the plunge locking lever and the motor carriage returns to the normal position.



When routing always lock the plunge locking lever.

Moulding Natural Timbers



When edge moulding natural timbers, always mould the end grain first, followed by the long grain. This ensures that if there is 'breakout', this will be removed when the long grain is routed.

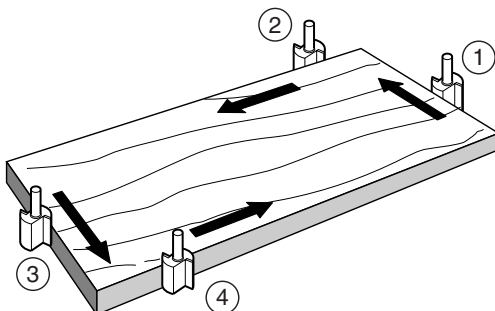

Side-Fence Routing

The side-fence is used to guide the router when moulding, edge profiling or rebating the edge of the workpiece or when routing grooves and slots in the centre of the workpiece, parallel to the edge.

The edge of the workpiece must be straight and true. The cheeks are adjustable and should be set ideally with a 3–4mm gap each side of the cutter.

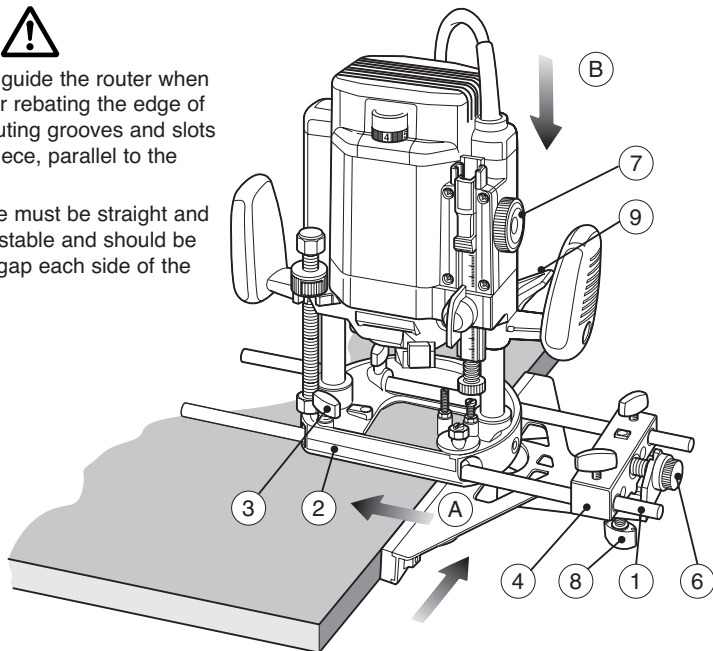

Fitting and using the Side Fence

- Make sure the thumb knobs (3) are fully released. Slide the guide rods (1) into the routing base (2) and tighten the thumb knobs (3).
- Adjust the side-fence (4) to the required distance and clamp in place with the thumb knobs (3).
- Then lower the cutter until the cutter is just above the workpiece.
- Fine adjustments are possible by slackening the underside locking knob (8), adjusting the micro-adjustment knob (6) and securing it again with the knob (8). One revolution of the micro-adjustment knob (6) equals 1.0mm of side-feed.
- Lower the cutter onto the workpiece and set the cutter height by raising the depth stop (7) the required distance.
- Switch on the router and when the cutter reaches full speed, gently lower the cutter into the workpiece and lock the plunge.

- Feed along the timber, keeping sideways pressure (A) to ensure the side fence does not wander away from the workpiece edge and downward pressure on the inside hand (B) to prevent the router from tipping.
- When finished, raise the router, secure with the plunge locking lever (9) and switch off.

When starting the cut, keep the pressure on the front cheek (C) until the back cheek contacts the workpiece edge.

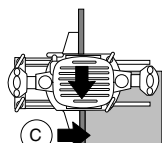

At the end of the cut, keep pressure on the back cheek (D) until the cut is finished. This will prevent the router cutter swinging in at the end of the workpiece and 'nipping' the corner.

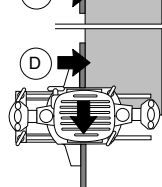

Routing with a Template 

The guide bush is used in conjunction with a template when the routing operation is repetitive or the workpiece is complex in shape. The template is fixed to the upper surface of the workpiece. A cutter is chosen with a diameter which will pass through the centre of the bush leaving enough clearance. The cutter can be straight or shaped. The router can then be guided around the template so that the shape of the template will be replicated.

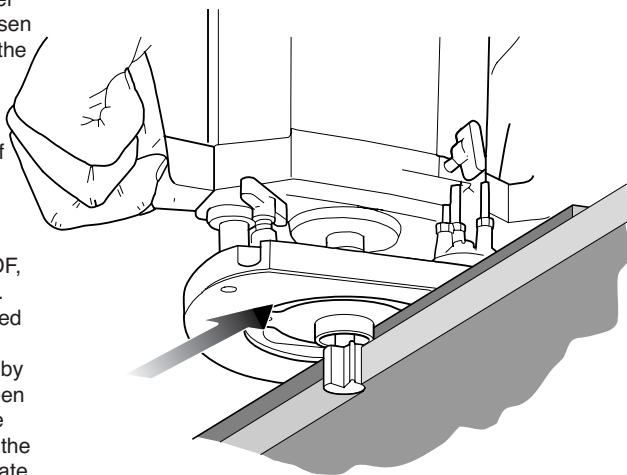

Making the Template 

The template is cut from 6mm or 1/4" MDF, plywood or plastic to the shape required. The guide bush offset needs to be allowed for when calculating the shape of the template. The template must be smaller by an amount equal to the difference between the 'outer edge of the guide ring' and the 'outer edge of the cutter'. See below for the offset calculation. The edge of the template must be free of imperfections as these will be replicated in the final workpiece.

Using a template to rout a straight edge

Calculations for template offset

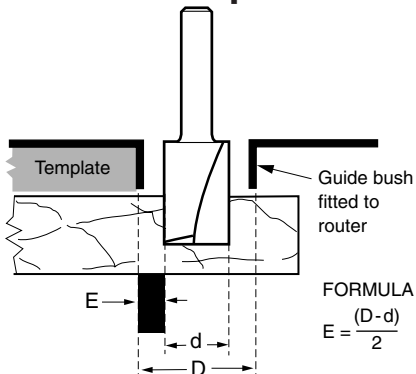

Alternatively it can be used for cutting shapes or making panelling grooves.

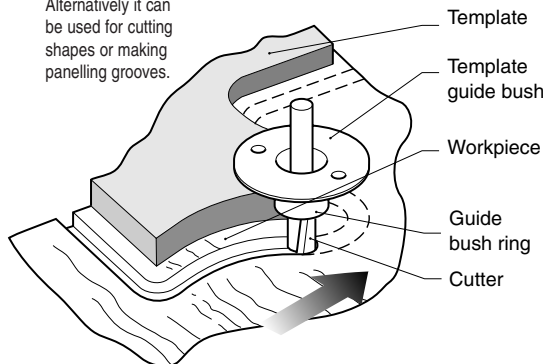

Beam Trammel Routing



Optional Accessory

Ref. BEAM/002

Cutting Arcs with the Router



- Fit the beam trammel (1) to the router base (3).
- Place the machine on the workpiece and ensure pin on beam trammel will pierce the workpiece surface.
- Measure the radius and fix the point of the beam trammel in position.
- Fasten the beam trammel (1) in the routing base (3) with the thumb knob (4).
- Set the cutting depth using the depth stop dial (2).
- Switch on the machine.
- After releasing the plunge locking lever (5), lower the machine slowly as far as the depth stop and lock it there.
- Cut grooves, rebates etc. at a steady rate of feed, in an anti-clockwise direction.
- When finished, release plunge locking lever (5) to raise the machine.
- Switch off the machine.

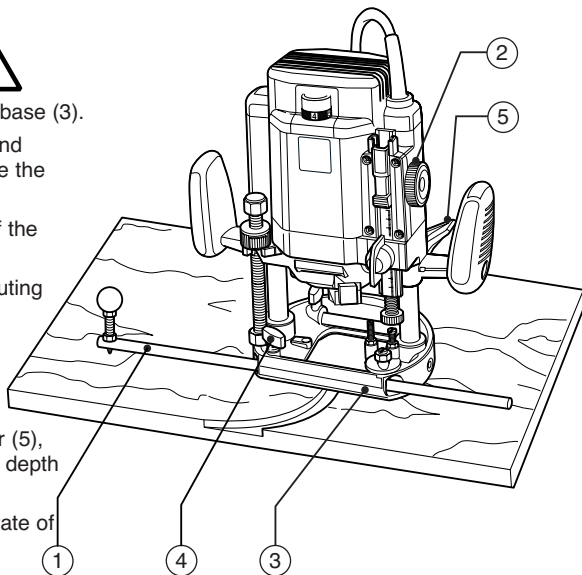

Ensure the beam trammel point does not move, and that the cable will not foul.

Bearing Guided Cutter Routing

Edge profiling and shaping cutters are available with a bearing fitted to the end. This enables shaped or straight workpieces to be routed without the need for a guiding device such as a side-fence or batten.

The edge must be free from imperfections as these will be reflected in the finish of the mould. Often alternative diameters of bearings are offered which will change the shape of the resulting mould.

With certain shapes such as the chamfer cutter below, increasing the depth of cut will produce a larger chamfered edge.

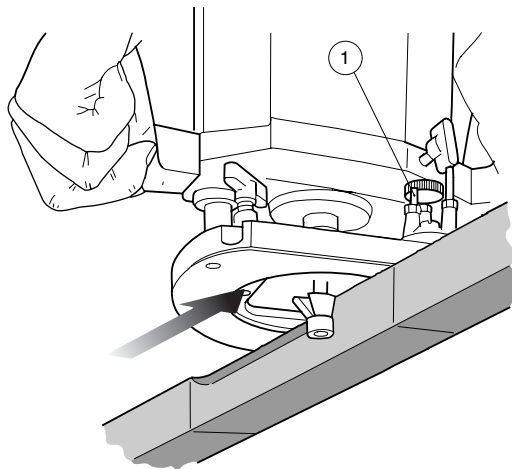

- Fit the bearing guided cutter into the router collet.
- Place router onto the workpiece.
- Set height of cutter using the depth stop (1).
- Switch on the machine.
- After releasing the plunge locking lever, lower the machine slowly as far as the depth stop.
- With bearing of cutter running along board edge, mould the edge of the workpiece by moving the router in the direction shown.
- A continuous motion should be used to prevent burning of the workpiece. When possible, take a number of passes at increased cutter depths. A light final pass will produce a good finish.
- When complete, retract the carriage by releasing the plunge locking lever.
- Switch off the router.

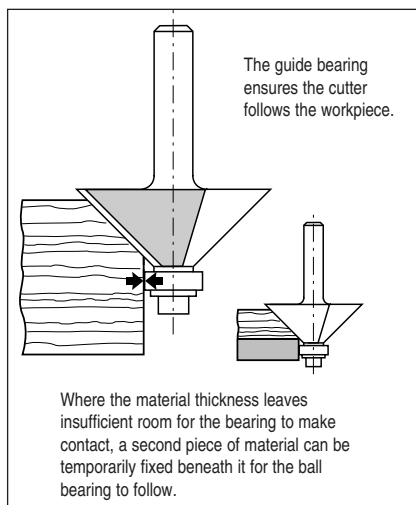

Keep downward pressure with the inside hand to prevent the router from tipping.

Freehand Routing with the Router

The router can also be used for signwriting or creative freehand work without any form of guide.

With practice, numbers or name plate designs can be routed freehand. Draw the design or motif on the workpiece and then rout the design, taking shallow passes.

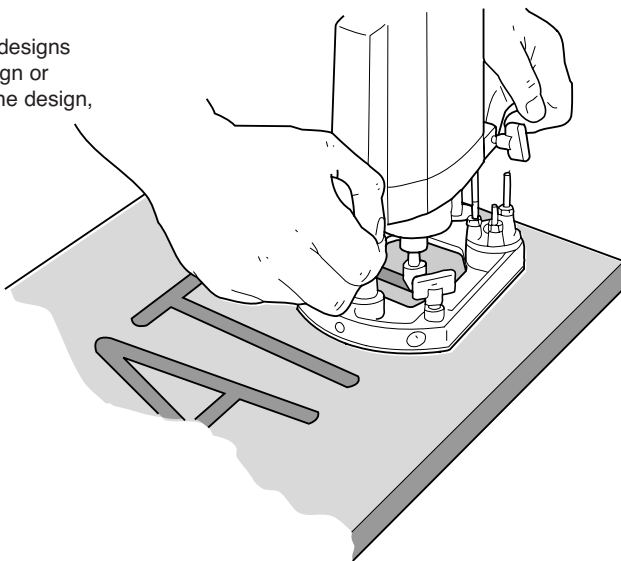
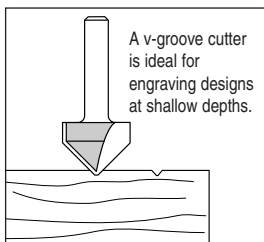

Clamp Guide and Batten Routing

Where a side fence cannot be used, it is also possible to guide the router along a Clamp Guide or batten clamped across the workpiece. The Clamp Guides have built in clamping.

Use the straight edge of the router base and calculate the distance required from the edge of the Clamp Guide to the cut required.

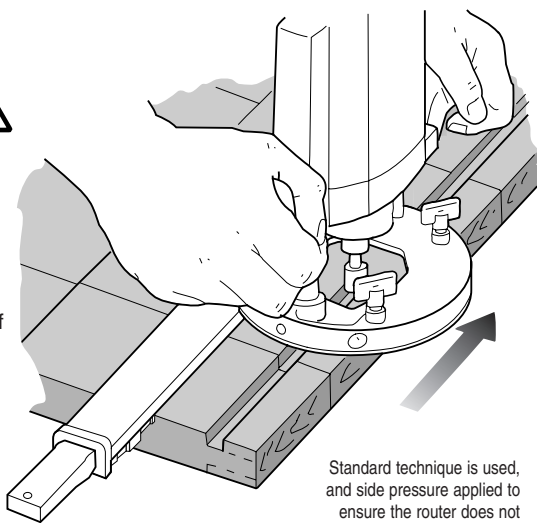

Standard technique is used, and side pressure applied to ensure the router does not wander from the Clamp Guide.

MAINTENANCE AND CARE

Cleaning

- Keep the machine clean at all times. Some maintenance products and solvents may damage the plastic parts, these include products containing Benzene, Trichloroethylene Chloride and Ammonia.
- Never use any caustic agents to clean the plastic parts.

Changing Brushes



Ensure machine is isolated from power supply.

The carbon brushes will need replacing when they become worn to a certain limit.

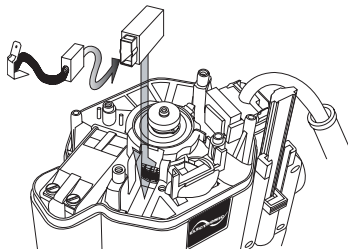

It is advisable to have the brushes replaced by an authorised Trend Service Agent. The router will also be given a thorough inspection.

- Undo the two screws and take off the top cover. Then undo the two screws and move variable speed control out of the way.
- Undo the screws holding the brush holder clamp and remove holder with brush.
- Remove leads, pull on brush tab and remove brush and fit new brush into holder. Then refit lead and replace brush assembly into the housing.
- Refit brush holder cover and screws.
- Refit speed control to position and secure with screws and replace cover and secure with screws.
- Always use original T10/T11 spare parts.

Lubrication

- The bearings of the machine need no lubrication, as they are sealed. The two plunge columns on the routing base should be slightly oiled from time to time.
- Keep the cooling vents on the motor housing clean and unobstructed at all times. Blow out any dust and dirt at regular intervals.
- Visually check the carbon brushes. In the event of excessive sparking, they may need changing.
- After about 40 operating hours inspection by a authorised Trend Service Agent is recommended.

ENVIRONMENTAL PROTECTION



Recycle raw materials instead of disposing as waste.

Accessories and packaging should be sorted for environmental-friendly recycling.



Separate collection. This product must not be disposed of with normal household waste.

Household User

Local regulations may provide for separate collection of electrical products from the household, at municipal waste sites or by retailer when you purchase a new product.

Please call Trend Technical Support for advice as to how to dispose of unwanted Trend electrical product in an environmentally safe way or visit www.trend-uk.com

Business User

Please call Trend Customer services for disposal of unwanted Trend electrical products.

GUARANTEE

This unit carries a manufacturers guarantee in accordance with the conditions on the enclosed guarantee card.

For the location of your nearest Trend Service Agent, please call Trend Customer Services or see Stockist Locator at www.trend-uk.com

T10 & T11- SPARE PARTS LIST			v4.0 10/2010
No.	Qty.	Desc.	Ref.
1	1	Armature 115V T10EL & T11EL c/w Fan <10/09	} See No. 114
	1	Armature 230V T10E & T11E c/w Fan <10/09	
	1	Armature 115V T10EL & T11EL c/w Fan >10/09	WP-T10EL/001A WP-T10E/001A
	1	Armature 240V T10E & T11E c/w Fan >10/09	
2	1	Field Coil 115V T10EL & T11EL <10/09	} See No. 114
	1	Field Coil 230V T10E & T11E <10/09	
	1	Field Coil 115V T10EL & T11EL >10/09	WP-T10EL/002A WP-T10E/002A
	1	Field Coil 230V T10E & T11E >10/09	
3	1	Switch	WP-T10E/003
4	2	Carbon Brush 115V (1 pair) <10/09	WP-T10EL/004
	2	Carbon Brush 240V (1 pair) <10/09	WP-T10E/004
	2	Carbon Brush 115V (1 pair) T10EL & T11EL >10/09	WP-T10EL/004A
	2	Carbon Brush 240V (1 pair) T10E & T11E >10/09	WP-T10E/004A
5	1	2 Core Cable Only 115V UK T10L & T11L	WP-T10L/005
	1	2 Core Cable with Plug 230V UK T10 & T11	WP-T10/005
	1	2 Core Cable with Plug 230V Euro T10&T11/EURO	WP-T10EUR/005
6	2	Brush Holder <10/09	WP-T10/006
	2	Brush Holder >10/09	WP-T10/006A
7	1	Top Vent Housing	WP-T10/007
8	1	Field Housing	WP-T10/008
9	2	Lead Field to Brush 115V (Yellow x 95mm)	WP-T10L/009
	2	Lead Field to Brush 230V (Yellow x 175mm)	WP-T10/009
10	1	Lead Speed Control (Red x 100mm F90-M)	WP-T10/010
11	1	Switch Lever	WP-T10/011
12	1	Machine Screw Csk M4 x 6mm Phillips	WP-T10/012
13	1	Switch Slider	WP-T10/013
14	2	Brush Holder Clamp	WP-T10/014
15	4	Screw Self Tapping Pan 3.8mm x 12mm Phillips	WP-T10/015
16	1	Top Bearing 12mm x 32mm x 10mm 6201-2RSL	WP-T10/016
17	1	Circlip	WP-T10/017
18	2	Screw Self Tapping Dome 4mm x 25mm Phillips	WP-T10/018
19	1	Cable Guard 115V T10L & T11L	WP-T10L/019
	1	Cable Guard 240V T10 & T11	WP-T10/019
20	4	Bolt Pan M5 x 68mm Phillips	WP-T10/020
21	4	Washer Split M5	WP-T10/021
22	2	Screw Self Tapping Pan 3.2mm x 13mm Phillips	WP-T10/022
23	1	Cable Clamp	WP-T10/023
24	1	Lead Switch to Field (Red x 95mm F-M)	WP-T10/024
26	1	Depth Stop Support (Left Hand)	WP-T10/026
27	1	Depth Stop Support (Right Hand)	WP-T10/027
28	1	Depth Stop Lens	WP-T10/028
29	4	Screw Self Tapping Dome 3.8mm x 14mm PH	WP-T10/029
30	1	Half Nut Hex M12	WP-T10/030
31	2	Screw Self Tapping Dome 4.8mm x 63mm PH	WP-T10/031

T10 & T11 - SPARE PARTS LIST			v4.0 10/2010
No.	Qty.	Desc.	Ref.
32	1	Fan Baffle	WP-T10/032
35	1	Plunge Lock Lever	WP-T10/035
36	1	Spacer for Revolving Guide	WP-T10/036
37	1	Spring for Plunge Lever	WP-T10/037
38	1	Plunge Lever Bolt	WP-T10/038
40	2	Machine Screw Csk M8 x 35mm Phillips	WP-T10/040
41	1	Handle Left	WP-T10/041
42	1	Lower Bearing Housing T10	WP-T10/042
	1	Lower Bearing Housing T11	WP-T11/042
43	6	Machine Screw Csk M4 x 8mm Phillips	WP-T10/043
44	1	Domed Nut Hex M12	WP-T10/044
45	1	Knurled Nut Outer	WP-T10/045
46	1	Depth Stop	WP-T10/046
47	1	Scale Label	WP-T10/047
48	1	Depth Stop Adjustment Knob	WP-T10/048
49	1	Handle Right	WP-T10/049
50	1	Depth Stop Locking Plate	WP-T10/050
51	1	Depth Stop Locking Knob	WP-T10/051
52	2	Spring for Depth Stop Nut	WP-T10/052
53	1	Washer 6.6mm x 12mm x 1.6mm	WP-T10/053
54	1	Slider for Depth Stop Nut	WP-T10/054
55	1	Bearing 25mm x 47mm x 12mm 6005-2RSLTN9	WP-T10/055
56	1	Spindle Lock Housing	WP-T10/056
57	3	Machine Screw Pan M4 x 8mm Phillips	WP-T10/057
58	1	Bearing Lock Nut	WP-T10/058
59	1	Collet 12mm (Europe)	CLT/T10/12
	1	Collet 12.7mm (UK & Eire)	CLT/T10/127
60	1	Collet Nut	CLT/NUT/T10
61	2	Plunge Spring	WP-T10/061
62	2	Plunge Spring Rod	WP-T10/062
64	1	Spring for Depth Stop	WP-T10/064
65	1	Depth Stop for Micro Adjustment Screw	WP-T10/065
66	1	Machine Screw for Revolving Guide	WP-T10/066
67	1	Threaded Pin M5 x 18mm	WP-T10/067
68	5	Nut Hex M5	WP-T10/068
69	1	Threaded Pin M5 x 22mm	WP-T10/069
70	1	Washer Dished 6.35mm x 12.5mm x 0.5mm	WP-T10/070
71	1	Threaded Pin M5 x 35mm	WP-T10/071
72	1	Revolving Guide	WP-T10/072
73	1	Ball for Revolving Guide	WP-T10/073
74	1	Spring for Revolving Guide	WP-T10/074
78	1	Base Casting Complete T10	WP-T10/078
	1	Base Casting Complete T11	WP-T11/078
79	1	Side Fence Micro Adjuster Scale	WP-T10/079

T10 & T11 - SPARE PARTS LIST			v4.0 10/2010
No.	Qty.	Desc.	Ref.
80	1	Phenolic Slider Base T10	WP-T10/080
	1	Phenolic Slider Base T11	WP-T11/080
81	5	Spring for Thumb Knob	WP-T10/081
82	1	Side Fence Micro Adjuster Screw	WP-T10/082
83	1	Spindle Lock Spring	WP-T10/083
84	1	Guide Rods 10mm x 360mm (Pair)	ROD/10X360
85	5	Thumb Knob Male M6 x 15mm	WP-T10/085
86	2	Side Fence Cheek	WP-T10/086
87	1	Side Fence Complete T10	WP-T10/087
	1	Side Fence Complete T11	WP-T11/087
88	4	Washer 5.5mm x 9.5mm x 1.0mm	WP-T10/088
89	1	Capacitor <10/09	WP-T10/089
	1	Capacitor >10/09	WP-T10/089A
90	4	Washer Spring	WP-T10/090
91	1	Side Fence Bridge with Adjuster T10	WP-T10/091
	1	Side Fence Bridge with Adjuster T11	WP-T11/091
92	1	Spindle Lock Button	WP-T10/092
93	5	Machine Screw Pan M5 x 15mm Phillips	WP-T10/093
94	1	Speed Control Dial	WP-T10E/094
95	2	Machine Screw Csk M5 x 10mm Phillips	WP-T10/095
98	1	Magnet for Speed Control	WP-T10E/098
101	1	Spanner 22mm A/F	SPAN/22
102	1	Side Fence Body	WP-T10/102
103	1	Speed Control Board 115V T10EL & T11EL	WP-T10EL/103
	1	Speed Control Board 230V T10E & T11	WP-T10E/103
104	3	Washer Split Spring M4	WP-T10/104
105	1	Lead Switch to Speed Control (Red x 110mm F-F)	WP-T10/105
106	1	Lead Switch to Speed Control (Red x 105mm M/F-F)	WP-T10/106
107	1	Dust Spout T10	WP-T10/107
	1	Dust Spout T11	WP-T11/107
109	1	Dust Spout Clip	WP-T10/109
110	1	Dust Spout Retaining Clip	WP-T10/110
111	2	Machine Screw Pan M5 x 12mm Slot	WP-SCW/42
112	1	Screw Self Tapping Pan 4mm x 32mm Phillips	WP-T10/112
113	1	Spacer	WP-T10/113
114	0	Armature Kit 115V >10/09 T10EL & T11EL	WP-T10EL/AK
	0	Armature Kit 230V >10/09 T10E & T11E	WP-T10E/AK
117	1	Manual T10 & T11	MANU/T10

T10 & T11 - SPARE PARTS LIST			v4.0 10/2010
No.	Qty.	Desc.	Ref.
118	1	Inner Plate T10	WP-T10/075
	1	Inner Plate T11	WP-T9/075
119	2	Machine Screw Csk M5 x 8mm Slot	WP-SCW/09
120	2	Machine Screw Cheese M5 x 8mm Slot	WP-SCW/98
121	1	Line up Pin 12mm & 1/2"	WP-T9/090
123	1	Guide Bush 30mm x 10mm	GB30/A
FOR T11			
124	1	Stud for Table Height Adjustment T11 <10/05	WP-T11/124
124A	1	Stud for Table Height Adjustment T11 >11/05	WP-T11/124A
125	2	End Cap Hex for Stud T11 <10/05	WP-T11/125
125A	2	End Cap Hex for Stud T11 >10/05	WP-T11/125A
126	1	Barrel Nut for Table Height Adjustment T11	WP-T11/126
127A	2	Hi-tensile 8.8 Machine Screw for Hex Nut >10/05 T11	WP-T11/127A
128	1	Table Fine Height Adjuster T11	WP-T11/128
129	2	Sintered Bush for Table Height Adjustment T11	WP-T11/129
130	0	Stud and Hex Conversion Kit <10/05 to >10/05	WP-T11/130

SERVICE NOTE

FOR T11 PRE-OCT 2005



Pre Oct 2005 T11 Quick Raiser shaft hex nuts are factory set. The bottom (base) hex nut and top hex nut are both permanently glued and tightened to a torque of 22Nm. To remove hex nuts, ensure a socket is used on each end of the shaft. Remove top hex nut first. When servicing the tool, please ensure the correct adhesive and torque setting is used.

FOR T11 POST-OCT 2005



Post Oct 2005 T11 has a splined Quick Raiser shaft and hex nuts. The hex nuts are held by Hi-tensile 8.8 class Torx[®] machine screws which have been permanently glued with Loctite[®] 270 and tightened to torque 2.1Nm to 2.5Nm.

When servicing the tool, please ensure the correct adhesive and torque setting is used.

Please note:



The shaft has been designed to have a 1.2mm float in the sintered bushes.

Please contact Trend Customer Services for further information.

T10 & T11 - SPARE PARTS DIAGRAM

v3.0 11/2009

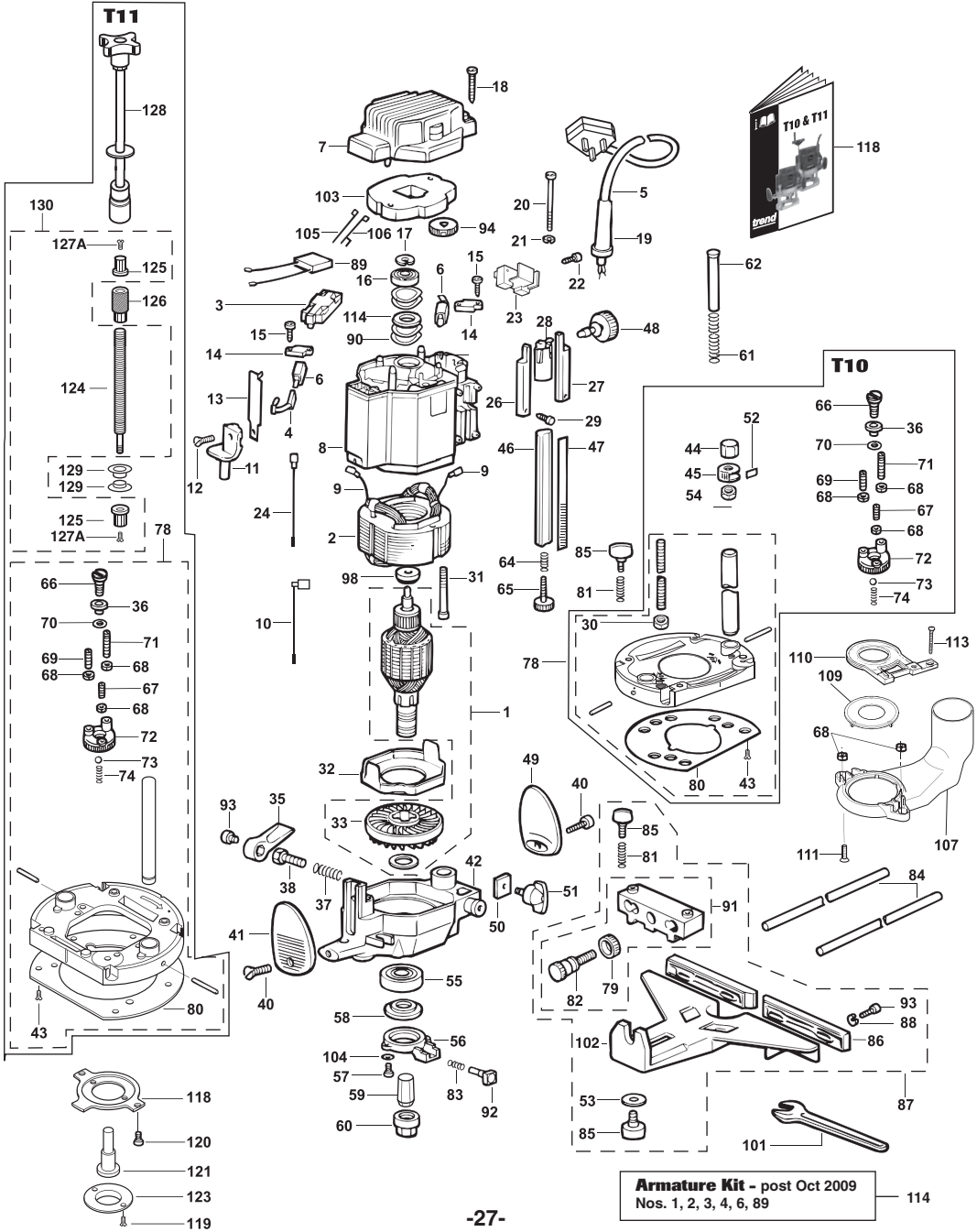

T11 Fine Height Adjuster Fitting Hole Position

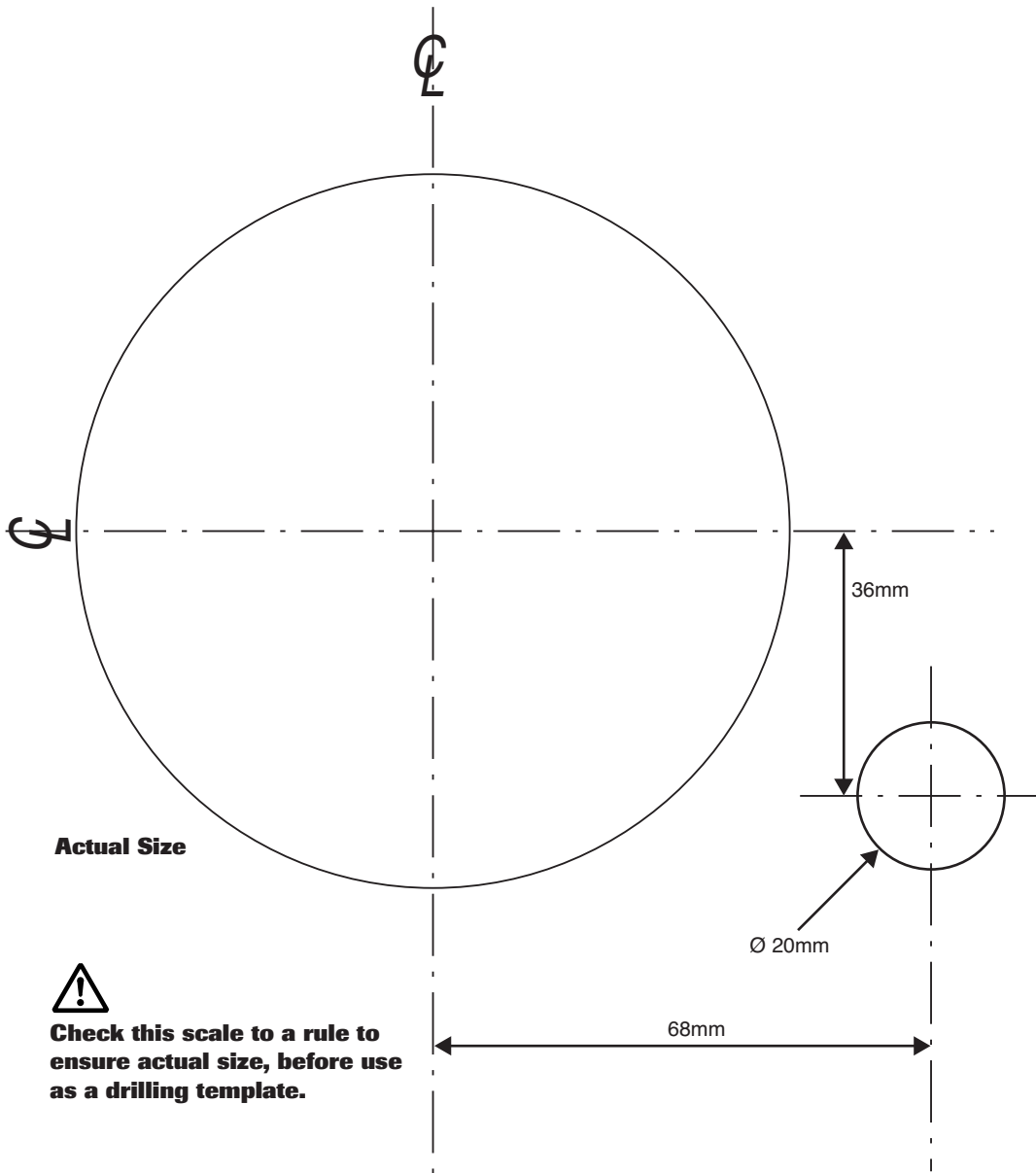

Actual Size



Check this scale to a rule to ensure actual size, before use as a drilling template.

Actual Size

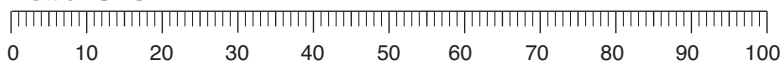

MANU/IT10 v3.1



Trend Machinery & Cutting Tools Ltd.
Odhams Trading Estate St Albans Road
Watford WD24 7TR England
Tel: 0044(0)1923 249911
technical@trendm.co.uk
www.trend-uk.com