



# SRT



**trend**<sup>®</sup>  
routing technology

Dear Customer

Thank you for purchasing this Trend product, we hope you enjoy many years of creative and productive use.

Please remember to return your guarantee card within 28 days of purchase.

## CONTENTS

<b>TECHNICAL DATA</b>	<b>1</b>
<b>MANUFACTURERS DECLARATION</b>	<b>1</b>
<b>SAFETY</b>	<b>2-3</b>
<b>ELECTRICAL SAFETY</b>	<b>4</b>
<b>ITEMS ENCLOSED</b>	<b>5</b>
<b>DESCRIPTION OF PARTS</b>	<b>6</b>
<b>ASSEMBLY</b>	
– Fitting Legs	7
– Fitting Switch	8
– Fitting Scaled Label	9
– Router Compatibility	10
– Screw Selection & Re-drilling	11
– Fitting Dust Spout to Back Fence	12
– Fitting Insert Rings & Top Pressure	13-14
– Fitting Back Fence & Top Guard	15-16
– Fitting Side Pressure & Mitre Fence	17-18
– Bench Fixing & Dust Extraction	19-20
<b>OPERATION</b>	
– No-Volt Release Switch	21
– Back Fence Adjustment	22
– Edge Moulding and Grooving	23
– Stopped Moulding	24
– Edge Planing	25
– Mitre Fence	26
– Lead-on Pin	27
<b>MAINTENANCE</b>	<b>28</b>
<b>RECYCLING</b>	<b>28</b>
<b>GUARANTEE</b>	<b>28</b>
<b>SPARE PARTS</b>	
– Spare Parts List	29-30
– Spare Parts Diagram	31



If you require further technical information or spare parts, please call our technical support department on 01923 224681.

## TECHNICAL DATA

Voltage:	UK & Eire	240V
	Europe	230V
On/off switch		No-volt release
Dimensions (width x depth)		610mm x 355mm
Height with legs		357mm
Cutter diameter max.		50mm
Loss of cutting depth due to table thickness		3.2mm
Weight		8.7kg
Fuse:	UK & Eire	240V 13A in plug
	Europe	230V 10A in mains

The following symbols are used throughout this manual:



Denotes risk of personal injury, loss of life or damage to the tool in case of non-observance of the instructions in this manual.



Denotes risk of electric shock.



Refer to the instruction manual of your power tool.

## MANUFACTURERS DECLARATION



We declare that the attachment mentioned above has been designed in accordance with 73/23/EEC.

This unit must not be put into service until it has been established that the power tool to be connected to this unit is in compliance with 98/37/EC (identified by the CE marking on the power tool).

*S J Phillips*

Managing Director  
Stephen Phillips

Trend Machinery & Cutting Tools Ltd.

### Intended Use

The unit is intended for stationary operation of routers.

### SAFETY



Observe the safety regulations in the instruction manual of the Power Tool to be used or connected to this attachment. Also observe any applicable additional safety rules. Read the following safety instructions before attempting to operate this product.

#### PLEASE KEEP THESE INSTRUCTIONS IN A SAFE PLACE.

The attention of UK users is drawn to The Provision and Use of Work Equipment Regulations 1998, and any subsequent amendments.

#### General

- Disconnect power tool, when not in use. Before servicing and when changing accessories such as cutters. Disconnect power tool and attachment from power supply. Ensure the machine is switched off before plugging tool in or connecting to a power supply.
- Always mount the power tool, accessory or attachment in conformity with the present instructions.
- Keep children and visitors away. Do not let children or visitors touch the tool, accessory or attachment. Keep children and visitors away from work area.
- Make the workshop child proof with padlock and master switch.
- Dress properly. Do not wear loose clothing or jewellery, they can be caught in moving parts. Rubber gloves and non-skid footwear is recommended when working outdoors. Wear protective hair covering to contain long hair.
- Consider working environment. Do not use the product in the rain or in a damp environment. Keep work area well lit. Do not use power tools near gasoline or flammable liquids. Keep workshop at a comfortable temperature so your hands are not cold.
- The accessory or attachment must be kept level and stable at all times.
- Keep work area clean. Cluttered workshops and benches can cause injuries
- Use the attachment with the power tools and accessories specified in this manual only. Do not force the tool or attachment to do a job for which it is not designed.
- Secure idle tools. When not in use, tools should be stored in a dry and high or locked up place, out of reach of children.
- For best control and safety use both hands on the power tool and attachment. Keep both hands away from cutting area. Always wait for the spindle and cutter to stop rotating before making any adjustments.
- Always keep guards in place and in good working order.
- Remove any nails, staples and other metal parts from the workpiece.
- Maintain tools and cutters with care. Keep cutters sharp and clean for better and safer performance. Do not use damaged cutters. Follow instructions for lubricating and changing accessories. Keep handles dry, clean and free from oil and grease.
- Maintain accessories. Do not use damaged accessories. Only use accessories recommended by the manufacturer.
- Check damaged parts. Before operation inspect the attachment, the power tool, the cable, extension cable and the plug carefully for signs of damage. Check for alignment of moving parts, binding, breakage, mounting and any other conditions that may effect its operation. Have any damage repaired by an Authorised Service Agent before using the tool or accessory.
- Do not use tool if switch does not turn it on or off. Have defective switches replaced by an Authorised Service Agent.
- Don't over reach. Keep proper footing and balance at all times.
- Don't abuse the cable. Never carry power tool or accessory by cord or pull it to disconnect from the socket. Keep cord from heat, oil and sharp edges. Always trail the power cord away from the work area.
- Connect dust extraction equipment. If devices are provided for the connection of dust extraction and collection facilities, ensure these are connected and properly used.
- Check all fixing and fastening nuts, bolts and screws before use to ensure they are tight and secure. Periodically check when machining over long periods.
- Stay alert. Watch what you are doing. Use common sense. Do not operate tools when you are tired, under the influence of drugs or alcohol.
- Personal Protective Equipment (PPE). All PPE must meet current UK and EU legislation.
- Do not leave tools running unattended. Do not leave tool until it comes to a complete stop.
- Always clamp workpiece being machined securely.
- Only use cutting tools for woodworking that meet EN847-1/2 safety standards, and any subsequent amendments.

#### Routing Safety

- Disconnect router power tool. When not in use, before servicing and when changing accessories such as cutters, disconnect router and attachment from power supply.
- Ensure router cutter has stopped rotating before changing it. Never use the spindle lock as a brake.
- Remove adjusting keys and spanners. Form the habit of checking to see that keys and adjusting spanners are removed from the router tool, cutter and attachment before turning router on. Make sure cutter can rotate freely.
- Check all ball bearing and blade fixing screws before use to ensure they are tight and secure. Periodically check when machining over long periods.
- When using a template guide bush ensure it cannot come into contact with collet and nut.
- Noise. Take appropriate measures for the protection of hearing if the sound pressure of 85dB(A) is exceeded. Routing sound pressure may exceed 85dB(A), so ear protection must be worn.

- Eye protection. Wear safety goggles, spectacles or visors to protect the eyes from ejected waster particles.
- Respiratory protection. Wear a face or dust mask, or powered respirator. Dust masks/filters should be changed regularly.
- Do not switch router on with the cutter touching the workpiece.
- The direction of routing must always be opposite to the cutter's direction of rotation.
- After work, release the router plunge and allow spindle to stop rotating before putting machine down.
- Check before cutting that there are no obstructions in the path of the router. When cutting through the full thickness of the workpiece, ensure there are no obstacles beneath workpiece, and that a sacrificial work surface is used.

#### **Additional Safety Rules For Router Cutters**

- Cutting tools are sharp. Care should be taken when handling them.
- Always use cutters with a shank diameter corresponding to the size of the collet installed in your tool.
- Always run router cutters at the spindle speed recommended and marked accordingly. Ensure cutter has reached correct speed before entering workpiece. Recommended speeds can be found on the packaging, in cutter instructions or in the Trend Routing Catalogue.
- Always use router cutters in a router. Router cutters must not be used in a drill. Drill and boring bits must not be used in a router. Router cutters must only be used for the material cutting application for which they are designed. Do not use on metal or masonry.
- Never use cutters with a diameter exceeding the maximum diameter indicated in the technical data of the powertool or attachment used.
- Do not drop cutters or knock them against hard objects. Do not use cutters that are damaged.
- Cutters should be kept clean. Resin build up should be removed at regular intervals with Resin Cleaner<sup>®</sup>. The use of a dry lubricant (Trendicote<sup>®</sup> PTFE) will act as a preventative. Do not use PTFE spray on plastic parts.
- Cutter shanks should be inserted into the collet to the mark line on the shank. This ensures that at least  $\frac{3}{4}$  of the shank length is held in the collet. Do not over-tighten the collet nut as this will score the shank and create a weakness and fracture point.
- Observe the correct assembly instructions in the router instruction manual for fitting the collet and nut. Observe the router power tool manual instructions on fitting cutters correctly.
- It is advisable to periodically check the collet and collet nut. A worn, distorted or damaged collet can cause vibration and damage the shank, and should be replaced. Worn collet nuts should be replaced.
- Do not take deep cuts in one pass: take several shallow or light passes to reduce the side load applied to the cutter. Too deep a cut in one pass can stall the router.
- Very small diameter cutters must be handled and used with care.
- Always return cutter to its packaging after use.
- Should you experience excessive vibration during use stop immediately. Have the eccentricity of the router, router cutter and clamping system checked.
- All fastening screws and nuts should be tightened using the appropriate spanner or key in accordance with the manufacturers instructions.

#### **Using Routers In A Fixed Position**

- After work, release the router plunge to protect the cutter.
- Always use a push-stick or push-block for last 300mm of the cut.
- Whenever possible use a work holding device or jig to secure component being machined.
- Ensure attachment is securely fitted to the workbench, with table surface at approximately hip height.
- Ensure a No-Volt Release Switch is

fixed to or adjacent to the attachment and that it is used correctly.

- Check the direction of the workpiece is always opposite to the cutter's direction of rotation.
- Do not use awkward or uncomfortable hand positions.
- Do not reach underneath table or put your hands or fingers at any time in the cutting path while tool is connected to a power supply.

#### **Useful Advice When Routing**

- Judge your feed rate by the sound of the motor. Feed the router at a constant feed rate. Too slow a feed rate will result in burning.
- Take many light passes rather than one deep cut to reduce the side load applied to both router and router cutter.
- Trial cuts should be made on waste material before starting any project.
- When using some attachments including a router table or dovetail jig, the use of a fine height adjuster is highly recommended.
- When using a template guide bush, ensure there is sufficient clearance between cutter tip and inside each of bush. Ensure cutter and guide bush are concentric.

#### **Router Cutter Maintenance**

- Composite cutting tools (brazed tip) must be maintained by a competent person i.e. a person of training and experience, who has knowledge of the design requirements and understands the levels of safety to be achieved.
- The design of composite tools must not be changed in the process of maintenance.
- Replacement parts must meet Trend specification.
- Tolerances which ensure correct clamping by the collet shall be maintained.
- When re-grinding the tool, care must be taken not to cause weakening of the body or the connection between the cutting edge and the body.

**ELECTRICAL SAFETY**

**Mains Plug Replacement  
(UK & Ireland only)**

Always check the condition of the cable and plug before starting with your work.

Should your mains plug need replacing and you are competent to do this, proceed as instructed below. If you are in doubt, contact an authorised Trend repair agent or a qualified electrician.

- Disconnect the plug from the supply.
- Cut off the plug and dispose of it safely; a plug with bared copper conductors is dangerous if engaged in a live socket outlet.
- Only fit 13 Amperes BS 1363A approved plugs fitted with a 13 Amp A.S.T.A approved BS 1362 fuse (1).
- The cable wire colours, or a letter, will be marked at the connection points of most good quality plugs. Attach the wires to their respective points in the plug (see below). Brown is for Live (L) (2) and Blue is for Neutral (N) (3).
- Before replacing the top cover of the mains plug ensure that the cable restraint (4) is holding the outer sheath of the cable firmly and that the two leads are correctly fixed at the terminal screws.

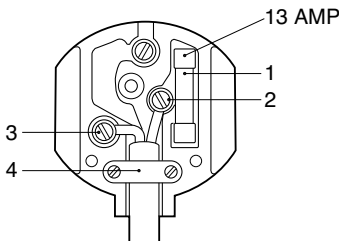
**Never use a light socket.**

**Never connect the live (L) or neutral (N) wires to the earth pin marked E or  $\perp$ .**

**Using an Extension Cable**

- If an extension cable is required, use an approved triple core extension cable suitable for the power input of this tool (see technical data). The minimum conductor size is 1.5mm.
- When using a cable reel, always unwind the cable completely.
- Also refer to the table below.

Cable Rating (Amperes)	
Voltage 240V	
7.5	6A
15	6A
25	6A
30	6A
45	10A
60	15A

  

Cable Length (m)	Conductor size (mm <sup>2</sup> )	Cable rating (Amperes)
	0.75	6
1.00	10	
1.50	15	
2.50	20	
4.00	25	



**DESCRIPTION  
OF PARTS**

- ① Table top
- ② Legs
- ③ Insert plate
- ④ Back fence
- ⑤ No-volt release switch
- ⑥ Dust spout
- ⑦ Side pressure guard
- ⑧ Top pressure guard
- ⑨ Fence cheek stepper
- ⑩ Top guard
- ⑪ Mitre fence
- ⑫ Lead-on pin
- ⑬ Insert ring
- ⑭ T-handle hex key 4mm
- ⑮ Hex key 3mm

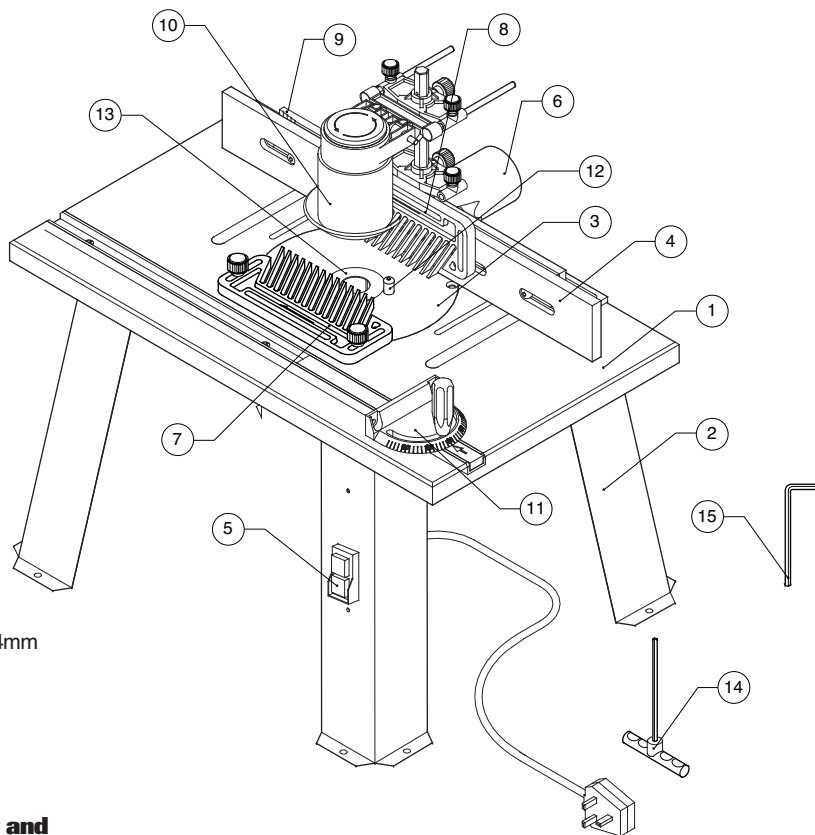

**Prior to assembly and  
adjustment always  
unplug the router table.**

**ASSEMBLY**  
**Fitting Legs**

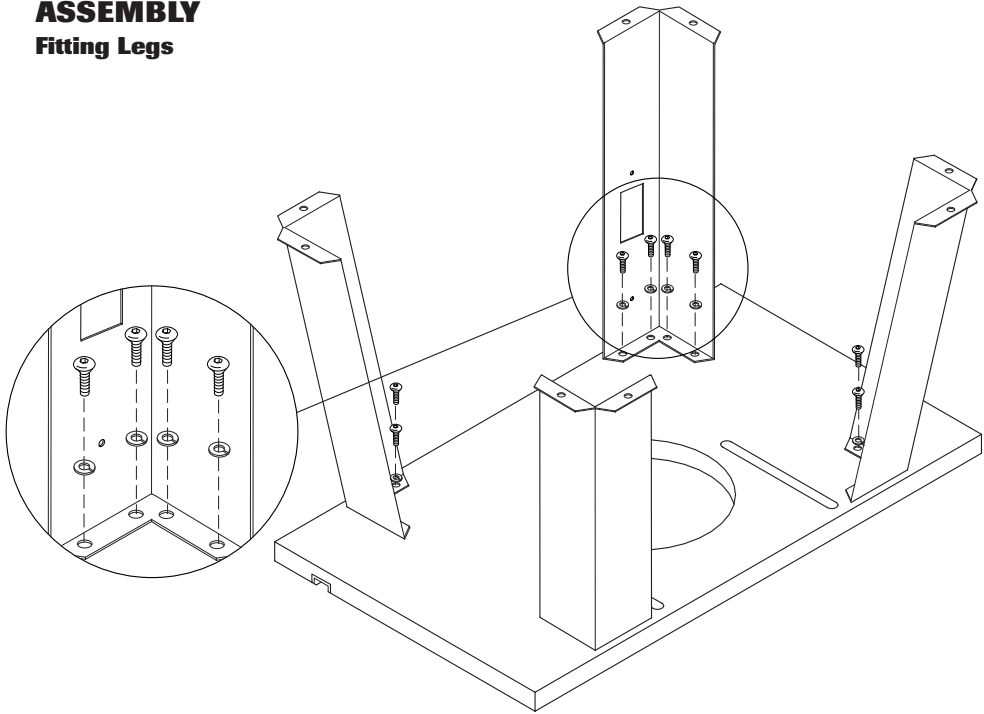

**Identify Parts**

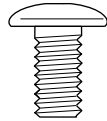

**x 16**



**x 16**

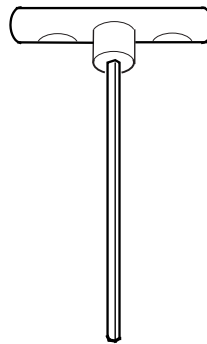



**Fitting Switch**

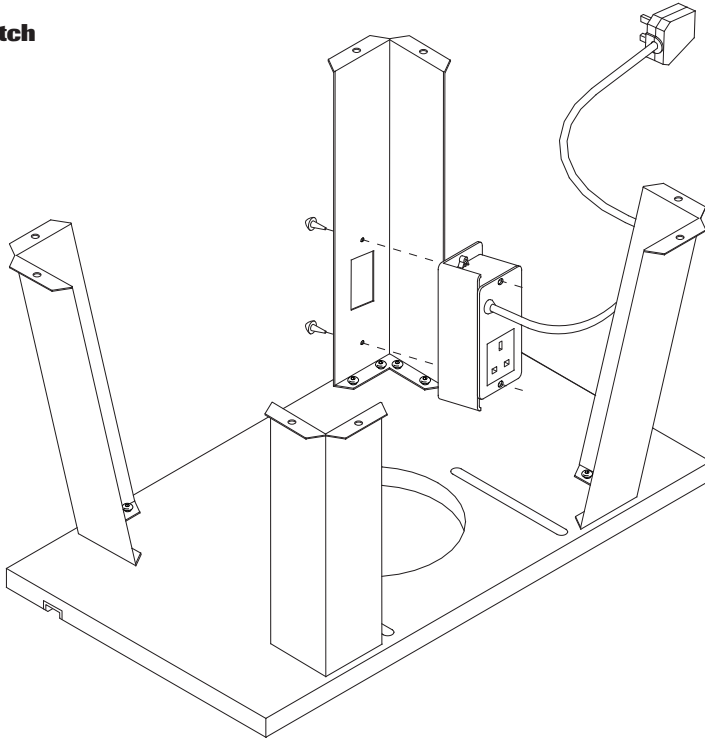

**Requires:  
No 1 Phillips<sup>®</sup>  
Screwdriver  
(not supplied).**

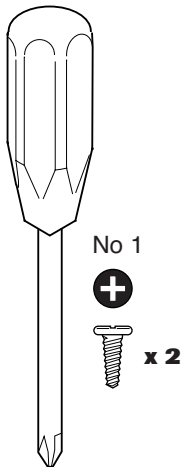

**Fitting Scaled  
Label**

Apply the labels with  
the zero lining up with  
the centre line on the  
insert plate.

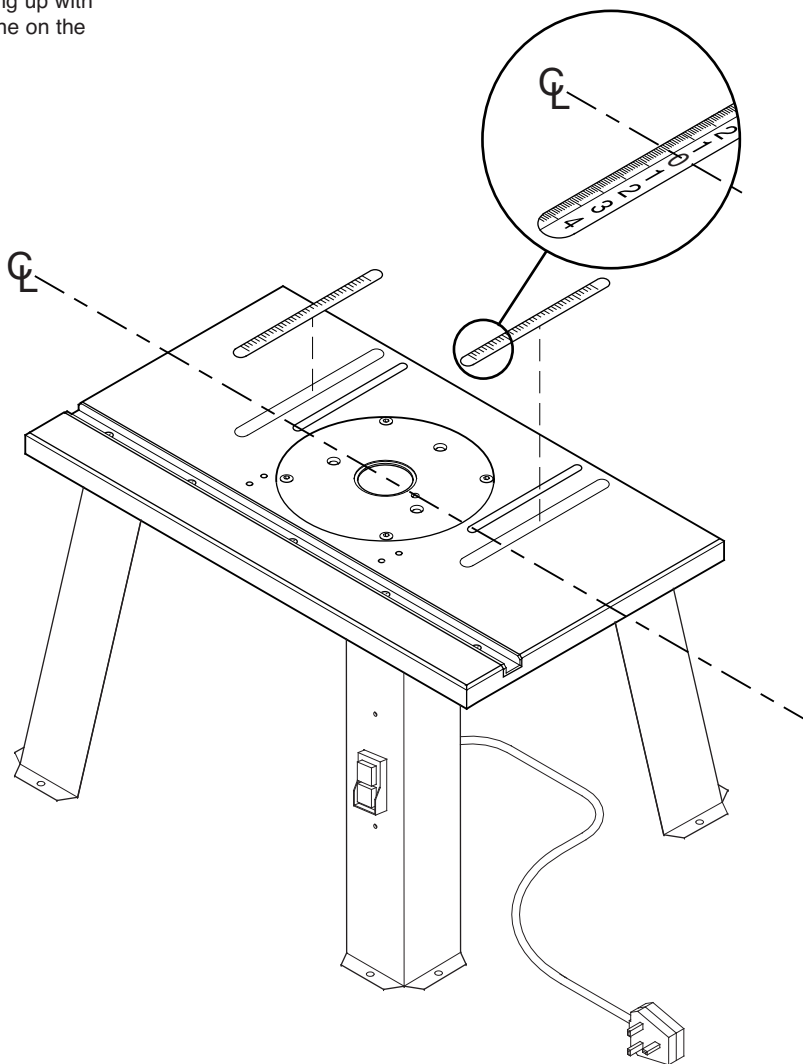

**Router Compatibility** See machine screw illustrations on opposite page.

Three machine screws (F) are supplied as standard with the SRT table

Make	Router Model	Screw x Qty
TREND	T3, T5, T5 MK2	F X 2
DEWALT	DW613, 614, 615	F X 2
DRAPER	PT1200V	F X 2
ELU	MOF96(E) MK2	F X 2
MAKITA	RP0910, 1110C	F X 2
PERLES	OF808(E) >1999, OF2-808(E)	F X 2



The following machines require a machine screw pack accessory ref. FIX/KIT/2 (not supplied with table)

Make	Router Model	Screw x Qty	Csk Size & Hole
AEG	OF450S■, 500S■, OFSE850■, OFS50■	G X 2	13mm X 6mm
AXMINSTER	AW635R■	G X 2	13mm X 6mm
ATLAS COPCO	OFS720■, OFSE850■, 1000■, OFS50■, OFE710■	G X 2	13mm X 6mm
B&D	KW779■, 780(E)■, BD780(E)■, 800(E)■	A X 3	9.5mm X 4mm
B&D	SR100■, DN67■, BD66■	G X 2	13mm X 6mm
BOSCH	POF400■+, 500A■+, 600ACE■+, 800A■	F X 2	13mm X 6mm
BOSCH	GOF900ACE■, 1300A■	H X 3	13mm X 6mm
CASALS	FT750■, 1000E■	F X 3	13mm X 6mm
CHAMPION	CPR850■	G X 2	13mm X 6mm
CK LEKTRO	LRT700■+	F X 2	13mm X 6mm
DRAPER	R850V■	G X 2	13mm X 6mm
EINHELL	EOF850SP■	G X 2	13mm X 6mm
ELU	MOF96(E) MK1■	G X 2	13mm X 6mm
FELISATTI	TP245(E)■	G X 2	13mm X 6mm
FERM	FBF-6E■, FBF-8E■	G X 2	13mm X 6mm
FESTO	OF900(E)■, 1000(E)■, 1010EB■,	G X 2	13mm X 6mm
FREUD	FT1000E■	F X 3	13mm X 6mm
HITACHI	FM8■, ZK2008■	G X 2	13mm X 6mm
HITACHI	M8(V)■	B X 4	10mm X 5mm
HOLZHER	2335■, 2355■, 2356■	G X 2	13mm X 6mm
JCBP	PR■	G X 2	13mm X 6mm
KANGO	R8550S■	G X 2	13mm X 6mm
KRESS	FM6955■	G X 2	13mm X 6mm
LYNX	RT-800-A■+	G X 2	13mm X 6mm
MAFELL	LO50E■	G X 2	13mm X 6mm
MAKITA	3620■,	D X 2	10mm X 5mm
METABO	OF528■, 1028■, OFE1229■	G X 2	13mm X 6mm
MILWAUKEE	OFSE1000■	G X 2	13mm X 6mm
NUTOOL	NPT850■	G X 2	13mm X 6mm
PERLES	OF808(E) <1998■	G X 2	13mm X 6mm
PEUGEOT	DF55E■, DEF570E■	B X 2	10mm X 5mm
POWER DEVIL	PDW5026■, 5027■	G X 2	13mm X 6mm
PERFORMANCE POWER	1020W■	G X 2	13mm X 6mm
POWERBASE	1020W■	G X 2	13mm X 6mm
RYOBI	RE120■, R150■, R151■, RE155K■	D X 2	10mm X 5mm
SKIL	1835■	C X 3	10mm X 5mm
SPARKY	X52E■	G X 2	13mm X 6mm
STAYER	PR50V■	G X 2	13mm X 6mm
VIRUTEX	FR77C■, 78C■, 66F■	H X 2	13mm X 6mm
WICKES	900W■	G X 2	13mm X 6mm

- Re-drilling of router base by user required.
- Re-drilling of insert plate by user required.
- + Packing piece 3mm thick required.

**Do not mount any power tools  
not specified on this list.**

### Screw Selection

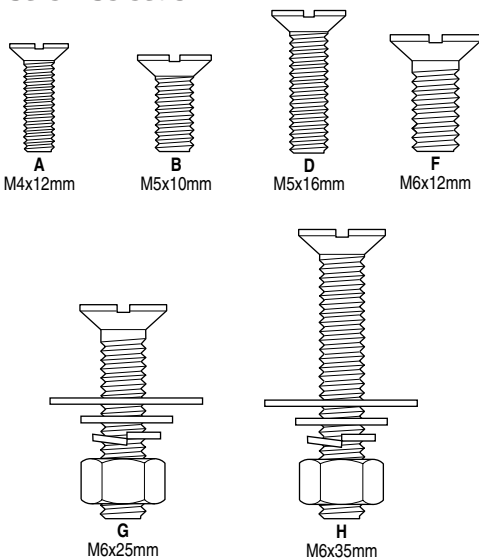

### Mounting Router to Insert Plate

Screws are supplied for TBC routers, see opposite chart. For other makes of router, re-drilling of the router base or insert plate will be required. Appropriate machine screws will be required, see chart.

### Re-drilling Router Base Only

- Invert and stand your router onto a suitable surface.
- Place the fixing plate facing upwards onto the base of your router.
- Adjust position of the fixing plate to centralise.
- Ensure that the holes you are about to drill in the base do not interfere with any of the features on the router or any webbing in the casting of the router base. A slight turning of the plate may be required to miss such obstructions.
- Mark the centre of the holes onto the base.
- Remove plate and mark the centre of the holes with a centre punch.
- Drill a hole at these points with a 6mm diameter drill bit.
- Clean up edges of holes if required.

### Re-drilling Fixing Plate Only

- Remove the plastic base of the router. Alternatively a photocopy or an outline of the base can be made of the plastic base instead.
- Align the centre of the fixing plate to the router base and secure them together.
- Using a centre punch, mark the centres of holes.
- Drill the required hole size with a suitable metal cutting drill bit. Best results will be obtained if your power drill is mounted in a drill stand.
- Countersink the hole with a countersink bit to a depth so the heads of the screws are slightly below the top surface. Clean off any burrs created.

### Re-drilling both Fixing Plate and Router Base

- Invert the router and lay the fixing plate onto the upturned base.
- Clamp the fixing plate and router base together with two cramps.
- Ensuring that the drill bit will not foul any webbing or fixtures on the router base, drill with a 6mm diameter metal cutting drill bit into the fixing plate and through the router base two holes approximately 75mm apart.
- Unclamp the router base and fixing plate.
- Countersink the fixing plate holes with a countersink bit to a depth so the screw heads are slightly below the top surface. Clean off any burrs created on both the fixing plate and router base.

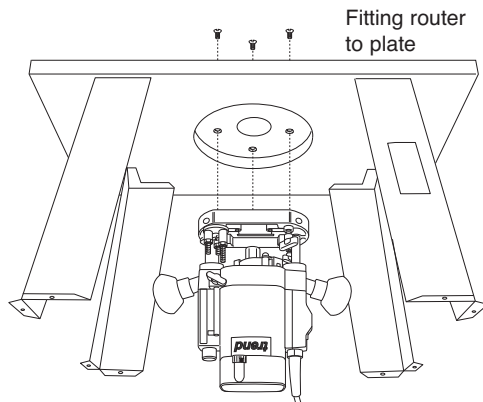

**Fitting Dust Spout  
to Back Fence**

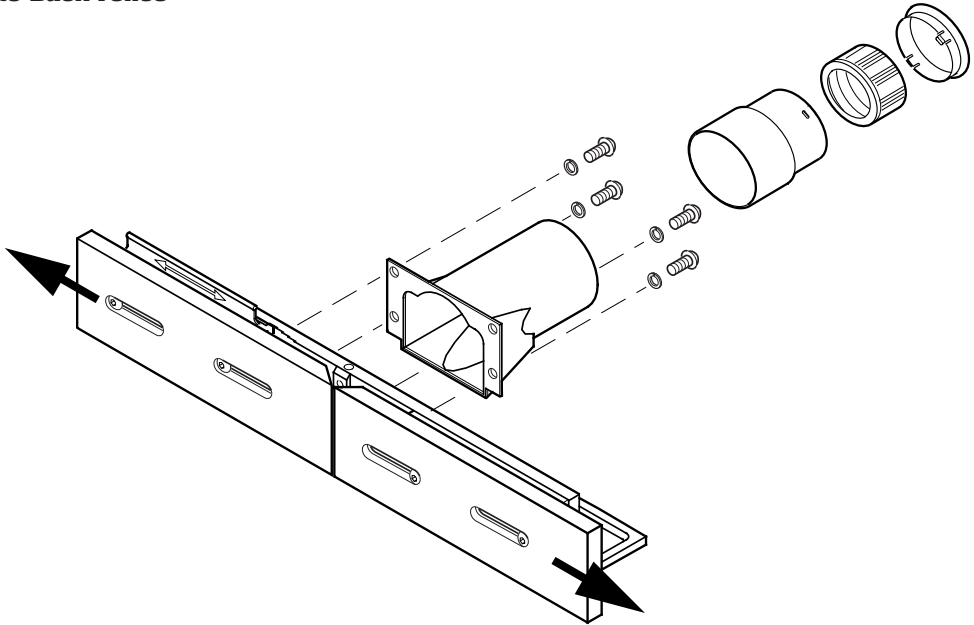

**Identify Parts**

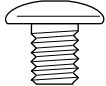

**x 4**



**x 4**

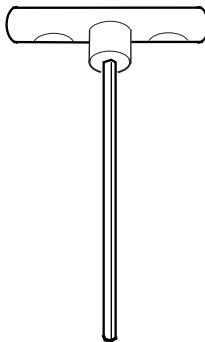

**Fitting Insert Rings**

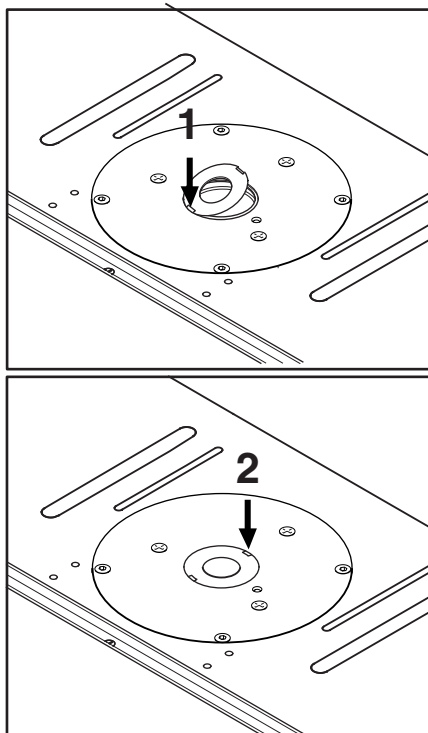
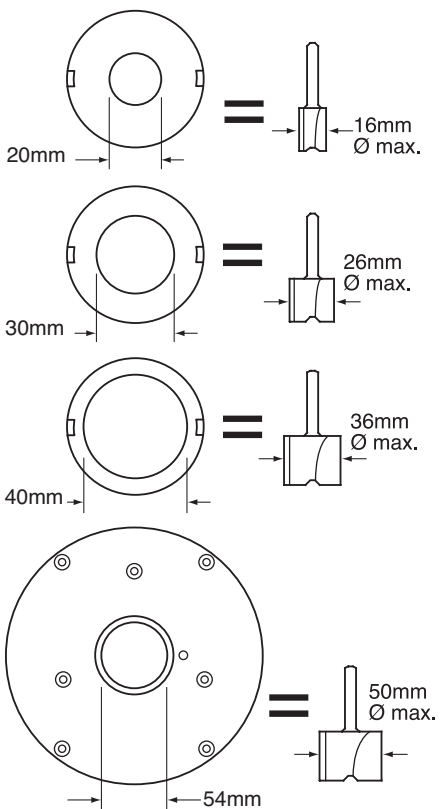
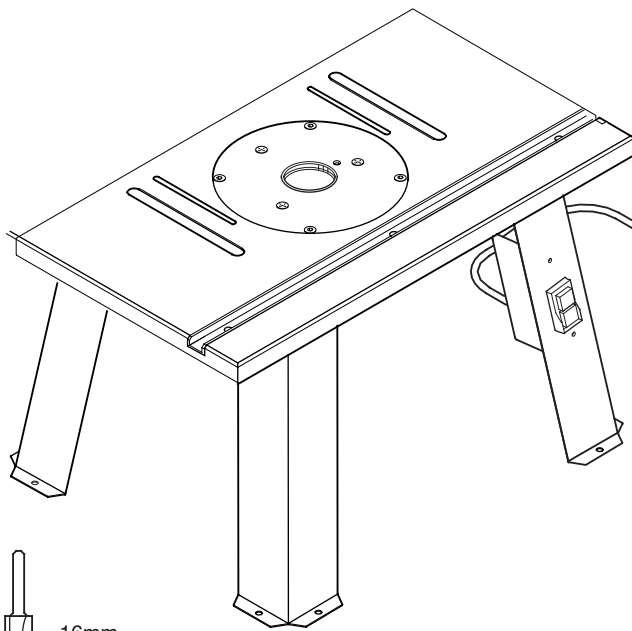

**Fitting Top Pressure**

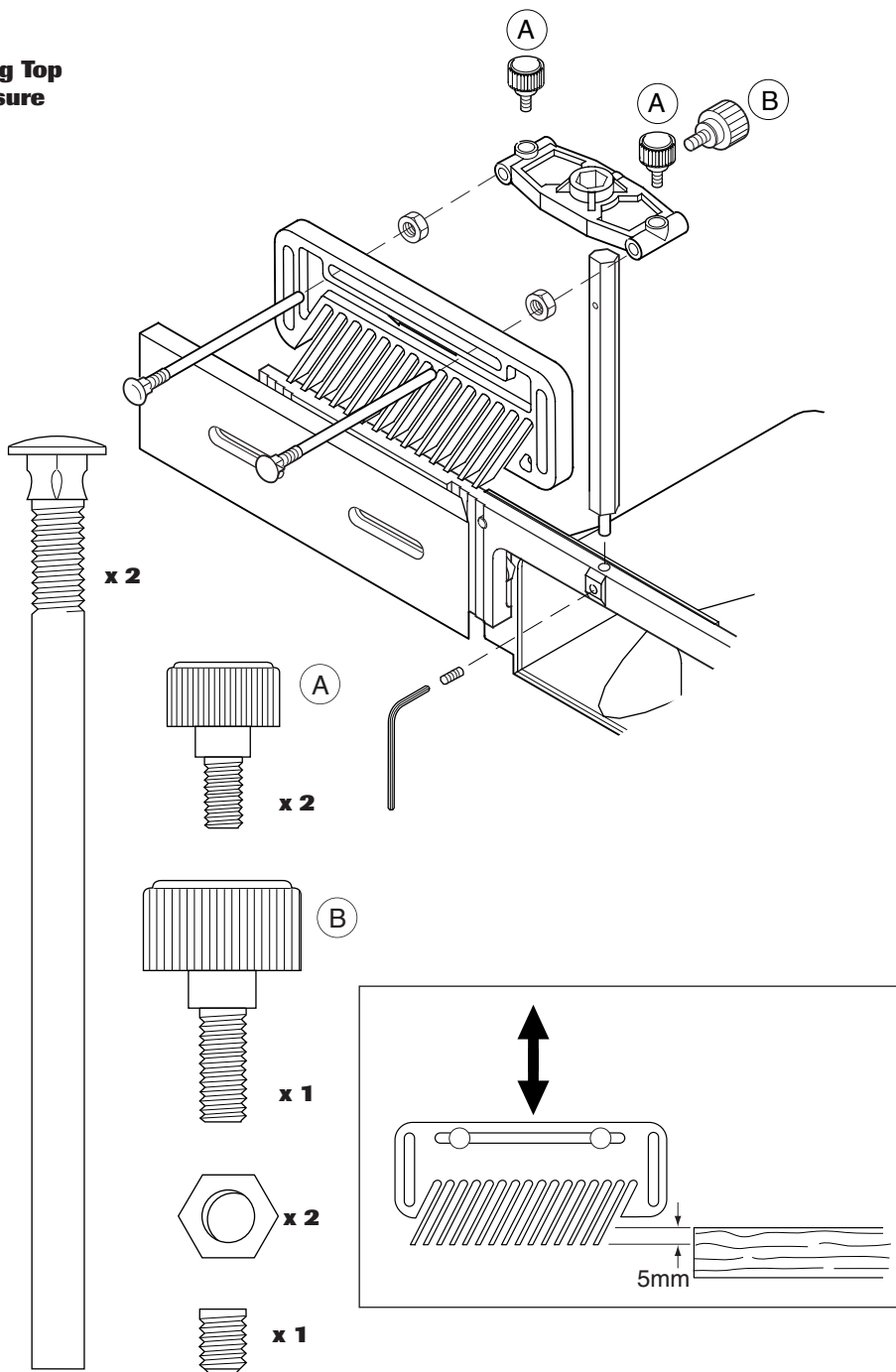

**Fitting Back Fence**

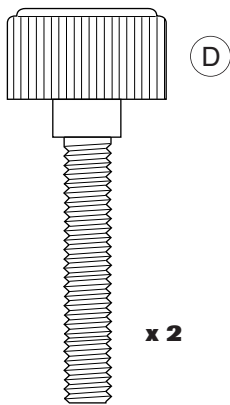
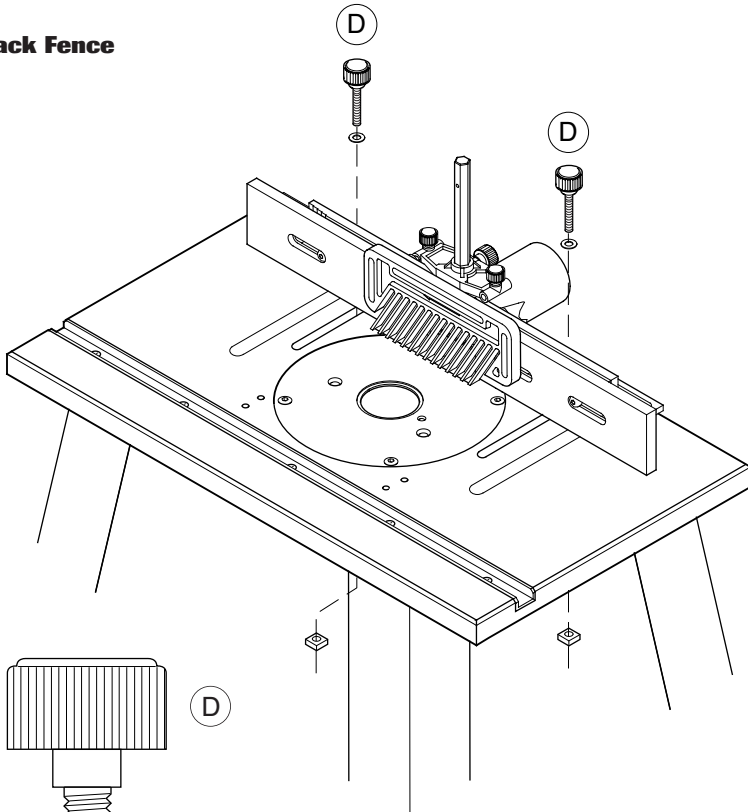

**x 2**



**x 2**

**Plastic**



**x 2**

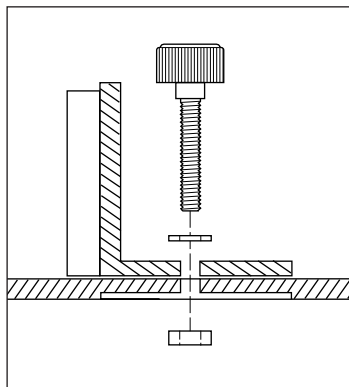



**Fitting Top Guard**

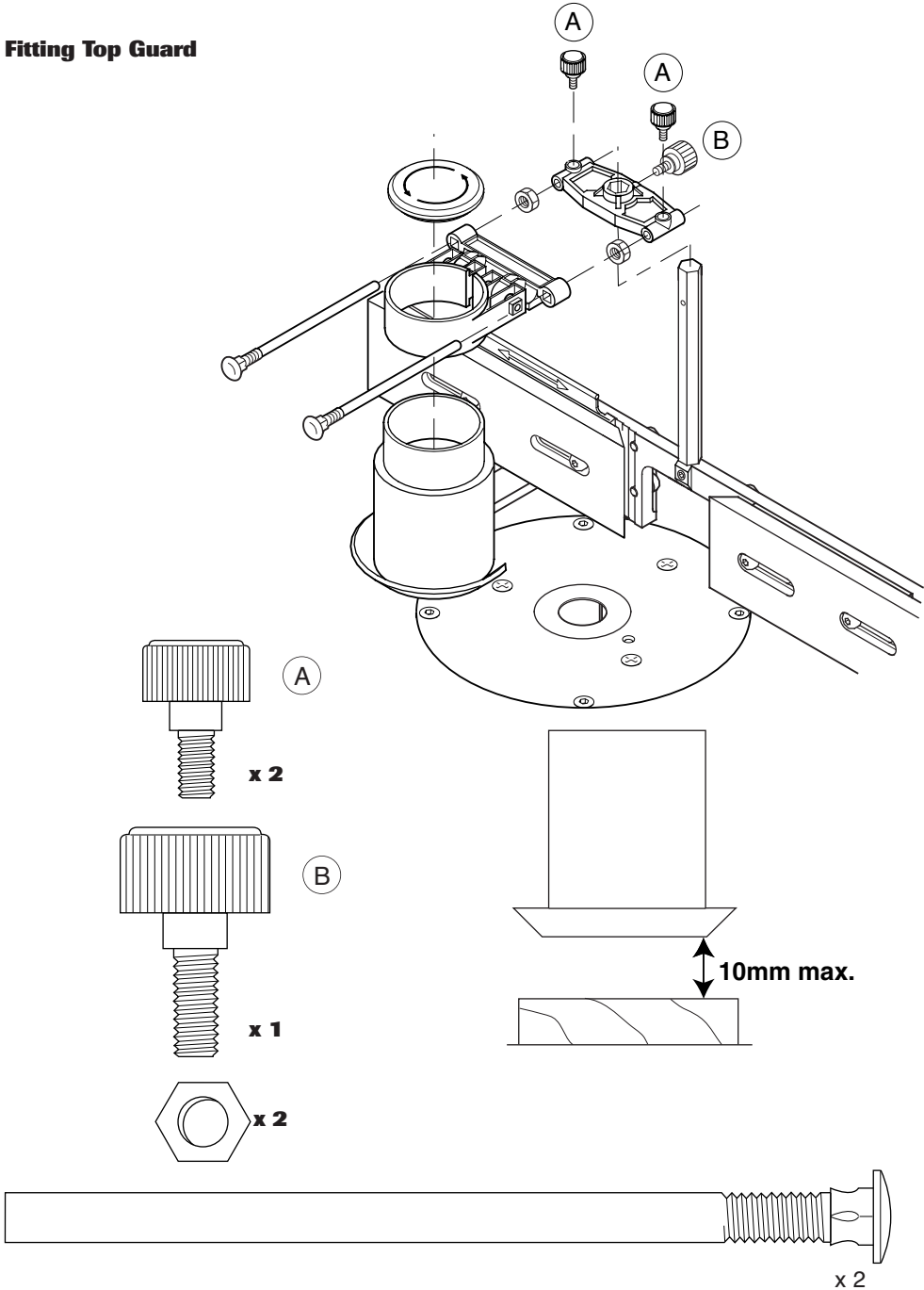

**Fitting Side Pressure**

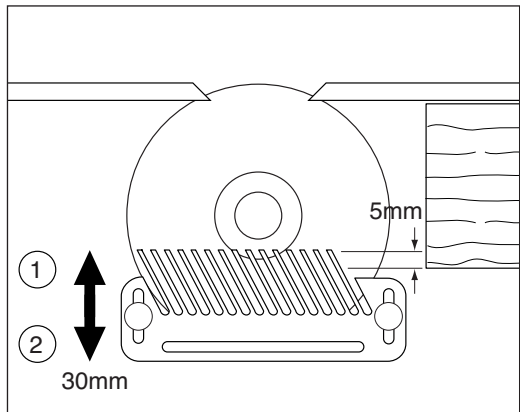
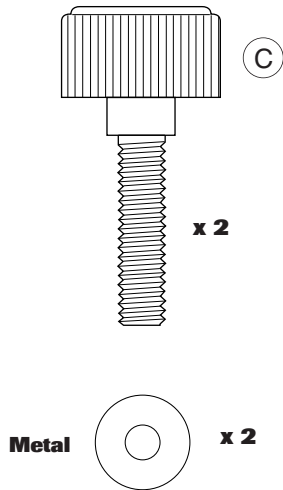
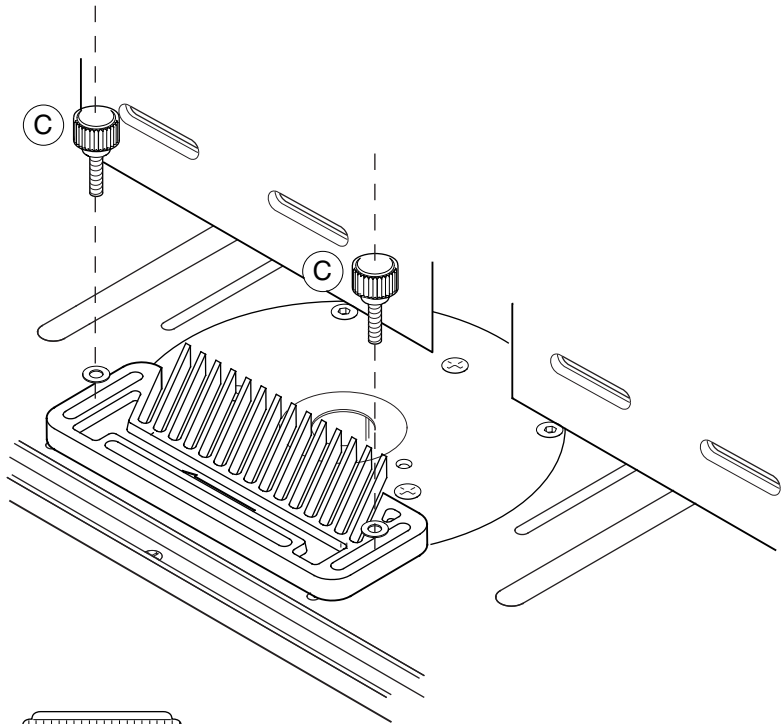

**Fitting Mitre Fence**

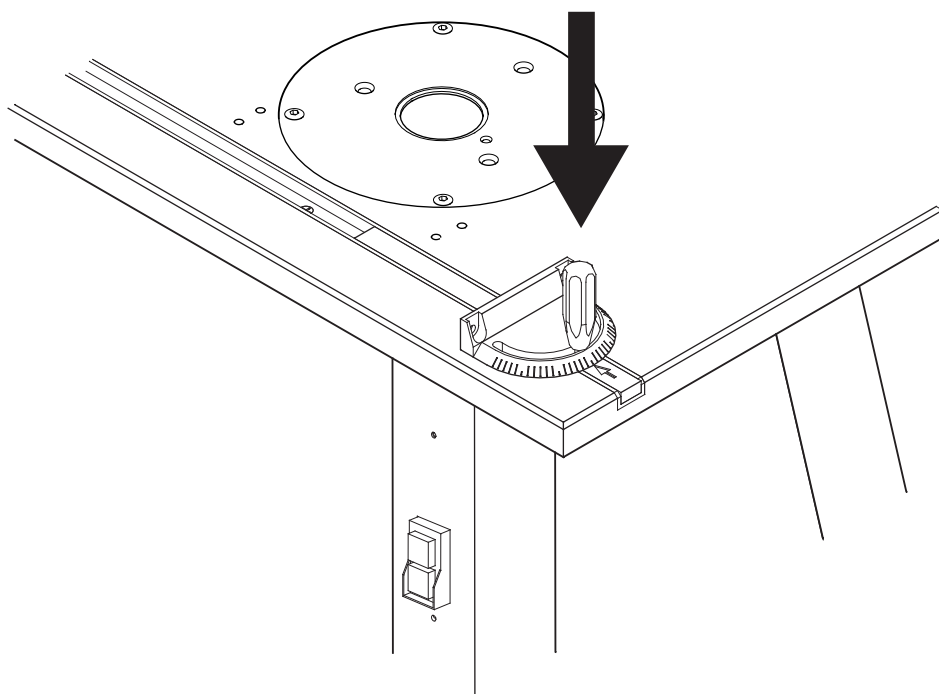

**Bench Fixing** 

Fix the router table to the workbench or workboard with eight No.8 x 3/4" pan head screws (not supplied).

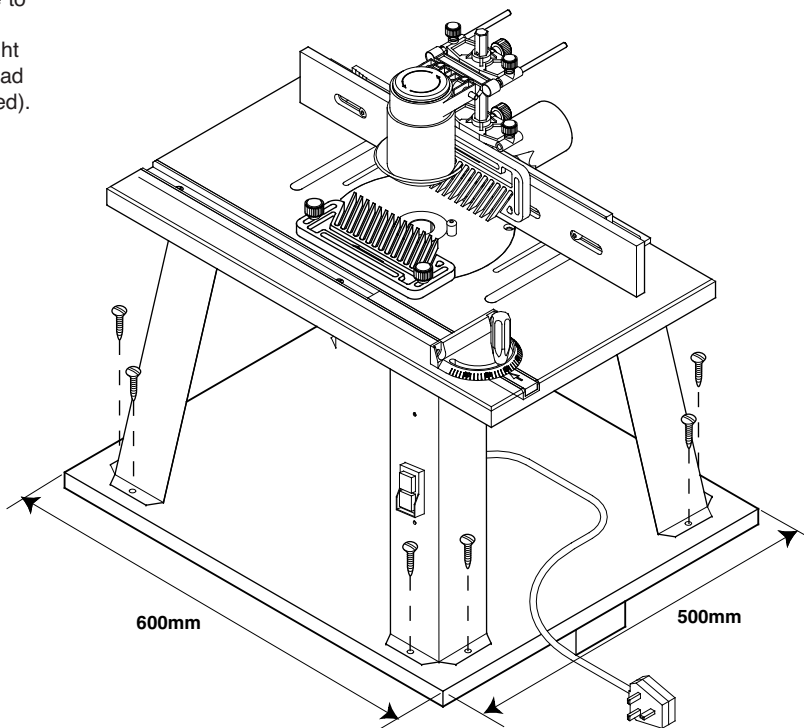

**Dust Extraction -  
Fitting Hose**

Hose Ref: T30/22 or  
CRT/4 not included.

**Option 1**

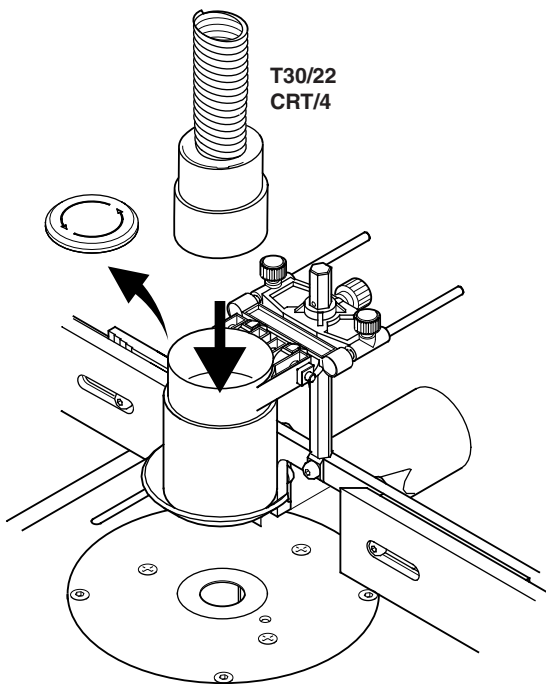

**Option 2**

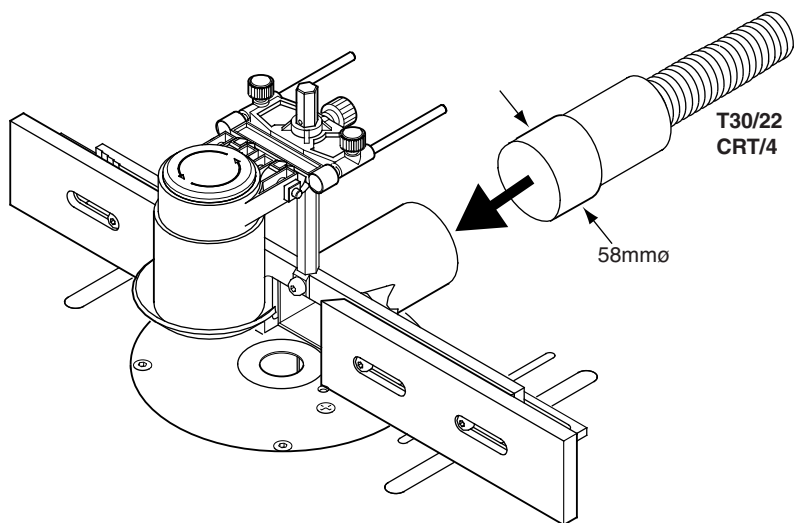

**OPERATION**

**No-Volt Release Switch**

- 1 Plug machine into socket in no-volt release switch.
- 2 Put plug of switch into mains supply.
- 3 Switch on router
- 4 Press green button to switch on. To switch off press red button.

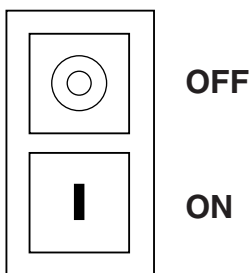
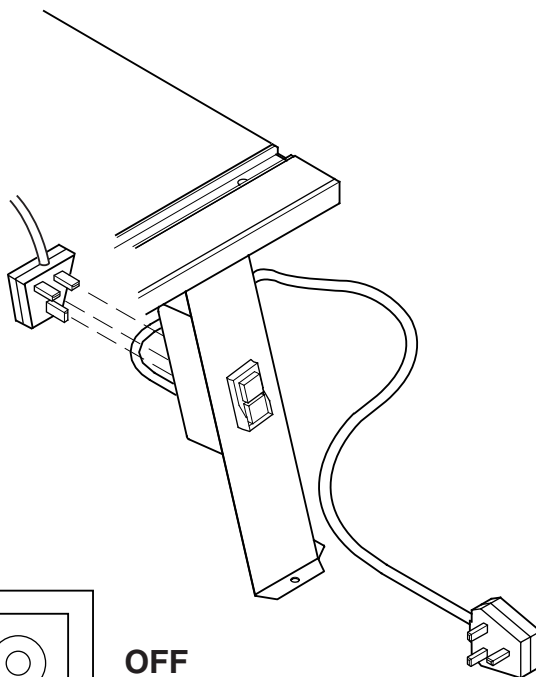

**Isolate from power supply when making any adjustments.**

**Back Fence Adjustment**



- 1 Adjust back fence position by loosening two knobs (A) and pushing fence forwards or backwards.
- 2 Lock fence position by tightening the two knobs (A).

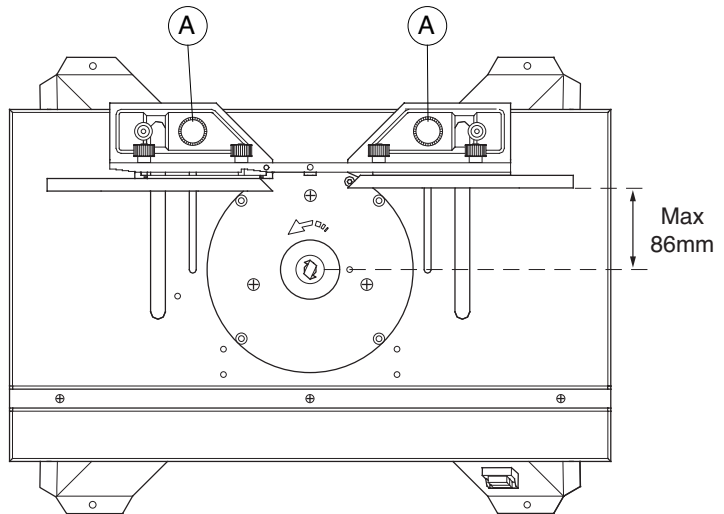

- 3 To adjust fence cheeks loosen four back knobs (B). Slide cheeks in and out to suit cutter. Leave gap of 3mm.
- 4 Lock cheeks by tightening four knobs (B).

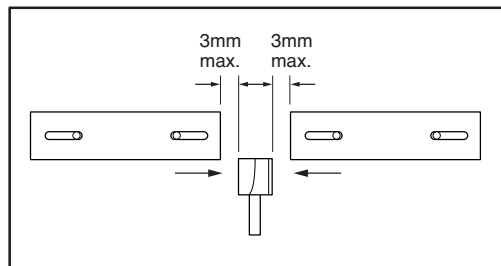
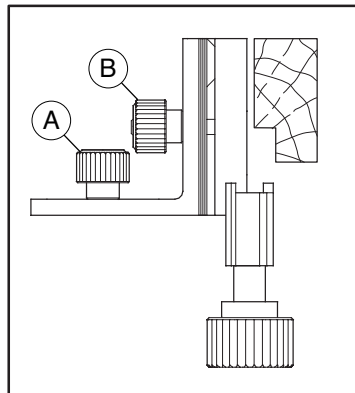

**Edge Moulding and Grooving**



- 1 Isolate from power source.
- 2 Fit cutter.
- 3 Set back fence position.
- 4 Set top and side pressures.
- 5 Fit guard.
- 6 Check all knobs are tight.
- 7 Plug into power supply.
- 8 Switch on.
- 9 Feed right to left.
- 10 Switch off.

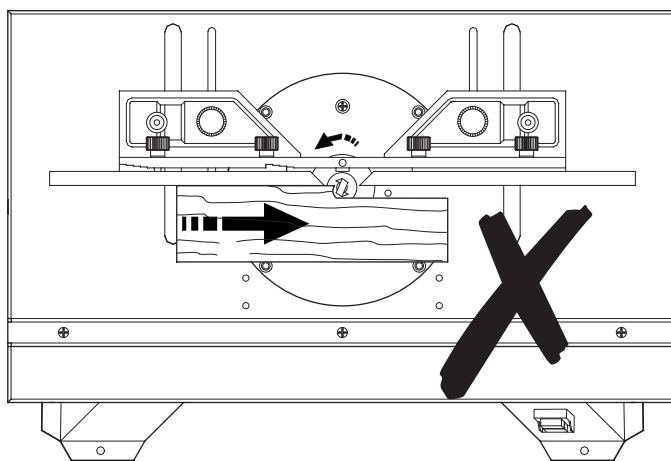
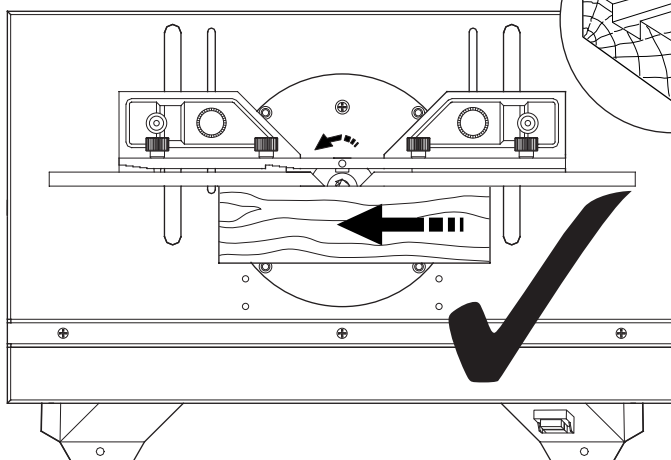
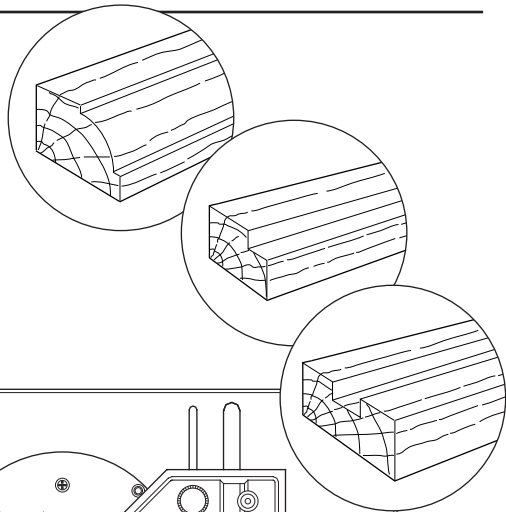



**Stopped Moulding** 

- 1 Isolate from power supply.
- 2 Fit cutter.
- 3 Set back fence position. Fit some stops to back fence using cramps.
- 4 Fit guard.
- 5 Check all knobs are tight
- 6 Plug into power supply.
- 7 Switch on.
- 8 Drop material against infeed stop A and pivot into cutter.
- 9 Feed right to left, until reaching outfeed limit stop B.
- 10 Pivot at outfeed stop.
- 11 Switch off.

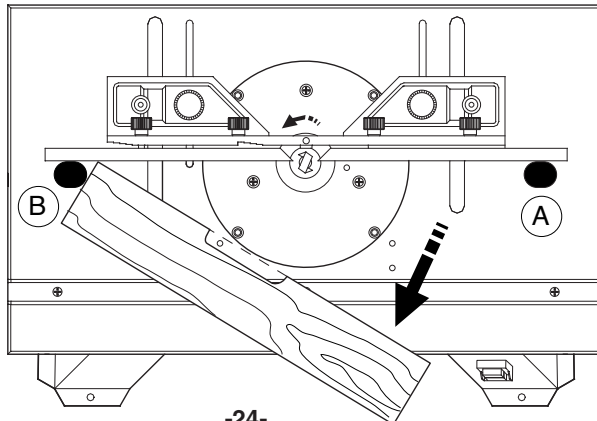
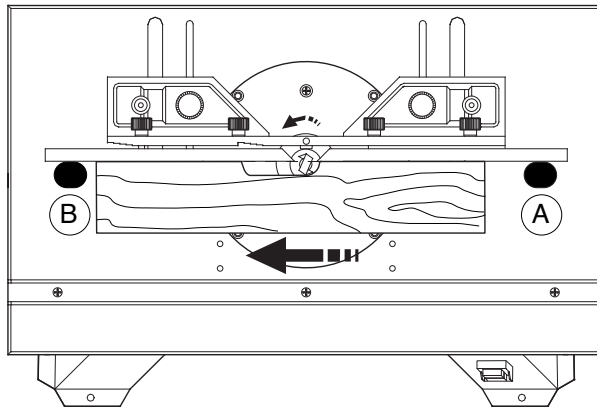
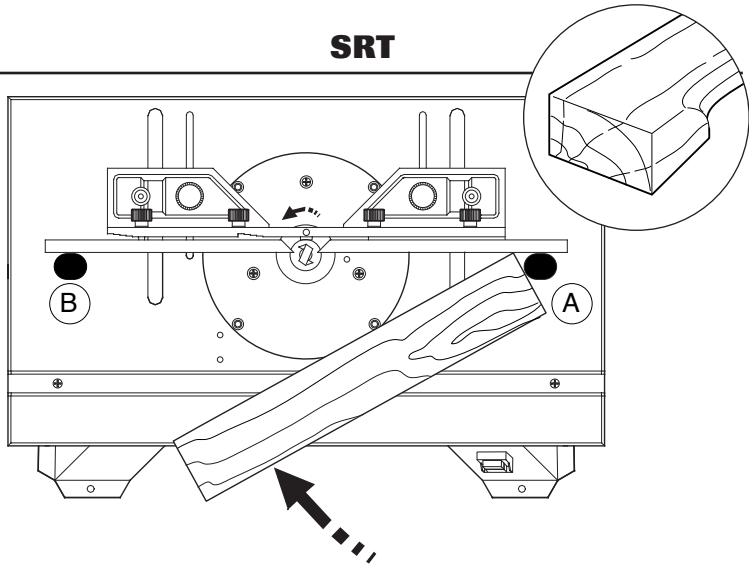

**Edge Planing** 

- 1 Isolate from power supply.
- 2 Fit cutter.
- 3 Loosen back knobs A and adjust stepper on outfeed cheek to required step in 0.8mm increments. Lock both knobs A.
- 4 Adjust back fence position so that cutter edge is flush with outfeed cheek. Lock back fence position.
- 5 Fit pressures and guards.
- 6 Plug into power supply.
- 7 Feed right to left.
- 8 Switch off.

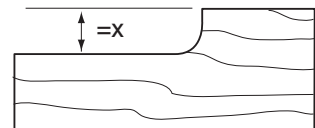
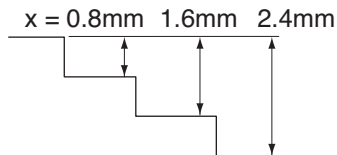
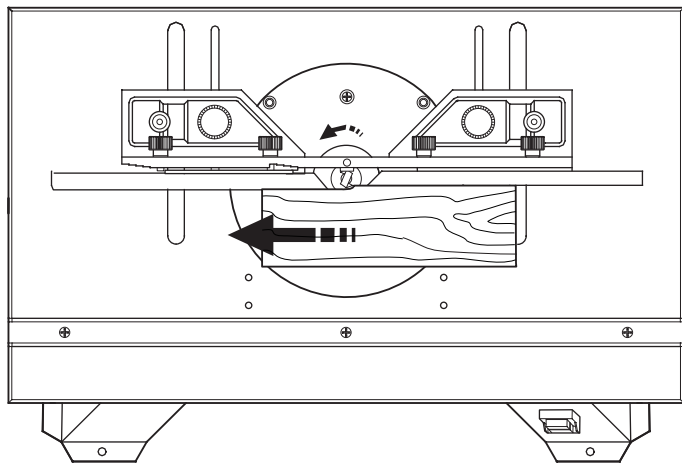
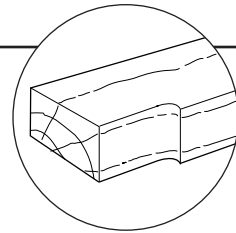
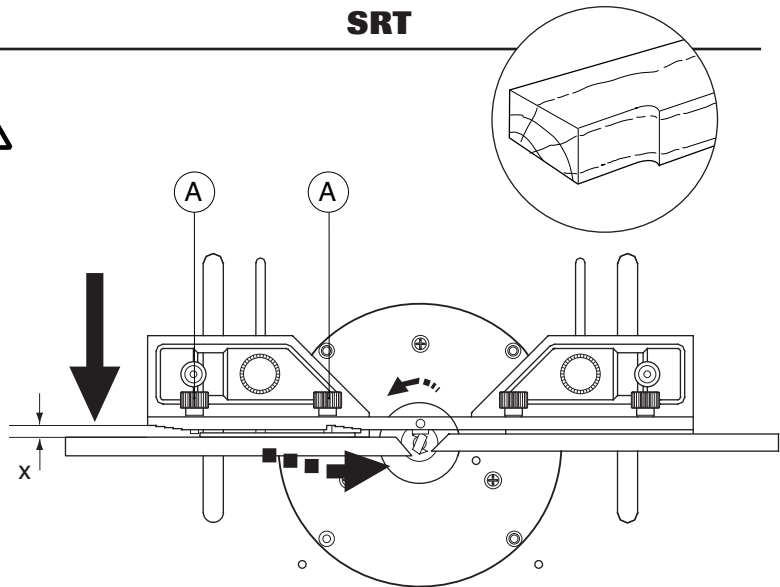

**Mitre Fence**

- ① Isolate from power supply.
- ② Fit cutter.
- ③ Adjust angle of mitre fence by loosening knob and turning protractor head to line up angle required with arrow.
- ④ Place component onto mitre fence.
- ⑤ Plug into power supply.
- ⑥ Feed right to left holding component securely.
- ⑦ Switch off.

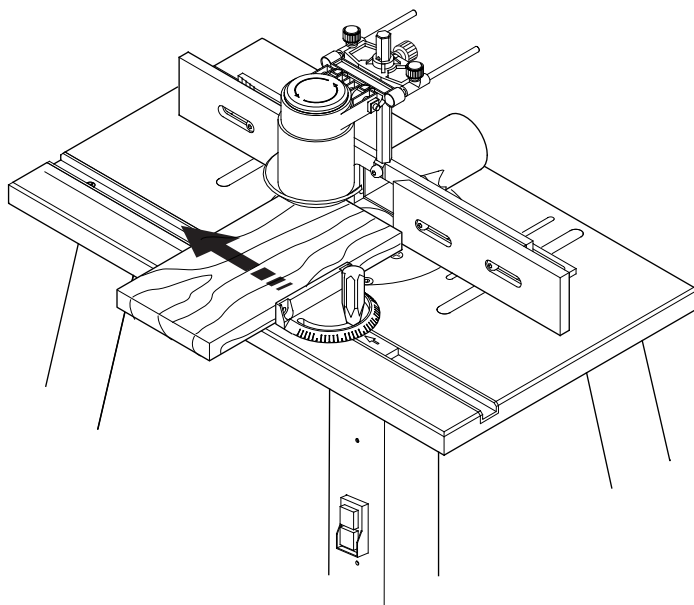

**Lead-on Pin**



- 1 Isolate from power supply.
- 2 Fit lead-on pin into threaded hole using 4mm hex key.
- 3 Move back fence back.
- 4 Fit cutter.
- 5 Fit top guard.
- 6 Plug into power supply.
- 7 Support component onto the lead-on pin and swing into cutter.
- 8 Mould component.
- 9 Switch off.

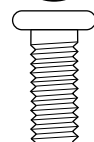
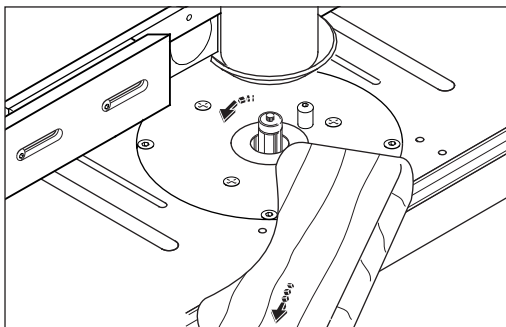
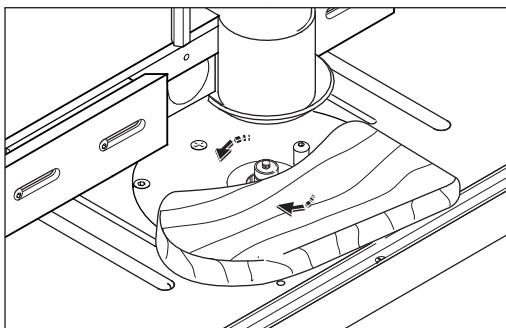
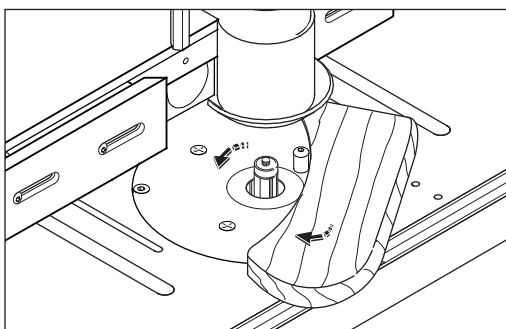
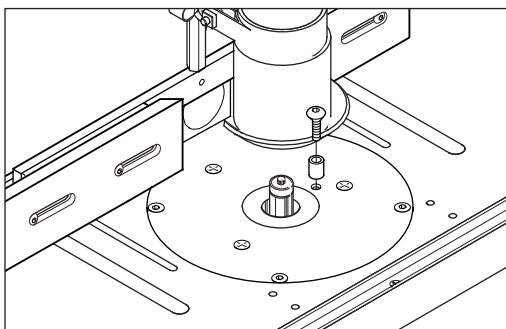

**x 1**

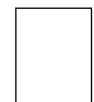

**x 1**

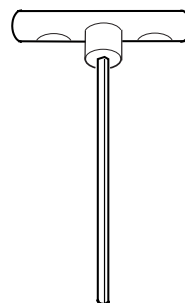

## **MAINTENANCE**

The router table has been designed to operate over a long period of time with a minimum of maintenance. Continual satisfactory operation depends upon proper tool care and regular cleaning.

### ■ **Cleaning**

Keep the grooves clear of sawdust.  
Regularly clean the table with a soft cloth.

### ■ **Lubrication**

Your router table requires no additional lubrication.

## **RECYCLING**

Router table, accessories and packaging should be sorted for environmentally friendly recycling.

## **GUARANTEE**

The router table carries a manufacturers guarantee in accordance with the conditions on the enclosed guarantee card.

For the location of your nearest Trend Service Agent, please call the telephone number at the back of this manual.

<b>SRT - SPARE PARTS LIST</b>			<b>v3.0 07/2003</b>
<b>No.</b>	<b>Qty.</b>	<b>Desc.</b>	<b>Ref.</b>
1	1	Table Top	WP-SRT/01
2	1	Insert Plate	SRT/PLATE/A
3	1	Scale Metric Right	WP-SRT/03
4	1	Scale Metric Left	WP-SRT/04
5	3	Leg 330mm x 76mm	WP-SRT/05
6	1	Leg 330mm x 76mm for Switch	WP-SRT/06
7	1	Back Fence	WP-SRT/07
8	1	Infeed Flat Riser	WP-SRT/08
9	1	Outfeed Step Riser	WP-SRT/09
10	1	No Volt Release Switch 230V UK Plug	WP-SRT/10
	0	No Volt Release Switch 230V EURO Plug	WP-SRT/10/EURO
	0	No Volt Release Switch 230V ANZ Plug	WP-SRT/10/ANZ
11	1	Mitre Fence Extrusion Track	WP-SRT/11
12	3	Screw Self Tapping Csk 3mm x 13mm PH	WP-SRT/12
13	1	Mitre Fence Bar	WP-SRT/13
14	1	Mitre Fence Protractor	WP-SRT/14
15	1	Mitre Fence Knob M6 x 17mm Male	WP-SRT/15
16	1	Dust Spout 57mm	WP-SRT/16
17	2	HDF Fence Cheek	WP-SRT/17
18	2	Finger Pressure 197mm x 82mm x 12.7mm	PRESSURE/1
19	1	Hex Post 160mm x 13mm	WP-SRT/19
20	1	Clear Guard	WP-SRT/20
21	1	Guard Ring	WP-SRT/21
22	2	Post Bracket	WP-SRT/22
23	1	Guard Ring Support	WP-SRT/23
24	1	Guard Top Cap	WP-SRT/24
25	4	Bolt Carriage M7 x 20mm x 125mm	WP-SRT/25
26	1	Insert Ring 40mm ID	WP-SRT/26
27	1	Insert Ring 30mm ID	WP-SRT/27
28	1	Insert Ring 20mm ID	WP-SRT/28
29	1	Lead-on Pin Body 10mm x 12.7mm	WP-SRT/29
30	16	Machine Screw Cap M6 x 12mm Socket	WP-SRT/30
31	2	Screw Self Tapping Pan 3mm x 7mm PH	WP-SRT/31
32	2	Knob 21mm Dia M6 x 8mm Male	WP-SRT/32
33	4	Knob 15mm Dia M5 x 5mm Male	WP-SRT/33
34	2	Knob 21mm Dia M6 x 25mm Male	WP-SRT/34

<b>SRT - SPARE PARTS LIST</b>			<b>v3.0 07/2003</b>
<b>No.</b>	<b>Qty.</b>	<b>Desc.</b>	<b>Ref.</b>
35	3	Washer M6	WP-SRT/35
36	1	Bolt Carriage M6 x 75mm	WP-SRT/36
37	4	Machine Screw Button M6 x 35mm Socket	WP-SRT/37
38	4	Machine Screw Csk M6 x 16mm Socket	WP-SRT/38
39	2	Knob 21mm Dia M6 x 40mm Male	WP-SRT/39
40	3	Nut Square M6	WP-SRT/40
41	4	Knob 21mm Dia M6 Female	WP-SRT/41
42	3	Machine Screw Csk M6 x 12mm Slot	WP-SCW/25
43	1	Machine Screw Button M6 x 14mm Lead-on Pin	WP-SRT/43
44	6	Washer Nylon M6	WP-SRT/44
45	3	Nut Hex M7 For Carriage Bolt	WP-SRT/45
46	1	Trend Logo Sticker	WP-SRT/46
47	1	Grub Screw M6 x 8mm	WP-SRT/47
48	20	Washer Split Ring 6mm	WP-SRT/48
49	0	Hose Adaptor 58mm to 39mm	CRT/3
50	1	Adaptor Body for CRT/3	WP-CRT/97
51	1	Adaptor Fitting for CRT/3	WP-CRT/98
52	1	Adaptor Clip for CRT/3	WP-CRT/99
53	0	Back Fence Complete	WP-SRT/53
54	0	Mitre Gauge Complete	WP-SRT/54
55	0	Top Profile Guard Complete	WP-SRT/55
56	4	Machine Screw Cap M6 x 8mm Socket	WP-SRT/56
57	1	T Handle Hex Key 4mm x 150mm	HK/T/04
58	1	Hex Key 3mm	WP-AP/03
59	1	Manual	MANU/SRT

**SRT - SPARE PARTS DIAGRAM**

**V3.0 07/2003**

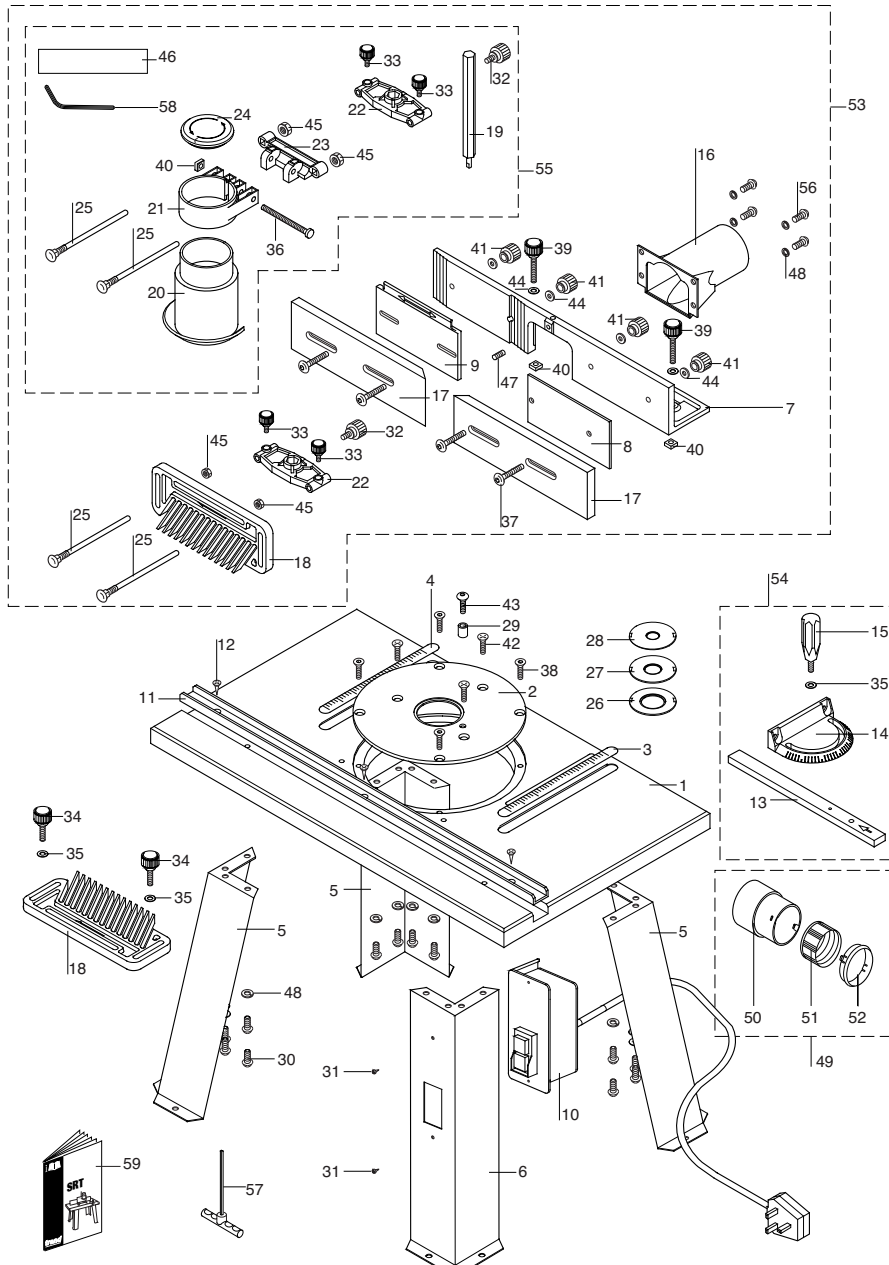



**NOTES**

MANU/SRT v3.0



**Trend Machinery & Cutting Tools Ltd.**

Odhams Trading Estate St Albans Road  
Watford WD24 7TR England

**Enquiries:** \_\_\_\_\_ 0800 487363

**Technical Support:** \_\_\_ 0044 (0) 1923 224681

**Fax:** \_\_\_\_\_ 0044 (0) 1923 236879

**Email:** \_\_\_\_\_ mailserver@trendm.co.uk

**Web:** \_\_\_\_\_ www.trendmachinery.co.uk

© Copyright Trend 2003. No part of this publication may be reproduced, stored or transmitted in any form without prior permission. Our policy of continuous improvement means that specifications may change without notice. Trend Machinery and Cutting Tools cannot be held liable for any material rendered unusable or any form of consequential loss. E&OE

® All trademarks acknowledged.