



**Router Table
Back Fence**

RT/FENCE



Please
read carefully
before use

ROUTER TABLE BACK FENCE REF. RT/FENCE

Thank you for purchasing this Trend router table back fence.

These instructions will show you how to assemble the back fence.

Parts Supplied in Kit

1. Back Fence Main Body with Cheeks (x1)
2. Hex Post (x1)
3. Clear Guard with Cap (x1)
4. Guard Ring (x1)
5. Post Bracket (x2)
6. Bolt Bracket Locking Knob (x4)
7. Post Bracket Knob (x2)
8. Finger Pressure (x1)
9. Bolt (x4)
10. Bolt Locking Nut (x4)
11. Hex Post Locking Screw (x1)
12. Dust Spout (x1)
13. Dust Spout Adapter (x1)
14. Dust Spout Adapter Body Fitting (x1)
15. Dust Spout Adapter Clip (x1)
16. Dust Spout Fixing Screw (x4)
17. Washer (x4)
18. Back Fence Locking Knob (x2)
19. Washer (x2)
20. Back Fence Locking Nut (x2)
21. Hex Key 3mm (x1)
22. Hex Key 4mm (x1)

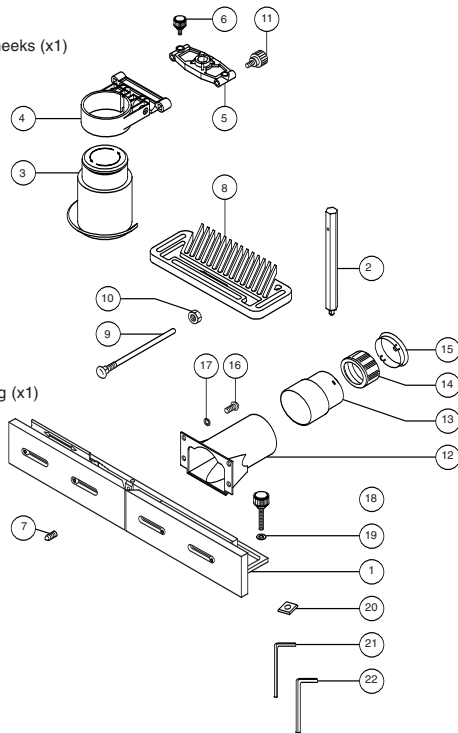

Safety Steps

1. Always wear eye protection such as goggles, ear protection and use effective respiratory protection.
2. Before making adjustments to the router, like changing the cutter, make sure the power is isolated correctly.
3. Before re-connecting to the mains supply, make sure the power switch on the router is in the 'off' position.
4. Do not switch on the router with the cutter in contact with the workpiece.
5. Before making adjustments always allow the cutter to stop rotating.
6. When routing keep your hands, hair and clothing clear of the cutter.
7. Make sure you follow the instructions which came with your router.
8. Ensure all visors, guards and dust extraction are fitted.
9. Trial cuts should be made in waste material before starting any project.
10. A No-Volt Release Switch should also be fitted to router tables.

All Trend tooling is guaranteed against any defects in either workmanship or material, except tools that have been damaged due to improper use or maintenance.

Our policy of continuous improvements mean that specifications may change without notice. Trend Machinery & Cutting Tools Ltd. cannot be held liable for any material rendered unusable, or for any form of consequential loss.

Fitting Dust Spout to Back Fence

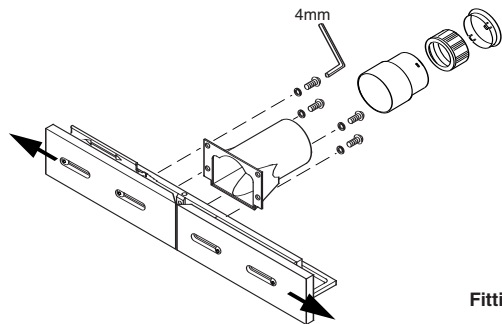

Fitting Top Guard

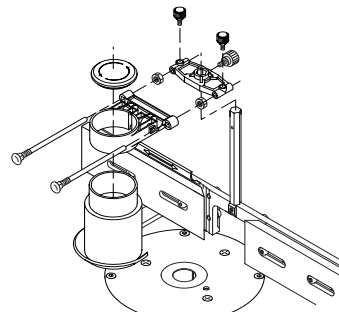

Height Positions When in Use

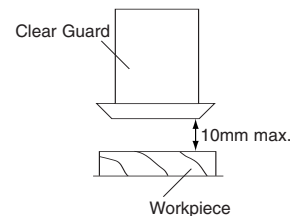
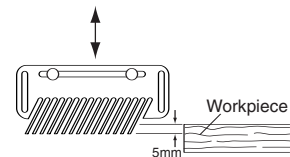

Fitting Top Pressure

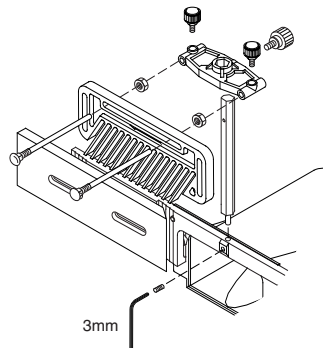

Fitting Back Fence to User Made Table

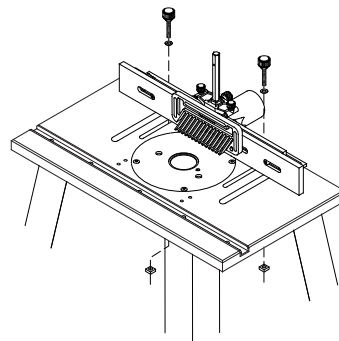

© Trend Machinery & Cutting Tools Ltd. 2004 E&OE

Trend Machinery & Cutting Tools Ltd.
 Odhams Trading Estate St Albans Road
 Watford WD24 7TR England
 Enquiries: 0800 487 363
 Technical Support: 01923 224681
 Fax: 01923 236879
 Email: mailserver@trendm.co.uk
 Web: www.trendmachinery.co.uk



RS 28982
 Stockholding
 & Supply



RECYCLABLE

