



8mm Router Carver System Mk2 RCCX8MMTC



INST/RCC8 v7.0

trend
routing technology

Please read carefully before use

8MM ROUTER CARVER SYSTEM MK2 REF. RCCX8MM

Thank you for purchasing this Trend product, which should give lasting performance if used in accordance with these instructions.

The following symbols are used throughout these instructions.



Denotes risk of personal injury, loss of life or damage to the tool in case of non-observance of the instructions.



Refer to the instruction manual of your power tool.

This cutter must not be put into service until it has been established that the power tool to be connected to this unit is in compliance with 98/37/EC (identified by the CE marking on the power tool).

INTENDED USE

The Router Carver system creates variable depth intricate wood carvings with a hand router. Woodcarvings can be made on doors, frames, drawer fronts or any flat wood-based material.

The system comprises a unique engraving cutter housed in a conical bearing guide, together with a set of templates and a template frame. The templates have accurately shaped slots with varying widths which guide the router carver both horizontally and vertically to give authentic carvings.



The 8mm Router Carver cannot be used with templates RCT/LP/C, RCT/SP/C, RCT/DR/C and RCT/KD/FD.

Various templates are offered for different applications. The primary designs, Classical and Royal continue through the entire range of applications providing a continuity of style for an entire house, room or individual furniture pieces.

The template frames are used to locate the templates when routing and are left clamped in place until all routing operations are finished. Slots from different template designs can be chosen and used in conjunction to create your individual design. To use the 8mm Router Carver a light duty professional hand router fitted with a 8mm collet is required. The router aperture must be at least 40mm in diameter and have a smooth plunging action. On some routers it may be necessary to slightly file part of the aluminium guide bush fixing tabs on the router base to prevent fouling.

THE CUTTER

The 8mm Router Carver Cutter MK2 consists of a 45° engraving V groove TCT cutter, housed in an aluminium cone shaped bearing guide. The shank is hollow for the cutter adjuster system. A set-up ring is provided to ensure the protrusion is exact and allows adjustment after re-sharpening.

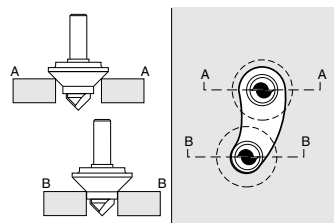
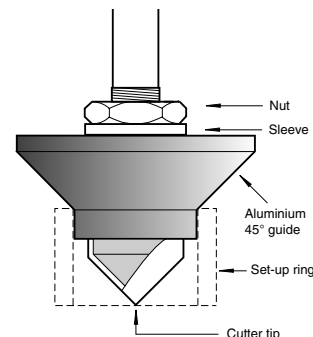

The carvings are routed by the horizontal movement of the router which is guided along the varying slots in the template. The plunge mechanism on the router is kept released allowing the router head to float up and down. The interaction of the slots with the cone, guides the router bit vertically up or down as the slots narrow and widen. Thus the depth and width of the cut is varied to give an authentic carving effect.

USING THE ROUTER CARVER

1. Ensure the cutter tip is flush with the top of the Set-up Ring. Adjust by loosening the locking nut and turning the cutter in or out as required. (In hard timber it may be necessary to set the cutter for a shallow 1st cut and then set to normal position for final cut). Adjustment may need to be made following re-sharpening.
2. Insert 3/4 of shank of the cutter into the collet and tighten. Release the plunge mechanism of the router allowing free travel along the plunge guides. To ensure a smooth plunging action, keep the guides lubricated with light oil or dry lubricant spray.
3. Select the required design templates and corresponding holding frame. Secure the frame to the workpiece by clamping or pinning. Ensure clamps do not interfere with path of router. Pins should be left slightly proud to facilitate easy removal.
4. Insert one of the templates into the frame, there may be up to three templates per design.

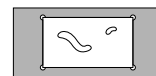
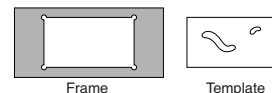

Before using cutter, please ensure it is correctly assembled and locking nut is fully tightened to correct torque setting



Recommended speed is 24,000rpm

© Trend Machinery & Cutting Tools Ltd. 2006 E&OE
© All trademarks acknowledged

Trend Machinery & Cutting Tools Ltd.
Odhams Trading Estate St. Albans Road
Watford WD24 7TR England
Enquiries: _____ 0800 487363
Technical Support: _0044 (0) 1923 224681
Fax: _____ 0044 (0) 1923 236879
Email: _____ enquiry@trendm.co.uk
Web: _____ www.trend-uk.com



RS 28982
Stockholding
& Supply



RECYCLABLE

5. Start up the router and position over the widest part of a slot (where possible). Plunge down until the cone shaped guide comes into contact with both edges of the slot, then move to the end of the slot.



By starting at the widest point the risk of the cutter coming into contact and damaging the template is reduced. If a template is inadvertently damaged, it can be repaired by filling and sanding to original shape.

6. Make one pass through the entire length of the slot, this removes the bulk of the material, follow up with a finishing pass. Repeat for all slots on the template. Maintain a slight downward pressure on the router as it moves along the slot. The depth and width of the cut will be automatically controlled by the interaction of the template with the cone shaped guide.

7. Once all cuts on the first side of the template have been completed, remove and realign the template as shown on the reverse of this leaflet.



The 8mm Router Carver is not a production tool. Trial cuts should be made on a waste piece of material first. Protective clothing including goggles should always be worn when routing.

HOW THE TEMPLATES WORK

Two Way Symmetrical Designs

After first cuts:

- Invert template
- Complete all cuts
- Repeat procedure for remaining templates in the design.

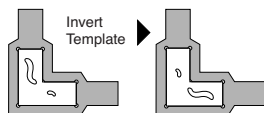
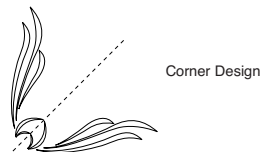
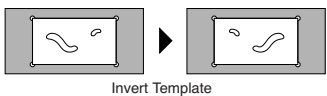
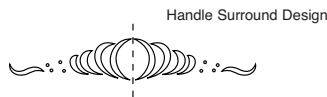

With these designs, each slot is used twice

Four Way Symmetrical Design

After first cuts:

- Rotate template 180°
- Complete all cuts
- Remove and invert template
- Complete all cuts
- Remove and rotate template 180°
- Complete all cuts
- Repeat entire procedure for remaining templates in the design.

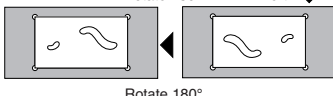
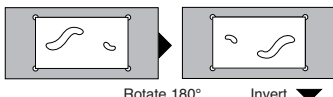
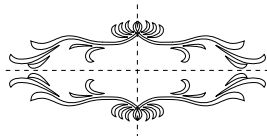

With these designs, each slot is used 4 times

Six Way Symmetrical Design

After first cuts:

- Rotate template to the next corner, 60°
- Complete all cuts
- Repeat for all corners on this surface of the template.
- Complete all cuts
- Invert the template and repeat the entire procedure.

Rosette designs can be used separately or added to some of the other designs.

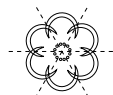

Rosettes can be held in a rosette frame, Ref. RCF/RS. Alternately, large rosette templates can be used in conjunction with panel door and kitchen door frames. Small rosette templates can be used in conjunction with the door rail frame.

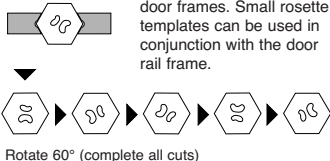

With these designs, each slot is used 6 times on each side i.e. each slot is used for 12 cuts.



All templates and frames are manufactured within acceptable tolerances. However, due to the nature of the material, it is possible that there may be some movement of the template within the holding frame. It is therefore advisable to select a corner of the frame as a datum and ensure the template is seated in that corner with each realignment of the template.

It is possible to vary some designs by excluding certain cuts. It will be necessary to perform a trial run to accurately identify the slot(s) which are not required. Slots from different template designs can be chosen and used in conjunction to create an individual design. Slots in the template that appear on the centre line of the design should only be cut once.

Spare Parts	Order Ref.
Cutter Tip with Threaded Shank	WP-RCC/1B
Aluminium Cone	WP-RCC/2B
Bearing	WP-RCC/4B
Circlips	WP-RCC/5B
Nut	WP-RCC/6B
Set-up Ring	WP-RCC/7
8mm Bore Sleeve	WP-RCC/10

Safety Points

- Disconnect power tool and attachment from power supply when not in use, before servicing, when making adjustments and when changing accessories such as cutters. Ensure switch is in "off" position and cutter has stopped rotating.
- Read and understand instructions supplied with power tool, attachment and cutter.
- Current Personal Protective Equipment (PPE) for eye, ear and respiratory protection must be worn. Keep hands, hair and clothes clear of the cutter.
- Before each use check cutter is sharp and free from damage. Do not use if cutter is dull, broken or cracked or if any damage is noticeable or suspected.
- The maximum speed (n_{max}) marked on tool or in instructions or on packaging shall not be exceeded. Where stated, the speed range should be adhered to.
- Insert the shank into the router collet at least all the way to the marked line indicated on the shank. This ensures at least 3/4 of shank length is held in collet. Ensure clamping surfaces are clean.
- Check all fixing and fastening nuts, bolts and screws on power tool, attachment and cutting tools are correctly assembled, tight and to correct torque setting before use.
- Ensure all visors, guards and dust extraction is fitted.
- The direction of routing must always be opposite to the cutter's direction of rotation.
- Do not switch power tool on with the cutter touching the workpiece.
- Trial cuts should be made in waste material before starting any project.
- Repair of tools is only allowed according to tool manufacturers instructions.

Please see www.trend-uk.com/safety for more safety advice.

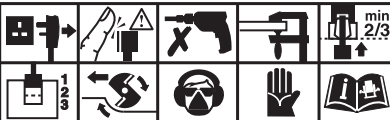

Our policy of continuous improvements mean that specifications may change without notice. Trend Machinery & Cutting Tools Ltd. cannot be held liable for any material rendered unusable, or for any form of consequential loss.