

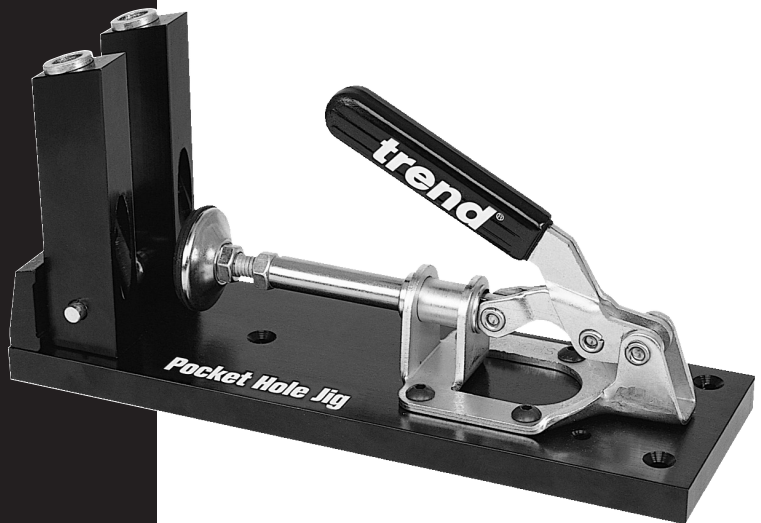

# PH/JIG



**trend**<sup>®</sup>  
routing technology



Please read these instructions before use.



Dear Customer

Thank you for purchasing this Trend product, we hope you enjoy many years of creative and productive use.

Please remember to return your guarantee card within 28 days of purchase.

## CONTENTS

<b>TECHNICAL DATA</b>	1
<b>SAFETY PRECAUTIONS</b>	2
<b>ITEMS ENCLOSED</b>	3
<b>POCKET HOLE CONCEPT</b>	3
<b>DESCRIPTION OF PARTS</b>	4
<b>ASSEMBLY &amp; ADJUSTMENT</b>	
– Setting up the Jig	5
– Setting Pocket Hole Centres	5
– Setting the Push-Pull Clamp	5
– Setting the Drill Bit Depth	6
<b>OPERATION</b>	
– Material Thickness	7
– Pocket Hole Spacing	7
– Drilling the Pocket Holes	8
– Assembling the Joint	9
<b>APPLICATIONS</b>	10-12
<b>ACCESSORIES</b>	13
<b>MAINTENANCE</b>	13
<b>ENVIRONMENTAL PROTECTION</b>	13
<b>GUARANTEE</b>	13
<b>SPARE PARTS</b>	
– Spare Parts List	14
– Spare Parts Diagram	15
<b>TROUBLE SHOOTING</b>	16

## TECHNICAL DATA

Material thickness:	Min.	16mm
	Max.	38mm
Material width:	Min.	38mm
Drill bit size		9.5mm
Hole pitch		29-63mm

The following symbols are used throughout this manual:



Denotes risk of personal injury, loss of life or damage to the tool in case of non-observance of the instructions in this manual.



Denotes risk of electric shock.



Refer to the instruction manual of your power tool.

This unit must not be put into service until it has been established that the power tool to be connected to this unit is in compliance with 2006/42/EC (identified by the CE marking on the power tool).

## INTENDED USE

This accessory is to be used with a drill with minimum 10mm chuck capacity to allow pocket hole jointing of softwoods and hardwoods. It is ideally suited for use with materials 19mm thick.



If you require further safety advice, technical information or spare parts, please call Trend Technical Support or visit [www.trend-uk.com](http://www.trend-uk.com)

### SAFETY



#### WARNING:

Observe the safety regulations in the instruction manual of the power tool to be used. Please read the following instructions carefully. Failure to do so could lead to serious injury. When using electric tools, basic safety precautions, including the following should always be followed to reduce the risk of fire, electric shock and personal injury. Also observe any applicable additional safety rules. Read the following safety instructions before attempting to operate this product.

#### PLEASE KEEP THESE INSTRUCTIONS IN A SAFE PLACE.

The attention of UK users is drawn to The Provision and Use of Work Equipment Regulations 1998, and any subsequent amendments.

Users should also read the HSE/HSC Safe Use of Woodworking Machinery Approved Code of Practice and Guidance Document and any amendments.

Users must be competent before using our products.

#### IMPORTANT NOTE:

**Residual Risk.** Although the safety instructions and operating manuals for our tools contain extensive instructions on safe working with power tools, every power tool involves a certain residual risk which cannot be completely excluded by safety mechanisms. Power tools must therefore always be operated with caution!

#### General

1. Disconnect power tool when making any adjustments. When not in use, before servicing and when changing accessories such as cutters, disconnect power tool and attachment from power supply. Ensure the machine is switched off before plugging tool in or connecting to a power supply.
2. Always mount the power tool, accessory or attachment in conformity with the present instructions. The tool should not be modified or used for any application other than that for which it was designed.
3. Keep children and visitors away. Do not let children or visitors touch the tool, accessory or attachment. Keep children and visitors away from work area. Make the workshop child proof with padlock and master switch.
4. Dress properly. Do not wear loose clothing or jewellery, they can be caught in moving parts. Rubber gloves and non-skid footwear is recommended when working outdoors. Wear protective hair covering to contain long hair.

5. Consider working environment. Do not use the product in the rain or in a damp environment. Keep work area well lit. Do not use power tools near gasoline or flammable liquids. Keep workshop at a comfortable temperature so your hands are not cold. Connect machines that are used in the open via a residual current device (RCD) with an actuation current of 30 mA maximum. Use only extension cables that are approved for outdoor use.
6. The accessory or attachment must be kept level and stable at all times.
7. Keep work area clean. Cluttered workshops and benches can cause injuries. Ensure there is sufficient room to work safely.
8. Secure idle tools. When not in use, tools should be stored in a dry and high or locked up place, out of reach of children.
9. For best control and safety use both hands on the power tool and attachment. Keep both hands away from cutting area. Always wait for the spindle and cutter to stop rotating before making any adjustments.
10. Always keep guards in place and in good working order.
11. Remove any nails, staples and other metal parts from the workpiece.
12. Maintain tools and cutters with care. Keep cutters sharp and clean for better and safer performance. Do not use damaged cutters. Follow instructions for lubricating and changing accessories. Keep handles dry, clean and free from oil and grease.
13. Maintain accessories. Do not use damaged accessories. Only use accessories recommended by the manufacturer.
14. Check damaged parts. Before operation inspect the attachment, the power tool, the cable, extension cable and the plug carefully for signs of damage. Check for alignment of moving parts, binding, breakage, mounting and any other conditions that may effect its operation. Have any damage repaired by an Authorised Service Agent before using the tool or accessory. Protect tools from impact and shock.
15. Do not use tool if switch does not turn it on or off. Have defective switches replaced by an Authorised Service Agent.
16. Don't over reach. Keep proper footing and balance at all times. Do not use awkward or uncomfortable hand positions.
17. Don't abuse the cable. Never carry power tool or accessory by cord or pull it to disconnect from the socket. Keep cord from heat, oil and sharp edges. Always trail the power cord away from the work area.
18. Connect dust extraction equipment. If devices are provided for the connection of dust extraction and collection facilities, ensure these are connected and properly used.
19. Check all fixing and fastening nuts, bolts and screws on power tool, attachment and cutting tools before use to ensure they are tight and secure. Periodically check when machining over long periods.
20. Stay alert. Watch what you are doing. Use common sense. Do not operate tools when you are tired, under the influence of drugs or alcohol.
21. Personal Protective Equipment (PPE). All PPE must meet current UK and EU legislation.
22. Do not leave tools running unattended. Do not leave tool until it comes to a complete stop.
23. Always clamp workpiece being machined securely.
24. Only use cutting tools for woodworking that meet EN847-1/2 safety standards, and any subsequent amendments.
25. Vibration levels. Hand held power tools produce different vibration levels. You should always refer to the specifications and relevant Health & Safety Guide.
26. Use the attachment with the power tools and accessories specified in this manual only. Do not force the tool or attachment to do a job for which it is not designed.

Version 6.1 01/2014 PT1

## **POCKET HOLE CONCEPT**

A pocket hole concept involves placing one piece of the material to be joined in the jig and boring two counter-bored holes with a special stepped drill. This piece of material is joined to the other piece and assembled with 30mm long self-tapping screws, which once driven into the material will provide a strong joint. No pilot hole is required, but wood glue should be used to provide a strong long lasting joint. The screw removes the need for clamping and the component can be handled whilst the glue is drying.

It is ideally suited for use with 19mm (3/4") thick material because the distance from the base of the jig to the drill guide, combined with the angle of the screws, causes the screw to exit the 19mm material at its centre.

An accessory stepped drill bit with collar Ref. PH/DRILL/95Q is available with a 1/4" hex quick-change fitting, which allows faster tool change.

## **ITEMS ENCLOSED**

- 1 x Pocket Hole Jig
- 1 x Stepped drill 9.5mm (3/8") diameter x 150mm long HSS
- 1 x Depth collar for stepped drill
- 1 x Square drive screwdriver bit No. 2 x 75mm long
- 1 x Square drive screwdriver bit No. 2 x 150mm long
- 100 x Self-tapping square head screws No.7 x 30mm
- 1 x Hex key 4mm A/F
- 1 x Hex Key 3mm A/F
- 1 x Hex Key 2.5mm A/F
- 1 x Face clamp 152mm long x 42mm throat x 42mm opening
- 3 x Particle board screw No. 8 x 25mm Pozi
- 1 x Manual
- 1 x Guarantee registration card

## **ITEMS REQUIRED**

- Drill with minimum 10mm chuck.
- Hand tools.

**DESCRIPTION OF PARTS**

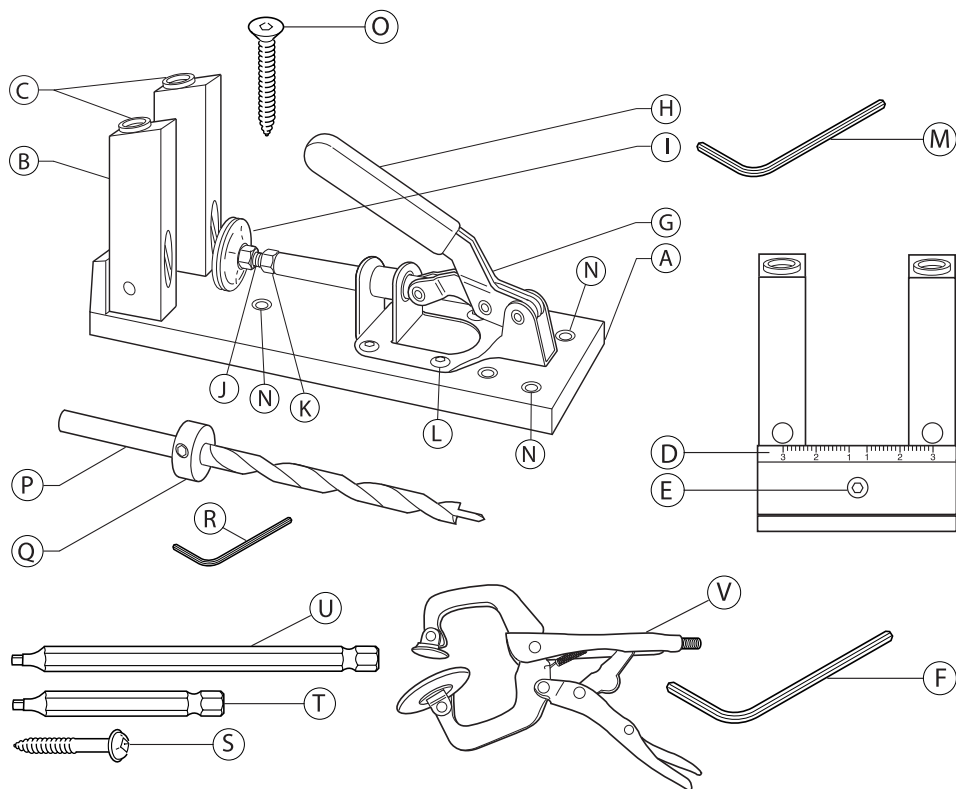

- |   |  |
|---|--|
| (A) Pocket hole jig body                          | (M) Push-pull securing screw hex key 3mm A/F                                     |
| (B) Guide columns with solid hardened bushes      | (N) Bench fixing holes   |
| (C) Solid bush drill guide hole                   | (O) Bench fixing screws No. 8 x 25mm   |
| (D) Guide column equidistant scale                | (P) Stepped drill  |
| (E) Guide column adjustment screw                 | (Q) Stepped drill depth collar   |
| (F) Guide column adjustment screw hex key 4mm A/F | (R) Depth collar hex key 2.5mm A/F   |
| (G) Push-pull toggle clamp                        | (S) Square drive self-tapping screw No. 7 x 30mm                                 |
| (H) Push-pull toggle clamp handle                 | (T) Short square drive screwdriver bit No. 2 x 75mm for self-tapping screws      |
| (I) Clamping pad                                  | (U) Long square drive screwdriver bit No. 2 x 150mm long for self-tapping screws |
| (J) Adjustable clamping pad stud                  | (V) Face clamp   |
| (K) Adjustable clamping pad lock nut              |  |
| (L) Push-pull securing machine screws             |  |

## ASSEMBLY & ADJUSTMENT

### Setting Up The Jig



The Pocket Hole Jig can be used both fixed to a bench or portably depending on the application. The most common position is screwed to a bench and with the material clamped into the jig.

In the fixed bench position it is advisable to secure material the same thickness as the jig, either side of the jig body. This makes it easier to slide large components into the jig and also prevents it tipping.

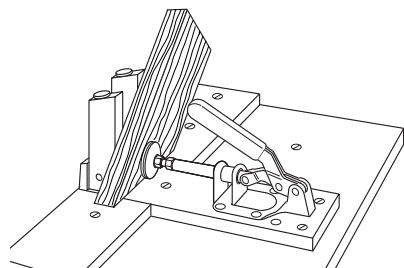

The built-in push-pull clamp arrangement allows both hands to be free for drilling in both applications.

For use portably, the jig can be clamped to the actual component. This is necessary for large or heavy components.

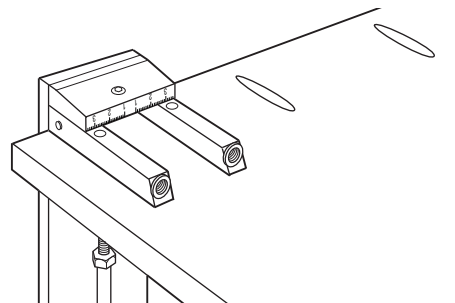

**Always remove plug from power source before making any adjustments.**

### Setting Pocket Hole Centres

The pocket hole jig has variable distance drill guides to allow material of minimum width of 38mm (1-1/2") to be joined.

- The adjustable guides can be locked at various positions allowing hole centres of 29mm (1-1/8") to 63mm (2-1/2") per set up.
- Once the hole positions have been decided, both the drill guide columns can be set equally using the scale and locked in position using the 4mm A/F hex key.

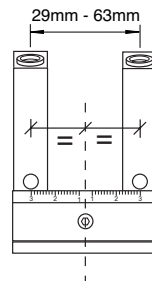

### Setting the Push-Pull Clamp

To bore the pocket holes you will need to set the clamp position to ensure it holds the material securely. The Pocket Hole Jig has two positions for fitting the clamp. The first position (A) allows material thickness of 16mm to 18mm to be clamped. The second position (B) allows material from 18mm to 38mm thick to be clamped.

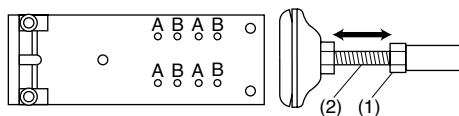

- Using the 3mm hex key loosen the four machine screws and remove them.
- Move clamp back one set of holes and replace screws and tighten securely.
- Loosen the locking nut (1) on the clamp pad stud (2) using a 12mm A/F spanner.
- Screw clamp pad in and out to find the correct setting. The correct setting is achieved when the clamp handle snaps closed when using two fingers of pressure.
- When set tighten clamp locking nut (1).

If the component moves when drilling the pocket apply more pressure with the clamp by screwing out the pad further.

## Setting the Drill Bit Depth

The depth collar on the drill is used to control the depth of the pocket, which also sets the length of the screw that protrudes through and into the joining piece.

- To set the depth collar on the stepped drill, firstly remove the component from the jig, loosen the collar set screw using the 2.5mm A/F hex key and place onto the shank of the drill about 50mm down.
- Lightly tighten the set screw to lock the collar onto the drill.
- Put the stepped drill with collar fitted into the bushed hole in the column, until the collar touches the top of the bush.
- Gently loosen the set screw on the collar and adjust the depth of the drill so that the end of the drill tip is about 3mm above the jig base (a packing piece or coin can be used).
- Tighten the set screw securely. The collar is now set for 30mm long screws, which gives approximately half of the screw into each workpiece.
- Check collar position is correct before beginning to drill.

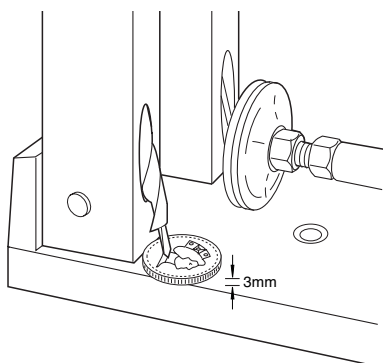

By adjusting the collar back or forward will give a deeper or shallower pocket. If the depth collar

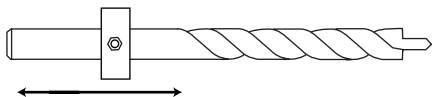

position is set too deep the screw may protrude through the face of the joining piece. If too shallow the screw may not enter into the joint sufficiently.

When working with thin material (16mm) and mitres, the counter-bored hole will need to be shallower than standard. Shallower counter-bored holes will result in the head of the screw being closer to or even above the surface, this is acceptable in certain applications where the head of the screw is invisible from view.

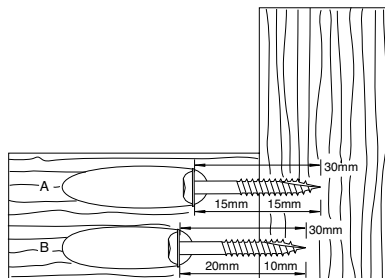
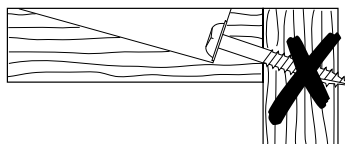
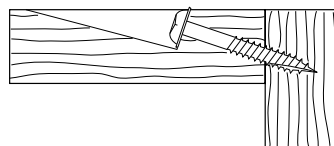

**Before using the pocket hole jig for the first time, it is recommended that a number of trial cuts are made in waste timber as this will allow the drill to bed into the drill guide bushes in the columns. During the bedding in process there will be evidence of some metal swarf.**



**OPERATION**



**Material Thickness**

The jig can be used on material from 16mm to 38mm thick. If the material is thinner than optimum 19mm thickness the screw will not exit in the centre and likewise if thicker material is used. Even though the screw does not exit in the centre a tight joint will be still be created. As the material gets thicker however it may be advisable to put pocket holes on multiple sides of the component.

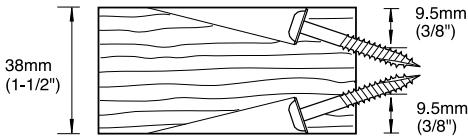
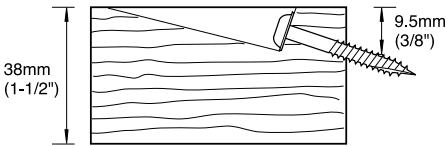
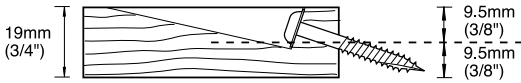

**Pocket Hole Spacing**

When boring framing material, two pocket holes should be used to keep the timber from twisting. When working with long pieces of timber to create a board (jointing edge to edge) to make a table top for example, single pockets can be drilled at between 150mm to 200mm centres.

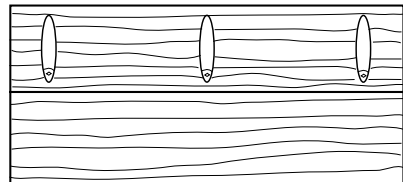
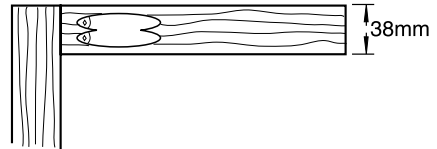
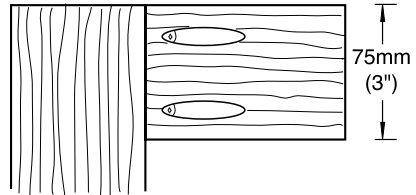
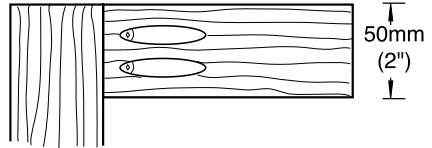

### **Drilling the Pocket Holes**



Boring the counter-bored hole involves drilling with a stepped drill into one of the joint pieces.



**Ensure jig is clamped/screwed securely to the work bench and placed at a suitable and comfortable work height.**



**Ensure component is held securely before drilling.**



**Ensure working position is comfortable. Keep proper footing at all times. Consider working environment before using tools.**

- Fit the material to be pocket hole drilled into the jig and clamp tightly.
- Fit the drill bit with depth collar already set into the chuck of the drill used.
- Place drill bit into top section of the bush hole in drill guide. Do not place the drill tip against the component.
- Switch on drill at full speed (clockwise direction) and drill into the component until the collar touches the bush. Gently pulling drill in and out whilst drilling will allow wood chips to clear more easily.
- Once depth is reached switch drill off and withdraw drill bit from drill guide.
- Repeat for other pocket hole and then remove component.
- Repeat operation for the remaining pieces.



**Do not push hard on the drill until the drill pilot tip of the drill bit is fully into the work piece and the counterbore section is actually cutting.**



**Use a high drilling speed to increase drill life (2000rpm or higher).**



**Keep the drill bit sharp.**



**Make sure drill bit is held in chuck securely. If the drill spins loose in the chuck the shock can break the drill bit tip.**



**Place the drill bit into the top section of the drill guide hole before spinning. Do not place the drill tip against the component until the drill is at full speed.**

## Assembling the Joint

Self-tapping pocket hole screws do not need to have pilot holes drilled, even in hardwoods. Other types of screws can work in the jig but the self-tapping screws reduce splitting in the timber and are hardened to reduce breakage. Whenever possible use glue on the joint unless it is necessary to disassemble the joint.

To aid assembly on corner joints, it is advisable to use a high batten, clamped to the bench. The components can be pushed against it to keep the two parts flush to each other, whilst screwing them together.

When assembling edge to edge joints it is advisable to use the face clamp to keep both parts flush. The face clamp can be adjusted to suit material thickness by adjusting the locking nut on the handle of the face clamp. The larger pad on the face should be on the face side of the material.

The screw should be driven into the component using a torque control screwdriving drill. The torque control allows control of the tightness of the screws into the wood and minimise the possibility of stripping the screw. The longer square drive screwdriver bit is used for most pocket hole screw driving applications. The shorter bit allows for use in tight spaces. The screwdriver bits have 1/4" quick change shanks and can be used directly into a drill chuck or more conveniently into a Trend Snappy quick change drill chuck Ref. SNAP/QC.

If a torque control screwdriver is not available start to screw with a conventional drill and then finish off by hand using a square drive hand screwdriver or the Trend Snappy Hand driver Ref. SNAP/HAND/1.

If access to the screws are tight the screwdriver bits can be fitted into a 1/4" socket fitted to a ratchet or use a flexible shaft screwdriver.

After use, store jig carefully.

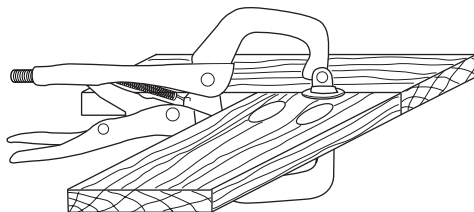
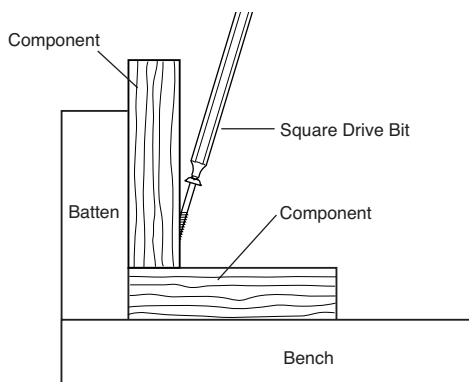

## APPLICATIONS

**Frame Corner Joints** – faster and stronger than dowel and biscuits. Self clamping whilst glue is drying.

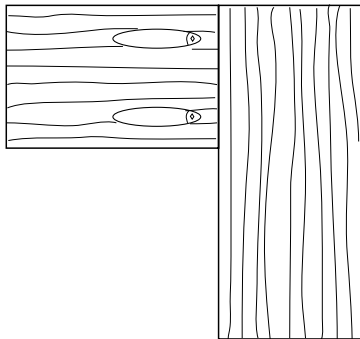

**Square Corner Joints** – faster and stronger than dowel and biscuits. Self clamping whilst glue is drying.

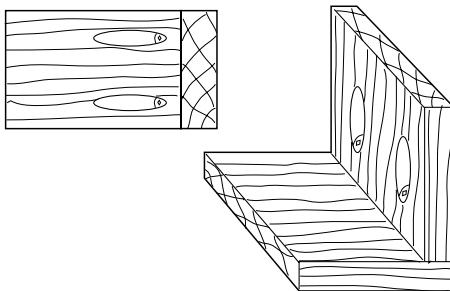

**Mitred Frame Corner Joints** – for narrow frames a single pocket hole is necessary. Cut the mitre and rout any rebates before boring the pocket holes. For material less than 50mm wide it may be necessary to tilt the pocket hole piece so that the hole is not perpendicular to the mitred edge.

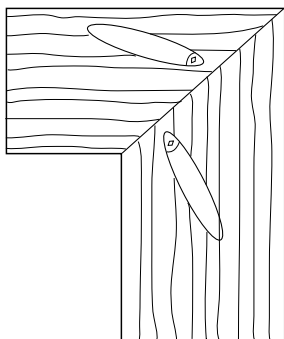

**T- Joints** – faster and stronger than dowel and biscuits. Self clamping whilst glue is drying.

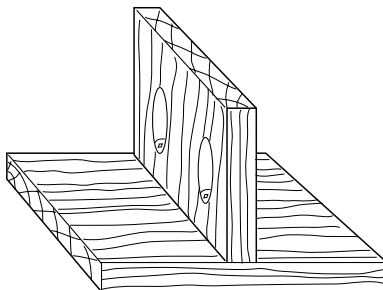

**When changing material or joint application, test the depth of the drill and collar before drilling into the workpiece. Test drill in waste pieces of the same thickness. Then drill a screw into the pocket joint only and lay it against the jointing piece to see if screw depth is correct.**

**Angled Joints** – eliminates difficult clamping up. The joint is created not by cutting each mitre to half the angle but by cutting angle on one joining piece and drilling pocket holes into the square piece. The method results in the mitred edge having an overhang, which will need to be removed by plane or sander.

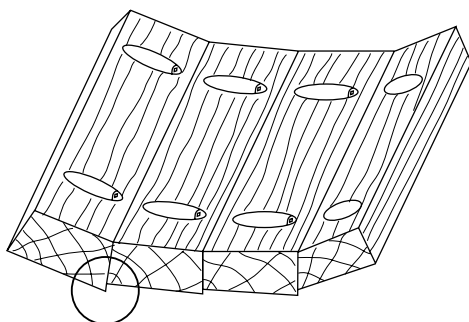
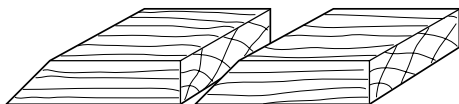

**Curved Joints** – this uses the same technique as the angled joint, but the angles will be shallower (5° to 15°). The overhang will need to be removed as previous.

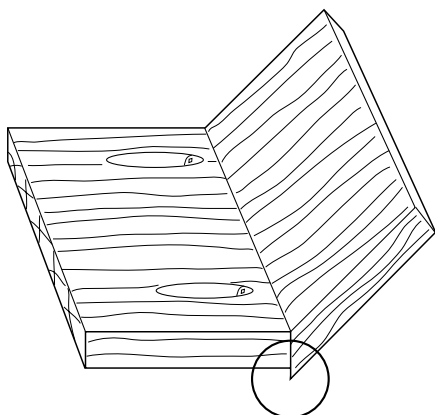

**Mitred Corner Joints** – joining two pieces with 45° mitres with the pocket jig is not advisable, however a 90° change of direction can be created by using a bevel-jointing piece. The joint comprises of a 90° infill piece with 45° mitres on both sides.

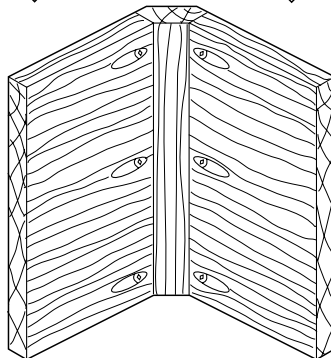
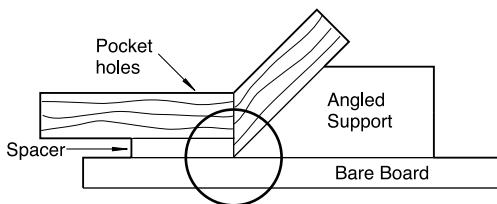
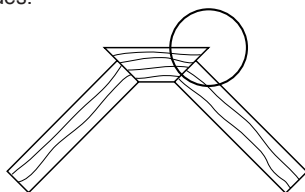

**Plinths** – faster and stronger than dowel and biscuits.

**Edge to Edge Joints** – allows narrow strips to be jointed to create wider boards such as a table top.

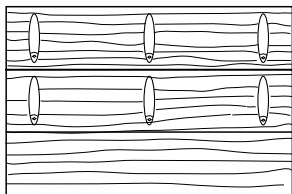

**Edging of countertops or shelving** – quick and easy way to join edging onto plywood, MDF or Particle board shelves.

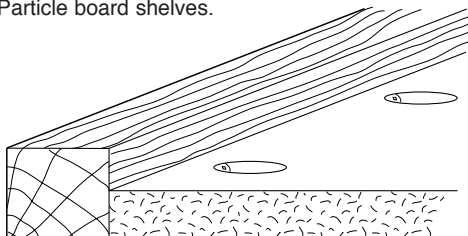

**Post and Rail Joints** – pocket holes allow strong table and chair joints. For fitting table tops to rails, the rails will need to be pocket hole drilled. To allow for the movement of the timber as it expands and contracts the hole must be slightly over size. This is achieved by lifting the rail about 3mm off the base of the jig. This should allow the pilot tip of the drill to break through the end of the timber, giving the screw space for some movement. Alternatively move the rail sideways slightly to drill another pocket hole (interlocking) allowing a slot for the screw.

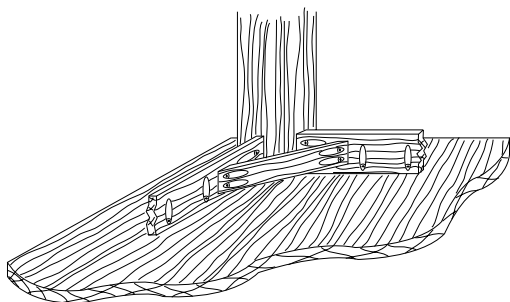

**Jig making** – very useful for jig making and temporary assembly operations. Ideal for routing jigs.

**Framed Panel (Cabinet) Joints** – pocket holes can be used for almost all framed cabinet carcass construction.

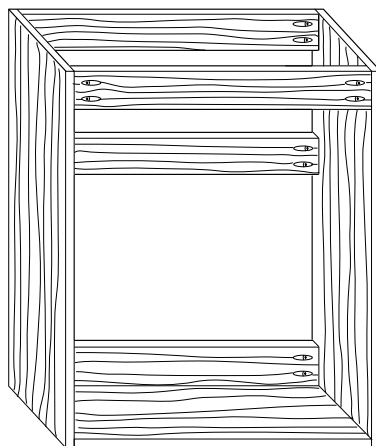
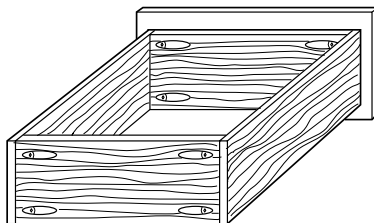

## ACCESSORIES

Please use only Trend original accessories.

### Self Tapping Screws Square drive

Standard Thread No.7x30mm.

No.7 x 30mm.

Pack 500

Ref. PH/7X30/500

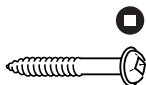

### Self Tapping Coarse Thread Screws Square Drive

Coarse Thread No.7 x 30mm.

For softer woods, plywood and particle board

Pack 500

Ref. PH/7X30/500C

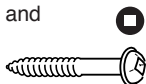

### Quick Release Shank Drill Bit

Ref. PH/DRILL/95Q

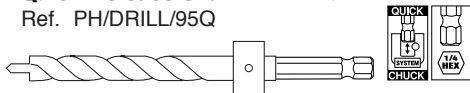

### Pocket Hole Plug Cutter

A tool steel pellet cutter that is used in a pillar drill to allow plugs to be made to cover the pocket hole.

Allows plugs up to 52mm long to be created in end grain.

Ref. PH/PC/95

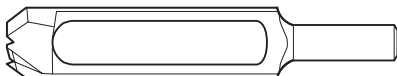

## MAINTENANCE

Please use only Trend original spare parts and accessories.

The accessory has been designed to operate over a long period of time with minimum of maintenance. Continual satisfactory operation depends upon proper tool care and regular cleaning.

### Cleaning

- Keep the threads and clamp mechanism clear of sawdust and resin build-up.
- Regularly clean with a soft cloth.

### Lubrication

- Periodically lubricate the holes in the guide columns with PTFE dry lubricant.

### Storage

- After use store jig in its packaging or in a cupboard.

### Drill Bit Care

- Ensure the drill bit is sharp.
- Check tightness of depth collar set screw.

## ENVIRONMENTAL PROTECTION



**Recycle raw materials instead of disposing as waste.**

Packaging should be sorted for environmental-friendly recycling.

The product and its accessories at the end of its life should be sorted for environmental-friendly recycling.

## GUARANTEE

All Trend products are guaranteed against any defects in either workmanship or material, except products that have been damaged due to improper user or maintenance.

Please use only Trend original spare parts.

<b>PH/JIG - SPARE PARTS LIST</b>			<b>v3.0 7/2014</b>
<b>No.</b>	<b>Qty.</b>	<b>Desc.</b>	<b>Ref.</b>
1	1	Jig Body	WP-PHJ/01
2	2	Guide Column with Solid Bush	WP-PHJ/02
3	1	Guide Column Rod	WP-PHJ/03
4	1	Guide Column Nut	WP-PHJ/04
5	1	Machine Screw Dome M6 x 12mm Socket	WP-PHJ/05
6	1	Push-pull Clamp Complete	WP-PHJ/06
7	1	Push-pull Clamp Adjustable Pad & Stud Assembly	WP-PHJ/07
8	4	Machine Screw Dome M5 x 10mm Socket	WP-SCW/71
9	1	Stepped Drill 9.5mm (3/8") Diameter x 150mm Long HSS	PH/DRILL/95
10	1	Depth Collar for Stepped Drill	PH/COLL/95
11	1	Snappy Square Drive Screwdriver Bit No. 2 x 75mm long	SNAP/SQ/2A
12	1	Snappy Square Drive Screwdriver Bit No. 2 x 150mm long	SNAP/SQ/2B
13	0	Screw Pocket Hole Self Tapping Dome No. 7 x 30mm Square Pack of 500	PH/7X30/500
14	1	Hex Key 2.5mm A/F	WP-AP/25
15	1	Hex Key 3mm A/F	WP-AP/03
16	1	Hex Key 4mm A/F	WP-AP/04
17	1	Face Clamp 152mm Long x 42mm Throat x 42mm Opening	PH/CLAMP/F6
18	3	Bench Fixing Screws Csk No. 8 x 25mm Pozi	WP-SCW/100
19	1	Manual	MANU/PH



**PH/JIG - SPARE PARTS DIAGRAM**

v3.0 07/2014

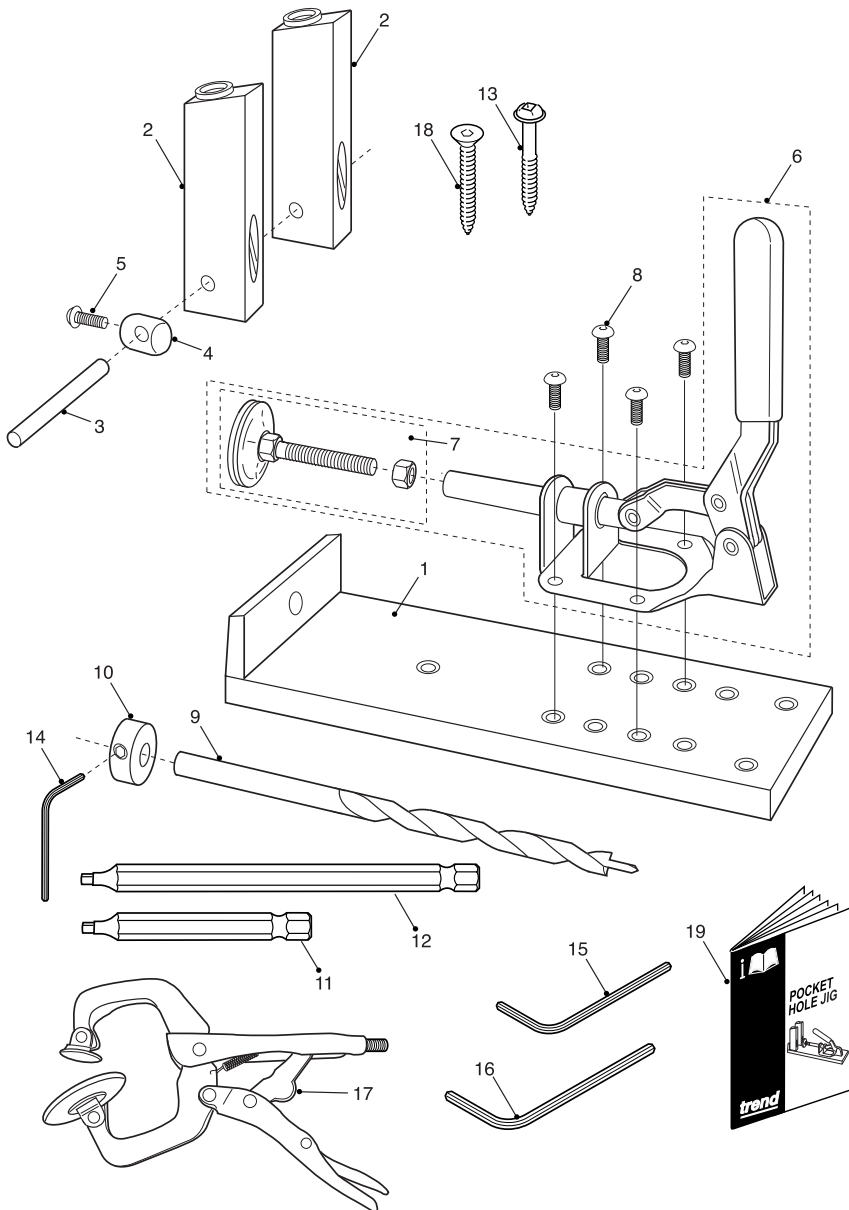

---

## **TROUBLE SHOOTING**

<b>Fault</b>	<b>Cause</b>	<b>Remedy</b>
■ Clamp will not lock in holding position.	Clamp pad not set to correct position.	Adjust clamp pad length by rotating pad, until clamp handle snaps closed when using two fingers of pressure.
■ Drill guide columns move when drilling.	Fixing screw not tight.	Tighten fixing screw with hex key.
■ Screw protrudes through face of mating piece.	Depth collar set to high causing drill bit to drill too deep.	Adjust height of collar on drill bit.
■ Workpieces will not pull together tightly when being assembled.	Occurs on very hard woods, when threads of self tapping screw are holding on both pieces of material and pushing them apart.	Clamp material more tightly or adjust collar so drill point nearly breaks through first piece of material.
■ Workpieces do not sit flush or move when being assembled.	Screws tend to follow grain of the wood.	Clamp more securely to prevent material movement when assembling. Use face clamp for edge to edge joints.

---



MANU/PH v4.0



RECYCLABLE

Trend Machinery & Cutting Tools Ltd.  
Odhams Trading Estate St Albans Road  
Watford WD24 7TR England  
**Tel: 0044(0)1923 249911**  
**technical@trendm.co.uk**  
**www.trend-uk.com**