



Pocket Hole Plug Cutter PH/PC/95



trend
routing technology

INST.PH/PC v3.0

Please read carefully before use

POCKET HOLE PLUG CUTTER REF. PH/PC/95

Thank you for purchasing this Trend product, which should give lasting performance if used in accordance with these instructions.

The pocket hole plug cutter allows a plug or pellet to be created which can then be glued into the pocket created by a pocket hole drill. The resulting plug will help to hide the screw head.

The following symbols are used throughout these instructions.



Denotes risk of personal injury, loss of life or damage to the tool in case of non-observance of the instructions.



Refer to the instruction manual of your power tool.

This cutter must not be put into service until it has been established that the power tool to be connected to this unit is in compliance with 98/37/EC (identified by the CE marking on the power tool).

INTENDED USE

This accessory is intended to be used with a fixed head pillar drill to create a plug or pellet in softwoods and non-abrasive hardwoods.

The timber will need to be held in a component holding device and the pocket hole plug cutter must be used in a pillar drill.

SAFETY

Please read and understand the safety points at the end of this instruction as well as the power tool instructions before use.

PLEASE KEEP THESE INSTRUCTIONS IN A SAFE PLACE.

The attention of UK users is drawn to The Provision and Use of Work Equipment Regulations 1998, and any subsequent amendments.

Users should also read the HSE/HSC Safe Use of Woodworking Machinery Approved Code of Practice and Guidance Document and any amendments.

Users must be competent before using our products.

Attention should be made to the HSE's Safe Use of Vertical Spindle Moulding machines Information Sheet No. 18 and any revisions.



The plug should ideally be drilled at the same angle of approach as the pocket hole drill. But as this is very difficult to achieve accurately, we recommend that the plug is drilled in line with the grain. The matching plug will be a reasonable match to the hole.

OPERATION



Work Holding Device



The component holding device is used to hold the component vertically in order for the drill to cut into the end grain. The holding device must be made from a minimum of 18mm thick MDF. The device will need to create a support which is 90° to the pillar drill work-table. The holding device should be glued and screwed together.

Once aligned beneath the plug cutter the work holding device should then be secured to the pillar drill work-table.

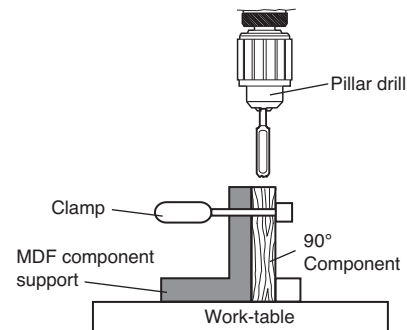

The plug cutter must be used in a pillar drill and the timber must be secured in a work holding device.

Drilling the Plug



The plug cutter can be used on both softwood and hardwood. However the drilling speed and the feed speed will need to be adjusted to reduce heat build-up.



Recommended speed 2,000rpm.

Check that the cutter is secure in the chuck and that the work holding device is holding the timber securely. Once checked, set the depth stop of the drill. The length of the plug will need to be about 40mm. However the cutter will allow a plug of maximum 51mm long to be created.

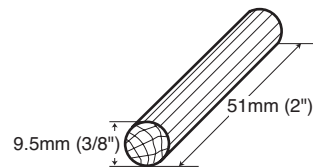

Switch on the pillar drill and gently drill into the end grain. Occasionally raise the cutter to allow waste to be ejected from the hole. Continue to drill until the required depth is reached. Release plunge and switch off the pillar drill.

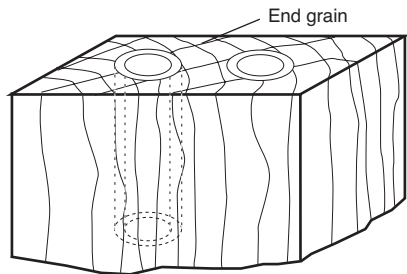

The plug can be removed from the timber by cutting across timber with a handsaw or bandsaw at the correct height.



Do not use a bench or portable circular saw to remove the plugs, as they may catch the blade tips and be ejected rapidly.

Fitting the Plug

The resulting plug is then test fitted into the pocket hole pocket. Glue is used to secure the plug into the pocket. The grain on the plug should be in the same direction as the grain on the component.

The protruding end of the plug can be removed using a handsaw. The plug should then be sanded flat.

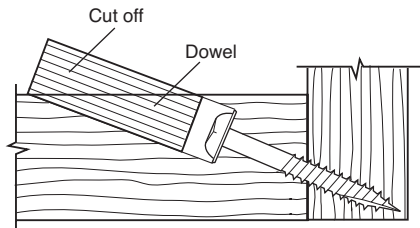
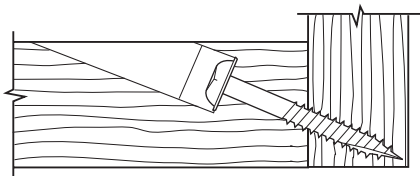

MAINTENANCE

Continual satisfactory operation depends upon proper tool care and regular cleaning.

Cleaning

- Ensure clamping surfaces are cleaned to remove dirt, grease, oil and water.
- Remove resin build-up regularly.
- Apply a rust protector to shanks.

Lubrication

- Use a PTFE dry lubricant spray on tool, to increase cutting edge life.

Storage

- Return cutter to its packaging after use.

ENVIRONMENTAL PROTECTION

Recycle raw materials instead of disposing as waste.

Packaging should be sorted for environmental-friendly recycling. The product and its accessories at the end of its life should be sorted for environmental-friendly recycling.

GUARANTEE

All Trend products are guaranteed against any defects in either workmanship or material, except products that have been damaged due to improper use or maintenance.

SAFETY POINTS

1. Disconnect pillar drill and attachment from power supply when not in use, before servicing, when making adjustments and when changing accessories such as cutters. Ensure switch is in "off" position and cutter has stopped rotating.
2. Read and understand instructions supplied with pillar drill attachment and cutter.
3. Current Personal Protective Equipment (PPE) for eye, ear and respiratory protection must be worn. Keep hands, hair and clothes clear of the cutter.
4. Before each use check cutter is sharp and free from damage. Do not use if cutter is dull, broken or cracked or if any damage is noticeable or suspected.
5. The maximum speed (nmax) marked on tool or in instructions or on packaging shall not be exceeded. Where stated, the speed range should be adhered to.
6. Keep hands, hair and clothing clear of the cutter at all times.
7. Check all fixing and fastening nuts, bolts and screws on pillar drill, attachment and cutting tool are correctly assembled, tight and to correct torque setting before use.
8. Ensure all vibrators, guards and dust extraction is fitted.
9. Ensure material is securely clamped when using a pillar drill.
10. Do not switch pillar drill on with the cutter touching the workpiece.
11. Trial cuts should be made in waste material before starting any project.
12. Repair of tools is only allowed according to tool manufacturers instructions.

Please see www.trend-uk.com/safety for more safety advice.



Our policy of continuous improvements mean that specifications may change without notice. Trend Machinery & Cutting Tools Ltd. cannot be held liable for any material rendered unusable, or for any form of consequential loss.

© Trend Machinery & Cutting Tools Ltd. 2006 E&OE
 All trademarks acknowledged

Trend Machinery & Cutting Tools Ltd.

Odhams Trading Estate St. Albans Road
 Watford WD24 7TR England

Enquiries: _____ 0800 487363

Technical Support: 0044 (0) 1923 224681

Fax: _____ 0044 (0) 1923 236879

Email: _____ enquiry@trendm.co.uk

Web: _____ www.trend-uk.com



RS 20902
 Stockholding
 & Supply



RECYCLABLE

