

**Panel Butt
Connector Template
PBT/PACK**

INSTRUCTIONS

Please read carefully before use

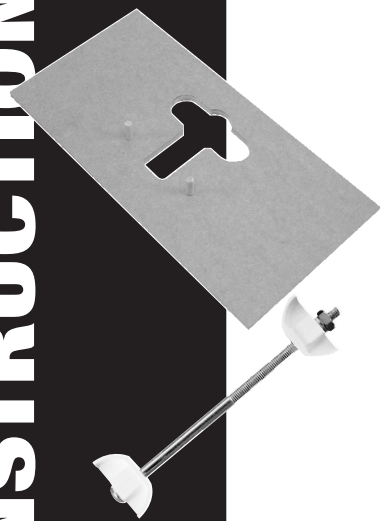

**PANEL BUTT
CONNECTOR TEMPLATE
REF. PBT/PACK**

Thank you for purchasing this Trend Panel butt Connector Template which allows kitchen worktop joints to be jointed.

Parts supplied in Set

1. Single Aperture Template 400 x 200mm (x1)
2. Location Dowels 8mm Diameter (x2)
3. Panel Butt Connectors Ref. PC/10 (pack of 10)

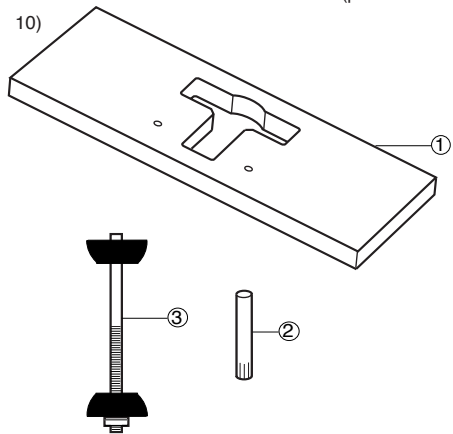

This single aperture template is designed to rout recesses into the underside of worktops for the fitting of Trend Panel Butt Connectors.

The template should be used in conjunction with a router fitted with a 12.7mm (1/2") diameter x 50mm (2") cut length, cutter Ref. 3/83D x 1/2 TC or RT/11 x 1/2 TC and a 30mm outside diameter template guide bush.

1. Initially the two location dowels should be glued into the two location holes with PVA or hot melt glue. The heads of dowels should be flush with one face of the template.

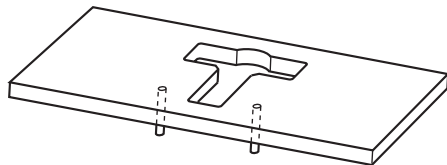

2. Lay the two worktops face down in the position to be jointed, and mark one centre line for each connector point on the underside of the worktop.

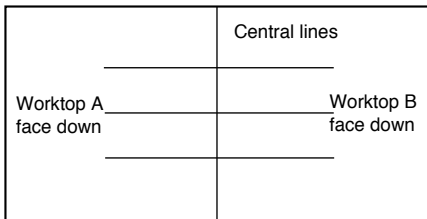

3. With the location dowels facing down and

butted up the edge of the worktop, align the centre of the aperture with the first line.

4. Set the depth stop of the router to give the required depth of cut as detailed opposite. Allow for the thickness of the template when making this setting.
5. Clamp template onto worktop with G cramps or quick action clamps and rout clockwise in 8mm depths until full depth is reached. Ensure clamps do not foul path of router base.

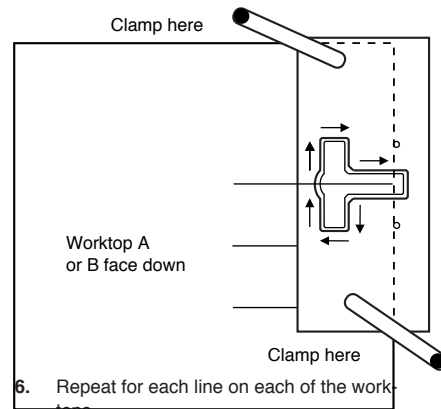

6. Repeat for each line on each of the worktops.
7. Install worktops into position and fit panel butt connectors. Tighten with 10mm A/F

spanner. The template has an elongated slot which will allow easier access for the spanner.

Worktop Thickness	Depth of Recess
30mm	22mm
40mm	28mm

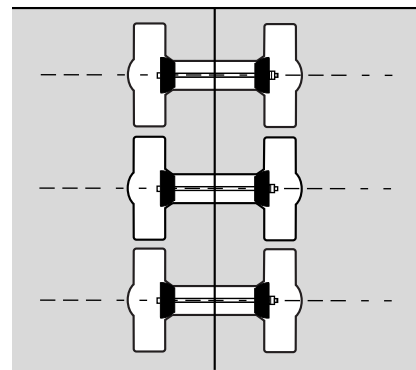

© Trend Machinery & Cutting Tools Ltd 2001 E & OE

Trend Machinery & Cutting Tools Ltd
Odhams Trading Estate St Albans Road
Watford WD24 7TR
Technical Support: 01923 224681
Fax: 01923 236879
Email: mailserver@trendm.co.uk
WWW: www.trendm.co.uk



RECYCLABLE



Safety Steps

1. Always wear eye protection such as goggles, ear protection and use effective respiratory protection.
2. Before making adjustments to the router, like changing the cutter, make sure the power is isolated correctly.
3. Before re-connecting to the mains supply, make sure the power switch on the router is in the 'off' position.
4. Do not switch on the router with the cutter in contact with the workpiece.
5. Before making adjustments always allow the cutter to stop rotating.
6. When routing keep your hands, hair and clothing clear of the cutter.
7. Make sure you follow the instructions which came with your router.
8. Ensure all visors, guards and dust extraction are fitted.
9. Trial cuts should be made in waste material before starting any project.

All Trend tooling is guaranteed against any defects in either workmanship or material, except tools that have been damaged due to improper use or maintenance.

Our policy of continuous improvements mean that specifications may change without notice. Trend Machinery & Cutting Tools Ltd cannot be held liable for any material rendered unusable, or for any form of consequential loss.