



**Modular Window  
System Trickle  
Vent Jig  
IT/MWS/JIG/B**

Please read carefully before use



**MWS ESPAGNOLETTE RECESS JIG  
REF. IT/MWS/JIG/B**

Thank you for purchasing this Trend product which should give lasting performance if used in accordance with these instructions.

The following symbols are used throughout these instructions.



Denotes risk of personal injury, loss of life or damage to the tool in case of non-observance of the instructions.



Refer to the instruction manual of your power tool.

This unit must not be put into service until it has been established that the power tool to be connected to this unit is in compliance with 2006/42/EC (identified by the CE marking on the power tool).

**INTENDED USE**

This accessory is intended to be used with a portable plunge router with suitable cutter and guide bush fitted to cut a recess for a Trickle Vent in a window sash.

**SAFETY**

Please read and understand the safety points at end of this instruction as well as the power tool instructions before use.

PLEASE KEEP THESE INSTRUCTIONS IN A SAFE PLACE.

The attention of UK users is drawn to The Provision and Use of Work Equipment Regulations 1998, and any subsequent amendments.

Users should also read the HSE/HSC Safe Use of Woodworking Machinery Approved Code of Practice and Guidance Document and any amendments.

Users must be competent in using woodworking equipment before using our products.

**ITEMS REQUIRED**

- Plunge router with suitable size collet fitted eg Ref. T10EK.
- Cutter two flute straight 12mm diameter x 50mm cut length eg Ref. 3/73DX1/2TC.
- Guide bush 30mm diameter.
- Hand tools.

**ITEMS ENCLOSED & DESCRIPTION OF PARTS**

- A. Main Plate **x1**
- B. Bracket **x1**
- C. Clamp **x1**
- D. Scribe Centre Line
- E. Instructions **x1**

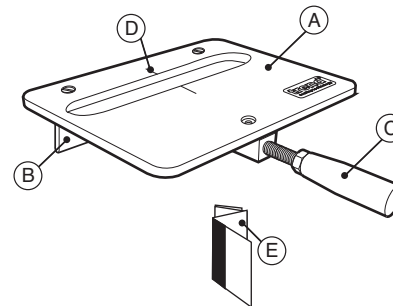

**OPERATION**



**Setting Up the Jig**

- Mark the position of the centre of the lock on the sash.
- Lay the jig on the sash and line up scribe centre line on the jig with the centre-line on the sash.

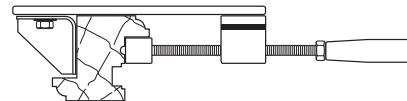

- Clamp jig in position using the integral clamp.

**Setting Up the Router**

- Isolate router from power supply.
- Fit a 30mm guide bush to router.
- Fit 12mm diameter x 50mm cut length straight two flute router cutter into router.



Ensure the jig is clamped securely to the sash before routing.

## ENVIRONMENTAL PROTECTION

Recycle raw materials instead of disposing as waste.

Packaging should be sorted for environmental-friendly recycling. The product and its accessories at the end of its life should be sorted for environmental-friendly recycling.

## GUARANTEE

All Trend products are guaranteed against any defects in either workmanship or material, except products that have been damaged due to improper use or maintenance.

© Trend Machinery & Cutting Tools Ltd. 2009 E&OE  
© All trademarks acknowledged

**Trend Machinery & Cutting Tools Ltd.**  
Odhams Trading Estate St. Albans Road  
Watford WD24 7TR England  
Tel: 0044(0)1923 249911  
technical@trendm.co.uk  
www.trend-uk.com



RECYCLABLE



## Setting the Depth of Cut

Set the router depth of cut for a maximum of 12mm deep per pass using the router depth stop.

## Routing Operation

- Place router with guide bush and cutter fitted into the slot in the jig.
- Switch on router and plunge down, move router along slot to rout out recess. At the end of the slot, release plunge.
- Return router to the start of the slot, reset plunge depth and repeat the operation. The slot depth will need to be routed in a number of passes until final depth of cut is achieved. The final pass should cut through the sash. At the end of cut, release plunge and switch off the router.
- Check slot has been routed correctly and then remove jig from sash.



The material being cut will need to be supported and clamped securely.



Regularly check knobs, handles and locking nuts are tight.

## ACCESSORIES

Only use original Trend accessories.

**Ref. 3/73DX1/2TC** Two flute straight 12mm dia x 50mm cut length.

**Ref. T10EK** 2000 watt 1/2" collet plunge router c/w with 30mm guide bush.

**Ref. GB30** 30mm guide bush.

**Ref. UNIBASE** For other makes and models of router a Unibase may be required to fit the accessory 30mm guide bush.

## SPARE PARTS

Only use original Trend spare parts. Please enquire with Trend Technical Dept.

## MAINTENANCE

The accessory has been designed to operate over a long period of time with minimum of maintenance. Continual satisfactory operation depends upon proper tool care and regular cleaning.

## Cleaning

- Keep the grooves and knob threads clear of wood dust.
- Regularly clean with a soft cloth.

## Lubrication

- Your accessory requires no additional lubrication.

## Storage

- Store accessory safely on wall hooks.

## Safety Points

1. Disconnect power tool and attachment from power supply when not in use, before servicing, when making adjustments and when changing accessories such as cutters. Ensure switch is in "off" position and cutter has stopped rotating.
  2. Read and understand instructions supplied with power tool, attachment and cutter.
  3. Current Personal Protective Equipment (PPE) for eye, ear and respiratory protection must be worn. Keep hands, hair and clothes clear of the cutter.
  4. Before each use check cutter is sharp and free from damage. Do not use if cutter is dull, broken or cracked or if any damage is noticeable or suspected.
  5. The maximum speed (n<sub>max</sub>) marked on tool or in instructions or on packaging shall not be exceeded. Where stated, the speed range should be adhered to.
  6. Insert the shank into the router collet at least all the way to the marked line indicated on the shank. This ensures at least 3/4 of shank length is held in collet. Ensure clamping surfaces are clean.
  7. Check all fixing and fastening nuts, bolts and screws on power tool, attachment and cutting tools are correctly assembled, tight and to correct torque setting before use.
  8. Ensure all visors, guards and dust extraction is fitted.
  9. The direction of routing must always be opposite to the cutter's direction of rotation.
  10. Do not switch power tool on with the cutter touching the workpiece.
  11. Trial cuts should be made in waste material before starting any project.
  12. Repair of tools is only allowed according to tool manufacturers instructions.
  13. Do not take deep cuts in one pass, take shallow passes to reduce the side load applied to the cutter.
- Please see [www.trend-uk.com/safety](http://www.trend-uk.com/safety) for more safety advice.



Our policy of continuous improvements mean that specifications may change without notice. Trend Machinery & Cutting Tools Ltd. cannot be held liable for any material rendered unusable, or for any form of consequential loss.