



Mini Routabout M/RBT

Please
read carefully
before use

MINI ROUTABOUT REF. M/RBT

Thank you for purchasing this Trend product, which should give lasting performance if used in accordance with these instructions.

The following symbols are used throughout these instructions.



Denotes risk of personal injury, loss of life or damage to the tool in case of non-observance of the instructions.



Refer to the instruction manual of your power tool.

This unit must not be put into service until it has been established that the power tool to be connected to this unit is in compliance with 98/37/EC (identified by the CE marking on the power tool).

INTENDED USE

This accessory is intended to be used with a plunge router, with suitable guide bush and cutter fitted to rout access holes in suitable thickness chipboard, plywood or sterling board floors.

Size:

Hole diameter 108mm (4 1/4").

Floor thickness 18mm (0.702") - Ref. M/RBT/1 or M/RBT/3.

Floor thickness 22mm (7/8") - Ref M/RBT/2 or M/RBT/4.



Maximum load capacity on each cover is 380 kg.



The Mini Routabout routing process is different to the standard Routabout. Please read these instructions carefully.

SAFETY

Please read and understand the safety points at end of this instruction as well as the power tool instructions before use.

PLEASE KEEP THESE INSTRUCTIONS IN A SAFE PLACE.

The attention of UK users is drawn to The Provision and Use of Work Equipment Regulations 1998, and any subsequent amendments.

Users should also read the HSE/HSC Safe Use of Woodworking Machinery Approved Code of Practice and Guidance Document and any amendments.

Users must be competent in using woodworking equipment before using our products.

ITEMS REQUIRED

- Plunge router with suitable size collet fitted
- No.2 Pozidriv® screwdriver
- Small pad saw

Ref. Unibase

For certain makes of router, a sub-base will be required to allow the guide bush to be fitted.



Please refer to Building Regulations Approved Document B, and any amendments before use of the accessory.

ITEMS ENCLOSED & DESCRIPTION OF PARTS

- A. Template **x1**
- B. Tungsten Carbide Tipped Cutter **x1**
- C. Mini Routabout Cover **x3**
- D. 30mm Plastic Guide Bush **x1**
- E. Fixing Screw **x1**
- F. Instructions **x1**

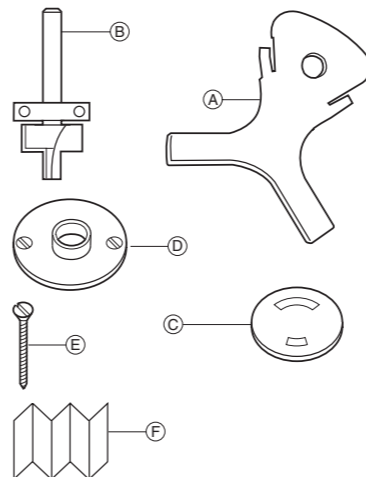

ASSEMBLY

Guide Bushes

The bush supplied with the jig is standard Trend pattern. It will fit most Trend, Elu and Dewalt routers directly.

For other makes and model of router a sub-base may be required to allow the guide bush to be fitted. The Universal sub-base Ref.

UNIBASE has been designed for use with a variety of routers; it also ensures concentricity between cutter and guide bush ensuing accuracy.

Setting up the Router

1. Isolate router from power supply.
2. Fit guide bush to router.
3. Fit router cutter into router.

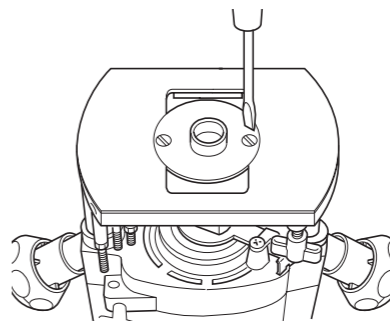

PTO

ENVIRONMENTAL PROTECTION

Recycle raw materials instead of disposing as waste.

Packaging should be sorted for environmental-friendly recycling. The product and its accessories at the end of its life should be sorted for environmental-friendly recycling.

GUARANTEE

All Trend products are guaranteed against any defects in either workmanship or material, except products that have been damaged due to improper use or maintenance.

© Trend Machinery & Cutting Tools Ltd. 2008 E&OE
® All trademarks acknowledged

Trend Machinery & Cutting Tools Ltd.
Odhams Trading Estate St. Albans Road
Watford WD24 7TR England

Enquiries: _____ 0800 487363

Technical Support: _0044 (0) 1923 224681

Fax: _____ 0044 (0) 1923 236879

Email: _____ enquiry@trendm.co.uk

Web: _____ www.trend-uk.com



5

027654 547571 >



RS 28982
Stockholding
& Supply



RECYCLABLE

trend
routing technology

INST/M/RBT v1.0

