

Dear Customer

Thank you for purchasing this Trend product, we hope you enjoy many years of creative and productive use.

Please remember to return your guarantee card within 28 days of purchase.

CONTENTS

INTRODUCTION & ACCESSORIES	2
APPROVALS	2
TECHNICAL SPECIFICATION	3
ITEMS ENCLOSED	4
DESCRIPTION OF PARTS	4-5
SAFETY	6-7
AIRSHIELD SAFETY PRECAUTIONS BEFORE USE	8
– Battery Pack Charging	8
ASSEMBLY & ADJUSTMENT	
– Battery Pack Removal & Replacement	9
– Functional Test	9
– Fitting Procedure	9-10
– Removal Procedure	10
OPERATION	10
MAINTENANCE & CARE	11-12
STORAGE	12
TRANSPORTATION	12
REPLACEMENT OF SPARE PARTS	
– Battery Pack & Safety Precautions	12
– Pre-Filter & Main Filter	13
– Face Seal	13
– Sweatband & Headband	14
– Visor Overlay	14
– Fan-Motor Unit & Visor	15
ENVIRONMENTAL PROTECTION	16
GUARANTEE	16
SPARE PARTS	
– Spare Parts List	16
– Spare Parts Diagram	1B



If you require further technical information or spare parts, please call our technical support department on 01923 224681.

INTRODUCTION

The Airshield is a lightweight Powered Respirator intended for protection against all solid dusts. This is combined with full eye and face protection from impact and chemical liquid splash.

The Airshield is powered by either one or two rechargeable battery packs inside the respirator. Air is filtered through the respirator to provide a constant flow of clean air over the face. A soft face seal ensures positive pressure is maintained within the visor and prevents debris or contaminated air entering the visor area. The visor is mounted on a fully adjustable headband providing a comfortable fit for most head sizes.

Typical use for the Airshield Respirator is the protection of individuals in Agriculture, Engineering, Pottery, Insulation, Woodworking, Dental Laboratories, Aerospace and other places where dust is present. All respirators must be used in atmospheres containing sufficient oxygen to support life (usually 17% to 23% by volume).

All parts, including filters and accessories are easily changed without the use of special tools and come packed for immediate use.

Read this manual before using the Airshield. It must be fitted and used in accordance with this manual to obtain the design performance. Use as part of your maintenance programme.

The following symbols are used throughout this manual:



Denotes risk of personal injury, loss of life or damage to the tool in case of non-observance of the instructions in this manual.

INTENDED USE

The Airshield is a lightweight Powered Respirator intended for protection against all solid dusts. This is combined with full eye and face protection from impact and chemical liquid splash. It is fitted with a 4 hour on-board battery.

ACCESSORIES

AIR/1	THP2 filter packs (packed 3)
AIR/10	THP2 filter packs (packed 1)
AIR/2	Pre-filter (packed 3)
AIR/3C	Visor overlay - clear (packed 10)
AIR/3G	Visor overlay - green anti-glare (packed 10)
AIR/4	4 hour battery
AIR/5/UK	230v charger (UK)
AIR/5/EURO	220v charger (Euro)
AIR/5/ANZ	230v charger (Australia & New Zealand)
AIR/WIPE	Visor wipes
AIR/WSP	Woodturners spare pack comprises: 1 x THP-2 filter, 3 x pre-filter, 10 x visor overlay & 1 x face seal (see catalogue)
AIR/BCP/UK	Battery and charger pack 230v (UK) Comprises: 1x AIR/4 & 1x AIR/5/UK



IMPORTANT!

Please read the operating instructions carefully and keep them together with your Airshield Respirator.



IMPORTANT!

Before use fully charge the battery for 24 hours.



IMPORTANT!

Not to be used if the contaminate is potentially explosive or highly flammable.

APPROVALS

Type approved according to European Directive 89/686/EEC by:

Inspec Certification
Upper Wingbury Courtyard
Wingrave
Aylesbury
England
NP22 4LW
Notified Body No. 0194

Visor (eye protection) approvals EN 166.

Airshield manufactured by:

Trend Machinery & Cutting Tools Ltd
Odhams Trading Estate St Albans Road
Watford
England
WD24 7TR

The visor (reference WP-AIR/07) when fitted to the respirator gives protection as detailed below:-

The visor is marked:-
TREND 2 F CE0194

Number "2" is optical class 2 - is the permissible tolerance for refractive power (EN166).

Letter "F" is the "low energy impact" relating to the protection against high speed particles (EN166).

Note that contact of the visor with your skin will not cause allergic reactions under normal conditions. It is unlikely that any contact will occur in normal conditions of use.

The frame is marked:-
TREND EN166:1995 34-F

EN166:1995 is the harmonised European Standard Number.

Number "3" is protection against droplets and splashes or liquids.

Number "4" is protection against large dust particles.

Letter "-F" is the symbol for resistance to high speed particles.

IMPORTANT!

Visor ref. WP-AIR/07 must only be used with the Trend Airshield.

TECHNICAL SPECIFICATION

Type: Respirator, powered particle filtering device.

Respiratory Approvals

Europe: Complies with European Standard BS EN146:1992 Class THP2.

UK: Suitable for use under COSHH, CAW, CLAW and IRR.

Head Protection: This is **NOT** an industrial safety helmet.

Eye Protection Approvals

Eye Protection: Complies to European Standard BS EN166:1995 Low energy impact

General

Weight: Complete with battery pack and filters but no additional accessories, 735g nominal.

Head Size: 52 to 62cm

Initial Design

Flow Rate: 180 l/min (clean filters, fully charged battery).

Min Design

Flow Rate: 140 l/min.

Duration: One battery pack will operate in excess of 4 hours.

Two battery packs will operate in excess of 8 hours.

Very High Work Rate:

EN 146 requires all manufacturers to state that at very high work rates, the pressure in powered respirators **MAY** become negative at peak inhalation.

Protection Factor: Minimum 20 assessed against EN 146.

Environmental

Range:	Storage	Use
Temperature	0°C to 45°C	-5°C to 50°C
Pressure	800 to 1300 mbar	800 to 1300 mbar
Humidity	0 - 90%	0 - 90%

(out of direct sunlight)

Abnormal Conditions:

Not for use in explosive gas atmospheres. If the fan ceases to function whilst in the contaminated area, leave the contaminated area immediately, do not remove the Respirator until you are clear of the contaminated area. Note: During this condition there will be an increase in the exhaled carbon dioxide content within the respirator.

Filter: EN 146 Class THP2 tested against Sodium Chloride aerosol 0.02 to 2 micron with a mass median particle size of 0.6 micron. For use against solid and water based aerosols only.

Battery Pack: 3.6v DC. Recharge time 14 hours from fully discharged or 1.5 hours per hour usage time. Life Nominal 900 cycles.

Battery Charger: Mains operated double insulated complying with most high integrity standards. 4.35v DC output, constant current with current limiting circuit. No known overcharge problem when batteries are left in for long periods.

Visor: EN 166 requires the visor to be stored in a clean dry area away from direct sunlight and heat, temp. 0-45°, atmospheric pressure 800-1300 mbar, humidity 0-90%

ITEMS ENCLOSED

1x Airshield complete
1x Airflow Indicator
1x 4 Hour Rechargeable Battery
1x Disposable Visor Overlay - Clear
(may be already fitted)
1x Battery Charger
1x Carry Bag
1x COSHH Record Card (UK only)
1x Instruction Manual
1x Guarantee Card

DESCRIPTION OF PARTS

- ① Cover
- ② Pre-Filter
- ③ Main Filter
- ④ Battery Pack
- ⑤ Face Seal
- ⑥ Sweatband
- ⑦ Headband
- ⑧ Visor
- ⑨ Disposable Visor Overlay (Clear)
- ⑩ Fan/Motor Unit
- ⑪ Charger
- ⑫ Airflow Indicator
- ⑬ Carry Bag
- ⑭ Knob
- ⑮ Switch
- ⑯ Ratchet

AIRSHIELD

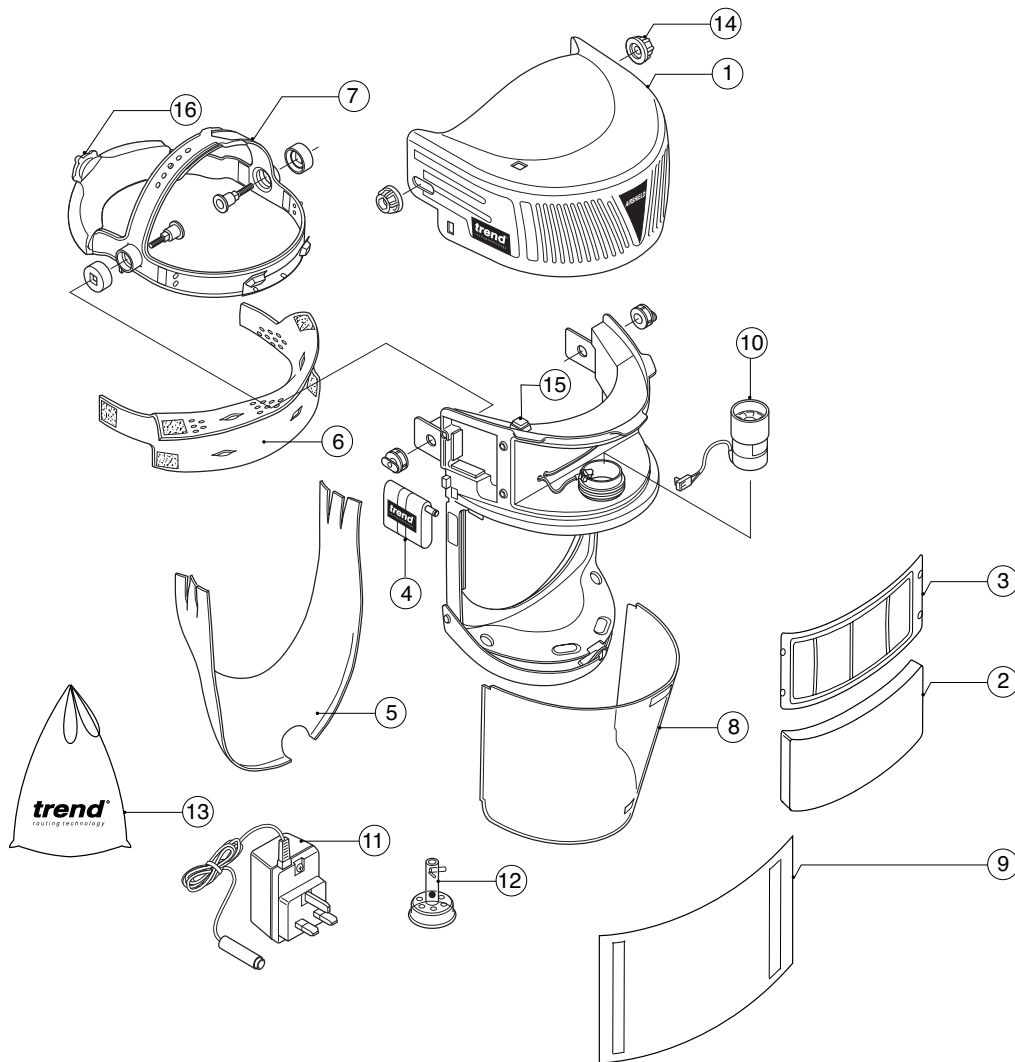

SAFETY



Observe the safety regulations in the instruction manual of the Power Tool to be used or connected to this attachment. Also observe any applicable additional safety rules. Read the following safety instructions before attempting to operate this product.

PLEASE KEEP THESE INSTRUCTIONS IN A SAFE PLACE.

The attention of UK users is drawn to The Provision and Use of Work Equipment Regulations 1998, and any subsequent amendments.

General

- Disconnect power tool, when not in use. Before servicing and when changing accessories such as cutters. Disconnect power tool and attachment from power supply. Ensure the machine is switched off before plugging tool in or connecting to a power supply.
- Always mount the power tool, accessory or attachment in conformity with the present instructions.
- Keep children and visitors away. Do not let children or visitors touch the tool, accessory or attachment. Keep children and visitors away from work area.
- Make the workshop child proof with padlock and master switch.
- Dress properly. Do not wear loose clothing or jewellery, they can be caught in moving parts. Rubber gloves and non-skid footwear is recommended when working outdoors. Wear protective hair covering to contain long hair.
- Consider working environment. Do not use the product in the rain or in a damp environment. Keep work area well lit. Do not use power tools near gasoline or flammable liquids. Keep workshop at a comfortable temperature so your hands are not cold.
- The accessory or attachment must be kept level and stable at all times.
- Keep work area clean. Cluttered workshops and benches can cause injuries
- Use the attachment with the power tools and accessories specified in this manual only. Do not force the tool or attachment to do a job for which it is not designed.
- Secure idle tools. When not in use, tools should be stored in a dry and high or locked up place, out of reach of children.
- For best control and safety use both hands on the power tool and attachment. Keep both hands away from cutting area. Always wait for the spindle and cutter to stop rotating before making any adjustments.
- Always keep guards in place and in good working order.
- Remove any nails, staples and other metal parts from the workpiece.
- Maintain tools and cutters with care. Keep cutters sharp and clean for better and safer performance. Do not use damaged cutters. Follow instructions for lubricating and changing accessories. Keep handles dry, clean and free from oil and grease.
- Maintain accessories. Do not use damaged accessories. Only use accessories recommended by the manufacturer.
- Check damaged parts. Before operation inspect the attachment, the power tool, the cable, extension cable and the plug carefully for signs of damage. Check for alignment of moving parts, binding, breakage, mounting and any other conditions that may effect its operation. Have any damage repaired by an Authorised Service Agent before using the tool or accessory.
- Do not use tool if switch does not turn it on or off. Have defective switches replaced by an Authorised Service Agent.
- Don't over reach. Keep proper footing and balance at all times.
- Don't abuse the cable. Never carry power tool or accessory by cord or pull it to disconnect from the socket. Keep cord from heat, oil and sharp edges. Always trail the power cord away from the work area.
- Connect dust extraction equipment. If devices are provided for the connection of dust extraction and collection facilities, ensure these are connected and properly used.
- Check all fixing and fastening nuts, bolts and screws before use to ensure they are tight and secure. Periodically check when machining over long periods.
- Stay alert. Watch what you are doing. Use common sense. Do not operate tools when you are tired, under the influence of drugs or alcohol.
- Personal Protective Equipment (PPE). All PPE must meet current UK and EU legislation.
- Do not leave tools running unattended. Do not leave tool until it comes to a complete stop.
- Always clamp workpiece being machined securely.
- Only use cutting tools for woodworking that meet EN847-1/2 safety standards, and any subsequent amendments.

Routing Safety

- Disconnect router power tool. When not in use, before servicing and when changing accessories such as cutters, disconnect router and attachment from power supply.
- Ensure router cutter has stopped rotating before changing it. Never use the spindle lock as a brake.
- Remove adjusting keys and spanners. Form the habit of checking to see that keys and adjusting spanner are removed from the router tool, cutter and attachment before turning router on. Make sure cutter can rotate freely.
- Check all ball bearing and blade fixing screws before use to ensure they are tight and secure. Periodically check when machining over long periods.
- When using a template guide bush ensure it cannot come into contact with collet and nut.
- Noise. Take appropriate measures for the protection of hearing if the sound pressure of 85dB(A) is exceeded. Routing sound pressure may exceed 85dB(A), so ear protection must be worn.

- Eye protection. Wear safety goggles, spectacles or visors to protect the eyes from ejected waster particles.
 - Respiratory protection. Wear a face or dust mask, or powered respirator. Dust masks/filters should be changed regularly.
 - Do not switch router on with the cutter touching the workpiece.
 - The direction of routing must always be opposite to the cutter's direction of rotation.
 - After work, release the router plunge and allow spindle to stop rotating before putting machine down.
 - Check before cutting that there are no obstructions in the path of the router. When cutting through the full thickness of the workpiece, ensure there are no obstacles beneath workpiece, and that a sacrificial work surface is used.
- Cleaner[®]. The use of a dry lubricant (Trendicote[®] PTFE) will act as a preventative. Do not use PTFE spray on plastic parts.
- Cutter shanks should be inserted into the collet to the mark line on the shank. This ensures that at least $\frac{3}{4}$ of the shank length is held in the collet. Do not over-tighten the collet nut as this will score the shank and create a weakness and fracture point.
 - Observe the correct assembly instructions in the router instruction manual for fitting the collet and nut. Observe the router power tool manual instructions on fitting cutters correctly.
 - It is advisable to periodically check the collet and collet nut. A worn, distorted or damaged collet can cause vibration and damage the shank, and should be replaced. Worn collet nuts should be replaced.
 - Do not take deep cuts in one pass; take several shallow or light passes to reduce the side load applied to the cutter. Too deep a cut in one pass can stall the router.
 - Very small diameter cutters must be handled and used with care.
 - Always return cutter to its packaging after use.
 - Should you experience excessive vibration during use stop immediately. Have the eccentricity of the router, router cutter and clamping system checked.
 - All fastening screws and nuts should be tightened using the appropriate spanner or key in accordance with the manufacturers instructions.
- Ensure a No-Volt Release Switch is fixed to or adjacent to the attachment and that it is used correctly.
 - Check the direction of the workpiece is always opposite to the cutter's direction of rotation.
 - Do not use awkward or uncomfortable hand positions.
 - Do not reach underneath table or put your hands or fingers at any time in the cutting path while tool is connected to a power supply.

Useful Advice When Routing

- Judge your feed rate by the sound of the motor. Feed the router at a constant feed rate. Too slow a feed rate will result in burning.
- Take many light passes rather than one deep cut to reduce the side load applied to both router and router cutter.
- Trial cuts should be made on waste material before starting any project.
- When using some attachments including a router table or dovetail jig, the use of a fine height adjuster is highly recommended.
- When using a template guide bush, ensure there is sufficient clearance between cutter tip and inside edge of bush. Ensure cutter and guide bush are concentric.

Router Cutter Maintenance

- Composite cutting tools (brazed tip) must be maintained by a competent person i.e. a person of training and experience, who has knowledge of the design requirements and understands the levels of safety to be achieved.
- The design of composite tools must not be changed in the process of maintenance.
- Replacement parts must meet Trend specification.
- Tolerances which ensure correct clamping by the collet shall be maintained.
- When re-grinding the tool, care must be taken not to cause weakening of the body or the connection between the cutting edge and the body.

Additional Safety Rules For Router Cutters

- Cutting tools are sharp. Care should be taken when handling them.
- Always use cutters with a shank diameter corresponding to the size of the collet installed in your tool.
- Always run router cutters at the spindle speed recommended and marked accordingly. Ensure cutter has reached correct speed before entering workpiece. Recommended speeds can be found on the packaging, in cutter instructions or in the Trend Routing Catalogue.
- Always use router cutters in a router. Router cutters must not be used in a drill. Drill and boring bits must not be used in a router. Router cutters must only be used for the material cutting application for which they are designed. Do not use on metal or masonry.
- Never use cutters with a diameter exceeding the maximum diameter indicated in the technical data of the power tool or attachment used.
- Do not drop cutters or knock them against hard objects. Do not use cutters that are damaged.
- Cutters should be kept clean. Resin build up should be removed at regular intervals with Resin

Using Routers In A Fixed Position

- After work, release the router plunge to protect the cutter.
- Always use a push-stick or push-block for last 300mm of the cut.
- Whenever possible use a work holding device or jig to secure component being machined.
- Ensure attachment is securely fitted to the workbench, with table surface at approximately hip height.

AIRSHIELD SAFETY PRECAUTIONS

- Control Of Substances Hazardous to Health (COSHH) recommend that Respiratory Protective Equipment should be stored in a cool dry place.
- For adequate protection the Airshield must fit or be adjusted to the size of the head.
- DO NOT clean with proprietary cleaning media or solvents, follow the instruction in manual.
- DO NOT apply paint, solvents, adhesives or self-adhesive labels which are not approved by Trend.
- DO NOT use Airshield without pre-filter and main filter fitted, with damaged seals and/or damaged visor.
- DO NOT use replacement parts except those supplied by Trend Machinery & Cutting Tools Ltd.
- To maintain the full efficiency of the Airshield, there must be no alteration to the structure or its component parts.
- When using two battery packs always fit two fully charged replacements.
- Toxic Dusts on the respirator or filters from usage should be handled in a safe manner in accordance with your chemical or material suppliers instructions. Used filters to be disposed of safely in the same manner.

If further information is required with regard to Airshield, please contact Trend Machinery & Cutting Tools Ltd.

BEFORE USE

Charge the battery pack/packs before use. Ensure the respirator is correctly assembled with pre-filter, main filter and either one or two fully charged battery packs fitted.

Battery Pack Charging



IMPORTANT!

Battery pack must be initially charged for 24 hours.

The Powered Respirator is supplied with one rechargeable battery pack for four hours duration.

For eight hours duration an additional rechargeable battery pack and battery charger is required.

Check that the voltage shown on the charger is suitable for the mains supply. A thermal fuse protects the charger against short circuiting and overloading.

Push the battery pack connector into the charger socket and plug the charger into the AC supply socket. The light on the charger confirms that the battery pack is charging.

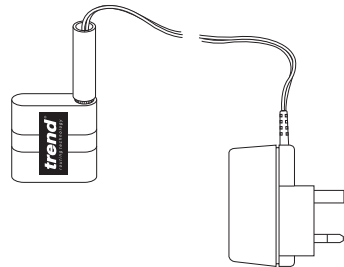

Battery packs should be initially charged for 24 hours and 14 hours thereafter when fully discharged. A 3.5 hour charge will enable 1 hour of usage. Full working capacity of the battery will not be achieved until the battery has been through 3 or 4 complete charging cycles. Please note the light will not extinguish when a full charge has been achieved.



IMPORTANT!

The charger must be disconnected from the mains supply when not in use.

After the charging period, withdraw the charger from the AC supply socket and disconnect the battery pack from the charger.

ASSEMBLY & ADJUSTMENT

Battery Pack Removal and Replacement

Release the cover by lifting the left and right sides to disengage the lugs then pull forward and lift. The battery housings are located on either side of the main filter. Use two fully charged battery packs for eight hours duration or one battery pack for four hours duration. Plug a fully charged battery pack into the connector and push it down into the housing. Repeat for the opposite side if two battery packs are required. Lower the cover and push backwards to engage the lugs into the holes. Ensure the lugs are fully engaged in the holes.

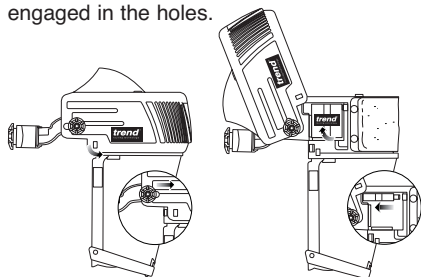

Functional Test

The purpose of this test is to ensure that the airflow through the respirator is in excess of Airshield minimum design value of 140 litres per minute. Proceed as follows:

- Invert the Airshield and fit the air flow indicator over the fan-motor unit, ensure it is firmly pushed against the grommet.
- With the fan-motor unit running, hold the Airshield so that the air flow indicator tube is vertical and the holes around the base of the air flow indicator are not obstructed. The red ball must be at the top of the tube to ensure the minimum design flow rate is being exceeded.



IMPORTANT!

When opening and closing top cover ensure knobs are loose, tabs are released and cover is slid forward. This prevents filters from rubbing against each other.

If the flow rate is not sufficient, replace or charge battery pack/packs and/or change the main filter and re-test.

After completing the functional test, switch the Airshield off and remove the air flow indicator.

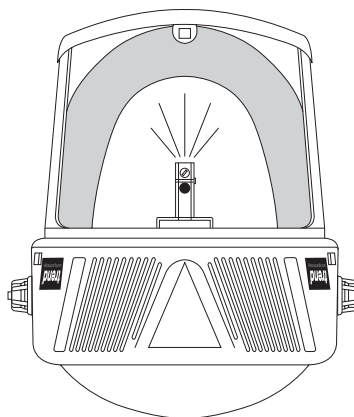

Fitting Procedure

Press and turn the ratchet knob anti-clockwise to enlarge the headband and lift the visor towards the back of the headband.

Fit the Airshield onto the head by entering the head into the headband.

Switch the fan-motor unit on and lower the visor over the face.

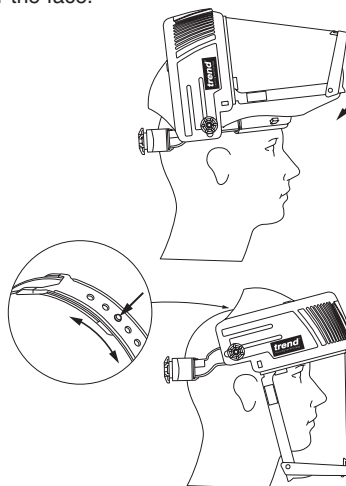

AIRSHIELD

Press and turn the ratchet knob clockwise until a secure and comfortable fit is achieved. When removing, if necessary press and turn the ratchet knob anti-clockwise to loosen the headband.

Adjust the height of the visor as follows:

- Remove the Airshield.
- Press the stud through the hole on top half of headband.
- Slide the lower half to increase or decrease the height.
- Re-fasten headband by pushing the stud through the nearest hole and check the height of the visor when worn.
- Repeat above until a correct fit is achieved.



WARNING!

Ensure that the unit is pivoted down fully so that the headband stops are against the main fan housing. The plastic headband lugs are designed to limit the movement of the visor to the face.

Adjusting the height will affect the fit around the chin.

Adjusting the face seal will affect the fit at the sides.

Ensure that the face seal around the chin and sides is pulled rearwards such that the seal deforms away from the frame and visor and not towards it.

Check the fit of the face seal in a mirror and/or run a finger around the line of the face seal to ensure contact.



WARNING!

At very high work rates, the pressure within the Airshield may momentarily become negative at peak inhalation.



WARNING!

Vacate the contaminated area immediately if the airflow is reduced or stops.



IMPORTANT!

If protective clothing is worn, ensure the bottom of the visor is not obstructed.

Removal Procedure



WARNING!

Vacate from contaminated area before removing the Airshield.

- Raise the visor and switch the fan-motor unit off.
- Lift the Airshield from the head.
- After finishing using the Airshield follow the maintenance procedures.

OPERATION

The switch (A) operates the fan-motor unit (B), powered by rechargeable battery pack(s) (C), which draws air (D) through the pre-filter (E) to remove larger particles of dust before being drawn through the main filter (F). The filtered air (G) is passed down over the face. Exhaled breath (H) leaves the respirator through holes in the bottom of the visor frame.

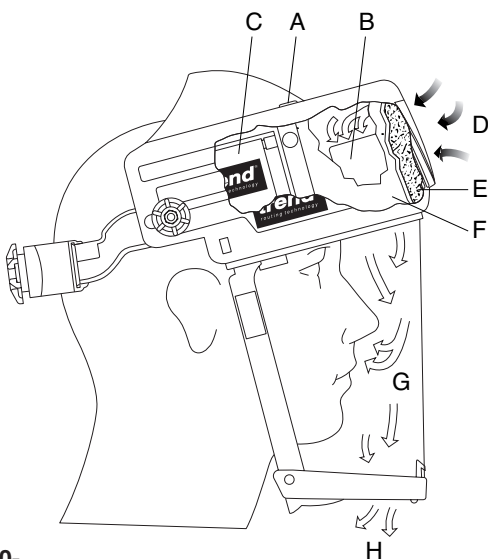

MAINTENANCE AND CARE

After using the Airshield follow the procedure below:



WARNING!

Airshield should not be cleaned with compressed air, solvents, sterilising by heat or autoclaving, as this will cause damage.

Precautions are to be taken to prevent inhalation of harmful dust or contaminant on the surface or retained on the filters.

- Carefully remove bulk contamination from the Airshield and wipe down with a damp cloth containing a mild detergent solution.
- Clean and sterilise all Airshield parts by wiping down the visor, face seal and headband with visor wipes (ref. AIR/WIPE) (Sodium Hypochlorite or Ethylene Oxide Gas have also been proved effective).



WARNING!

Gamma sterilisation is effective but causes embrittlement of plastic components and is not recommended.

- Release the cover by lifting the left and right lower sides to disengage the lugs then pull forward and lift.
- Remove the pre-filter and main filter as described. Dispose of in accordance with local health and safety regulations.
- Remove battery pack(s). Ensure battery pack is clean and recharge.
- Wipe down with a damp cloth containing a mild detergent solution to remove any loose dust from inside the cover. Do not apply pressure to the fan blades, to clean use a soft brush.
- Fit replacement pre-filter and main filter.
- Fit fully charged battery pack/packs.
- Operate the switch to check the function of the fan-motor unit.
- Carry out the functional test.

Replace if deficient after the following checks:

1. Excessive abrasion and scratches on the visor.
2. The face seal for its seal to the visor and for holes.
3. Fit and fastenings to the headband.



IMPORTANT!

Scratched or damaged oculars (visor) may not offer full protection and therefore should be replaced.

Specific instructions for cleaning and disinfection of visor

Clean regularly with a damp cloth - do not use hydrocarbons, chemicals, cleaning fluids or solvents on the visor. If necessary, a mild solution of washing-up liquid and warm water may be used.

Routine Checks

The expected life of the visor is approximately 3 years if well maintained and cleaned. (Care must be taken not to scratch the visor).

This manual contains relevant guidance on routine maintenance, however, you may wish to introduce additional checks as required by COSHH. The following table shows the frequency of these checks.

Operation	Frequency
Clean Internally and Externally	Daily
Visual Inspection	Daily
Charge Battery Pack/Packs	Daily
Functional Test*	Daily, Weekly and Monthly

* Remarks: Dust from wood, grain and cement may suit more frequent replacement of pre-filter to extend the life of the main filter. No filter should be left in the hood/helmet for more than 1 month if in daily use or 3 months if used infrequently.

Monthly - All items checked and signed by Operator.

Quarterly - All items checked and signed by Supervisor.

Symptom	Cause	Remedy
Reduced airflow	Cover air holes blocked	Clear air holes
	Pre-filter clogged	Fit a new pre-filter
	Main filter clogged	Fit a new main filter
	Battery flat	Fit a recharged battery pack(s)
No airflow	Airshield switched OFF	Press switch to ON
	Switch faulty	Return to manufacturer
	Battery pack not fitted	Fit a fully charged battery pack
	Battery pack connection	Push fully home
	Battery pack discharged	Fit a fully charged battery pack
	Fan-motor unit failure	Fit replacement fan-motor unit

STORAGE

The Airshield should be placed in the carry bag, stored within a temperature range of 0°C to 45°C and out of direct sunlight. Replacement filters are to be left in their sealed bags and expiry dates to be checked regularly.

TRANSPORTATION

The complete respirator should be transported in the carry bag provided. Good quality commercial packing should be used.

REPLACEMENT OF SPARE PARTS

Replacement parts and accessories supplied by Trend Machinery & Cutting Tools Ltd. should only be used. The use of accessories not supplied by Trend Machinery & Cutting Tools Ltd. will not be guaranteed and invalidate such National approvals as held by Trend Machinery & Cutting Tools Ltd. Modifications to the Airshield will make the approvals invalid and the use illegal under National Laws and Guidance.

Trend Machinery & Cutting Tools Ltd. replacement parts and accessories, must only be used with the Trend Airshield.

Battery Pack

- Release the cover by lifting the left and right lower sides to disengage the lugs then pull forward and lift.
- Insert finger into housing cut-out, lift battery pack and unplug from connector.
- Plug a fully charged battery pack into the connector. Push the battery pack down into the housing.
- If two battery packs are fitted repeat for opposite side. Lower the cover and push backwards to engage the lugs into the holes. Ensure the lugs are fully engaged in the holes. Carry out a functional test.

Battery Safety Precautions: Nickel-Metal Hydride AA Cell.



Never dispose of the battery pack by burning. All Ni-MH cells are subject to special waste disposal.

Always use the approved charger.

DO NOT 'short' the battery contacts.

DO NOT attempt to break into the battery case.

If the battery case breaks accidentally, avoid contact with contents. Wash contaminated skin with lots of water and seek medical attention if necessary.

Pre-Filter

- Release the cover by lifting the left and right lower sides to disengage the lugs then pull forward and lift.



WARNING!

Precautions are to be taken to prevent inhalation of harmful dust or contaminant retained on the pre-filter and inside the cover.

- Pull pre-filter away from inside the cover and dispose of in accordance with local health and safety regulations. Never re-use a pre-filter.
- Wipe down with a damp cloth to remove any loose dust from inside the cover.
- Attach the coarse side of the replacement pre-filter onto the hook fastener strips inside the cover. Lower the cover and push backwards to engage the lugs into the holes. Ensure the lugs are fully engaged in the holes. Carry out a functional test.



IMPORTANT!

When opening and closing top cover ensure knobs are loose, tabs are released and cover is slid forward. This prevents filters from rubbing against each other.

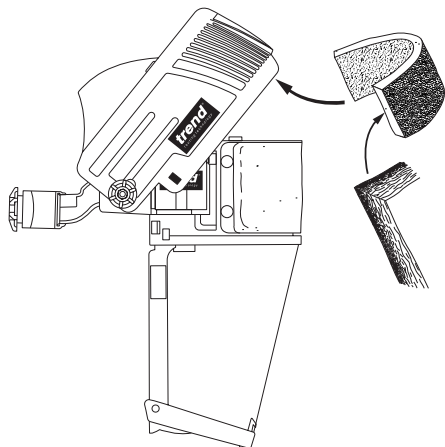

Main Filter

- Release the cover by lifting the left and right lower sides to disengage the lugs then pull forward and lift.



WARNING!

Precautions are to be taken to prevent inhalation of harmful dust or contaminant retained on the main filter and inside the cover.

- Pull the corners of the main filter to release the four press studs from the housing.
- Dispose of in accordance with local health and safety regulations. Never re-use a main filter.
- Wipe down with a damp cloth to remove any loose dust from inside the cover and housing.
- Fit a new main filter by attaching the two press studs onto the housing. Support the housing and press along the main filter edges, attach the other end onto the two press studs. Ensure the filter seal is fully seated on the housing. Lower the cover and push backwards to engage the lugs into the holes. Ensure the lugs are fully engaged in the holes. Carry out a functional test as described previously.

Face Seal

- Pull the face seal away from the hook fastener strip on visor frame.
- Establish the centre of the replacement face seal and attach the brushed nylon side onto the hook fastener strip on the bottom of the visor frame. Continue attaching the face seal to the visor frame and ensure no gaps are on the end of the face seal and visor frame.
- Adjust the position of the face seal to achieve close contact around the face.

AIRSHIELD

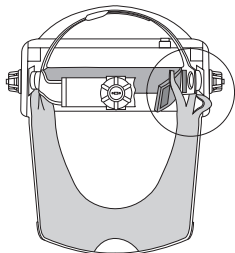
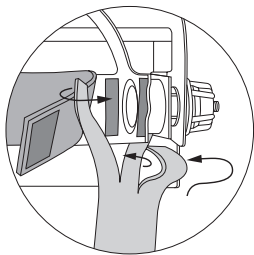

WARNING!

The knob assembly for the headband is adjusted to relieve pressure to the temples.

Sweatband

- Pull apart to separate hook fasteners and remove the sweatband from the headband. Replacement of the sweatband is the reverse of the above procedure. Ensure the foam surface is fitted against the headband and the slits are fully fitted over the headband.

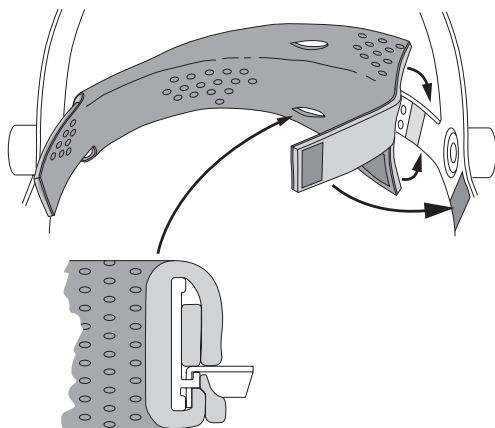

Headband

- Pull apart to separate hook fasteners to remove the sweatband from the headband.
- Detach each end of the face seal from the headband.
- Unscrew and remove the knob (4). Push the pivot pin (1) out through the cover washer (3), torque washer (2) and headband. Repeat for the opposite side to release the headband and remove the torque washers (2).
- Replacement of the headband is the reverse of the above procedure. Ensure the torque washers (2) are assembled onto the headband correctly.

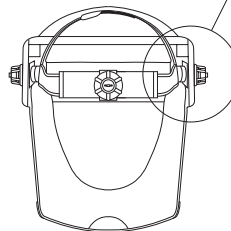
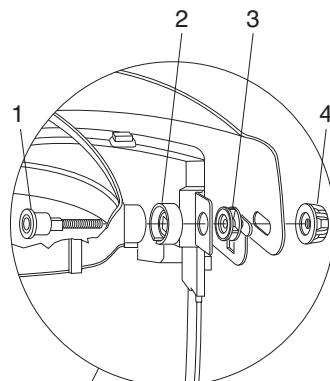

Visor Overlay

- Peel away visor protector and ensure visor surface is clean.
- Peel backing paper from adhesive strips on replacement visor protector. Position centrally onto visor surface, press down adhesive strips and remove protective paper.

Fan-Motor Unit

- Remove the main filter and battery pack/packs.
- Disconnect fan-motor unit plug from socket (flip-up locking pin on connector male and pull apart socket). Withdraw the fan-motor unit from retaining grommet.
- Replacement of the fan-motor unit is the reverse. Of the above procedure (note fan orientation). Fitting will be made easier with the visor removed and with the use of a water based lubricant such as liquid soap. Apply a small amount of lubricant around the inside of the retaining grommet before insertion of the fan. Carry out a functional test.



IMPORTANT!

Hold the fan by the sides only, do not push or apply any pressure to the fan blades.

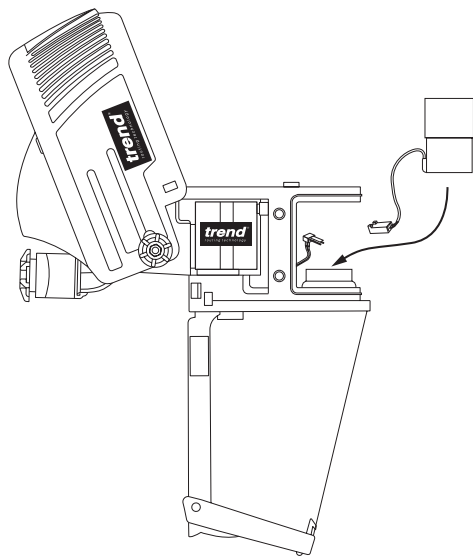

Visor

- Disengage tab from centre of visor and lower the flap. Carefully press the sides of the visor and lift it from the visor frame.
- Flex replacement visor and insert the top and sides into the visor frame ensuring that the top visor tabs slide outside of the frame. Swing the bottom of the visor into place, lift the flap and engage the latch through the visor centre hole.

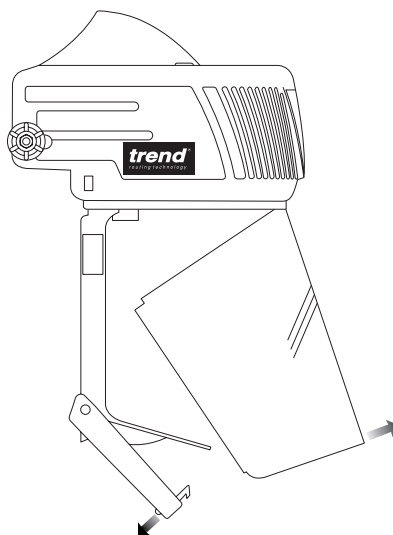

ENVIRONMENTAL PROTECTION

Recycle raw materials instead of disposing as waste.

Accessories and packaging should be sorted for environmental-friendly recycling.



Separate collection. This product must not be disposed of with normal household waste.

Local regulations may provide for separate collection of electrical products from the household, at municipal waste sites or by retailer when you purchase a new product.

Please call Trend Technical Support 01923 224681 for advice as to how to dispose of unwanted Trend electrical product in an environmentally safe way.

Rechargeable batteries and the environment.

This unit uses Nickel-Metal Hydride (Ni-MH) batteries. When the battery pack needs replacing, we recommend the following:-

- Discharge the energy from the batteries by running the batteries down completely, and then remove them from the respirator.
- Ni-MH cells are recyclable; so do not throw them away with your household waste. They may end up in an incinerator or landfill, which must be avoided.
- Instead, take the batteries to a Trend Service Agent, your local distributor or a local recycling station. If necessary, contact your local municipality for disposal information. The collected batteries will be disposed of properly and/or used for recycling purposes

GUARANTEE

The unit carries a manufacturers guarantee in accordance with the conditions on the enclosed guarantee registration card.

For the location of your nearest Trend Service Agent, please call the telephone number at the back of this manual.

AIRSHIELD - SPARE PARTS LIST			V4.0 05/2002
No.	Qty.	Desc.	Ref.
1	1	Fan/Motor	WP-AIR/01
2	1	Airflow Indicator	WP-AIR/02
3	1	Face Seal	WP-AIR/03
4	1	Headband	WP-AIR/04
5	1	Sweatband	WP-AIR/05
6	1	Carry Bag	WP-AIR/06
7	1	Visor	WP-AIR/07
8	1	Cover	WP-AIR/08
9	1	Rear Comfort Pad	WP-AIR/09
10	-		
11	2	Pivot Pin	WP-AIR/11
12	2	Cover Washer	WP-AIR/12
13	2	Torque Washer	WP-AIR/13
14	2	Knob	WP-AIR/14
15	-	-	-
16	1	Charger 230v UK - PLP1100	AIR/5/UK
	1	Charger 220v Euro - PLP1110	AIR/5/EURO
	1	Charger 230v Australia/New Zealand - PLP 1130	AIR/5/ANZ
17	1	Battery 4 Hour - 3.6 volt DC	AIR/4
18	0	Visor Overlay - Clear (pack of 10)	AIR/3C
19	0	THP2 Filter (pack of 3)	AIR/1
20	0	Pre-Filter (pack of 3)	AIR/2
21	1	COSHH Record Card	LEAF/AIR/CRC
22	1	Manual	MANU/AIR

AIRSHIELD - SPARE PARTS DIAGRAM

v4.0 05/2002

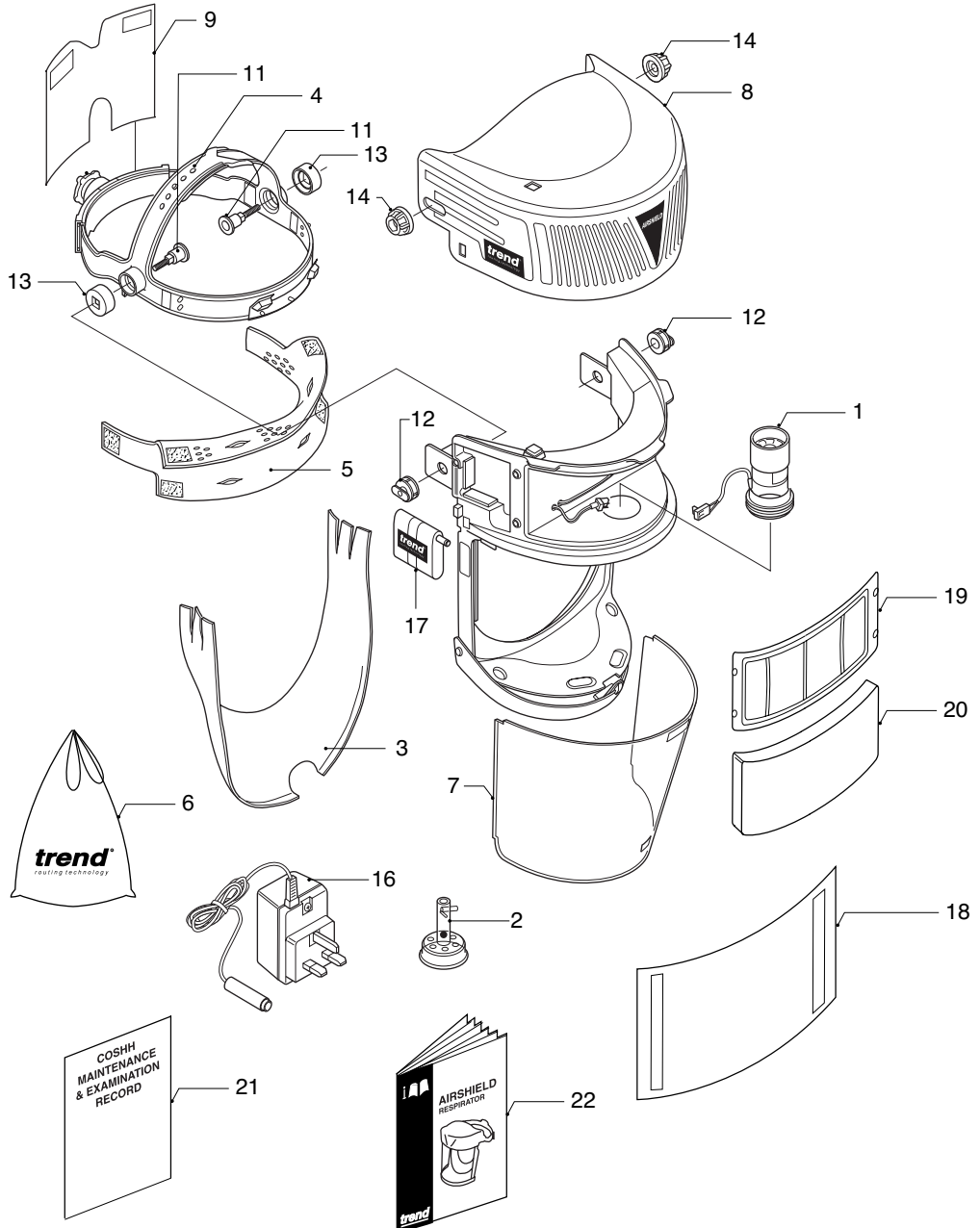



MANU/AIR v5.0



RECYCLABLE

Trend Machinery & Cutting Tools Ltd.

Odhams Trading Estate St Albans Road
Watford WD24 7TR England

Enquiries: _____ 0800 487363

Technical Support: _____ 0044 (0) 1923 224681

Fax: _____ 0044 (0) 1923 236879

Email: _____ enquiry@trendm.co.uk

Web: _____ www.trendmachinery.co.uk

© Copyright Trend 2005. No part of this publication may be reproduced, stored or transmitted in any form without prior permission. Our policy of continuous improvement means that specifications may change without notice. Trend Machinery and Cutting Tools cannot be held liable for any material rendered unusable or any form of consequential loss. E&OE

®All trademarks acknowledged.

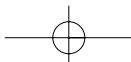



AIRSHIELD



trend[®]
routing technology

RESPIRATOR APPROVED TO EN146:1991
VISOR APPROVED TO EN166:1995