

PRECISION BENCH STONES

PRECISION FLAT
± 0.0005"
flatness

A range of precision bench stones for all your sharpening needs. ±0.0005" flatness. Suitable for plane blades, chisels, spindle knives, carving, knives and domestic.

7" X 2-1/2" DOUBLE-SIDED BENCH STONE

A double-sided fine/coarse 2-1/2" wide bench stone, ideal for plane irons and chisels. Precision flatness enables sharpening of Euro block knives. Supplied with a fabric tool holder, cleaning block and non-slip mat.

Grade	Grit	Micron
◆ Fine	1000	11
◆ Coarse	340	45

U*DWS/B7/FC

Size: 7" x 2-1/2" x 3/8"



NEW

8" X 3" DOUBLE-SIDED WORKSHOP BENCH STONE

A double-sided fine/coarse workshop stone. Ideal for up to 3" plane irons and chisels. Supplied with fabric tool holder, non-slip mat and cleaning block.

Grade	Grit	Micron
◆ Fine	1000	11
◆ Coarse	340	45

U*DWS/W8/FC

Size: 8" x 3" x 1/4"



8" X 3" SINGLE-SIDED WORKSHOP BENCH STONES

Single-sided workshop stones. Ideal for up to 3" plane irons and chisels. Supplied with fabric tool holder, non-slip mat and cleaning block.

U*DWS/W8/F

Grade	Grit	Micron
◆ Fine	1000	11

U*DWS/W8/C

Grade	Grit	Micron
◆ Coarse	340	45

NEW

U*DWS/W8/X

Grade	Grit	Micron
◆ Extra coarse	220	75

Size: 8" x 3" x 1/4"



DIAMOND FILES & STEELS

Suitable for all shaped tooling, carving and turning tools, spindle knives, pruners, domestic, kitchen, hunting and hoof knives. File metals, plastics and wood.

NEW

6" TAPERED FILE

Flat top and convex back. For all hand tools, woodworking, gardening and domestic applications.

Grade	Grit	Micron
◆ Fine	600	25

U*DWS/TF6/F

Size: 10-5/8" overall with 6" diamond length.

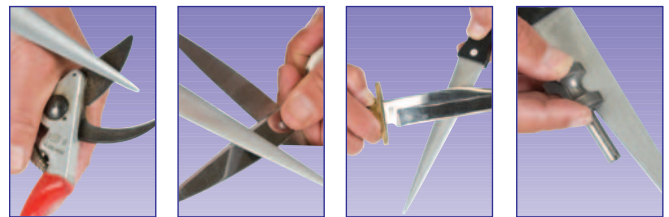
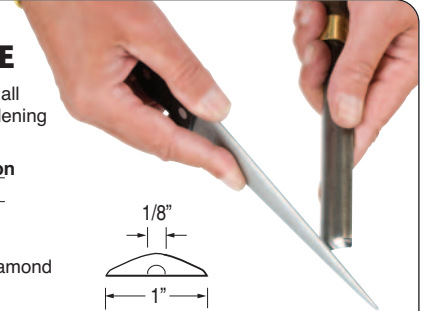
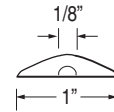

NEEDLE FILE SET

Four pack of needle files for carving tools, small tools and removing welds. Use to file metals, plastics and wood. As used in the British aerospace industry.

- Flat
- △ Half round/taper/flat
- △ Triangular/taper
- Round/taper

Grade	Grit	Micron
◆ Fine	600	25

U*DWS/NFPK/F

Size: 6-5/16" overall with 3" diamond length.

