

INDUSTRIAL TOOLING



NEW ADDITIONS

trend[®]
Industrial tooling

CNC MACHINING

New series of disposable tip router cutters for smaller CNC machines.

The main advantages of this new tooling is the compact design and light weight which won't overload a smaller CNC machine.

- All the tools are supplied with disposable inserts, so there is no need for re-grinding.
- The tool dimensions are always constant and the machine programme does not need to be altered.
- There are a number of different tools available for chamfer cuts in 11 different angles, ball groove cutters, raised panel and profile/counter profile cutters.



Grooving & Sizing



Frame & Panel Door

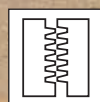

Jointing



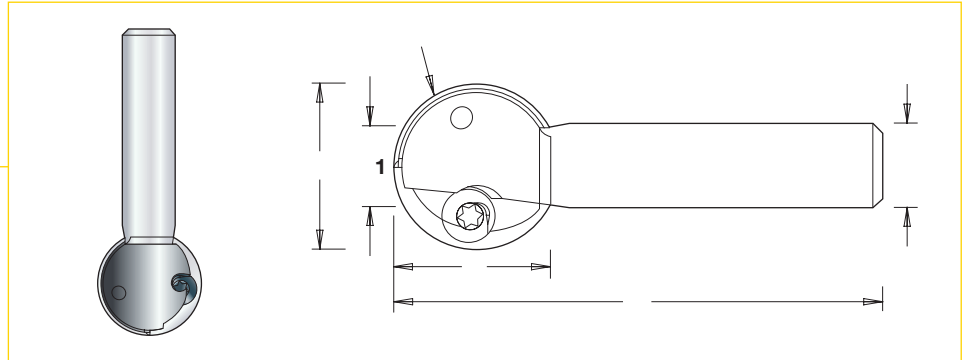

Disposable Insert Ball Groover Router Cutter

Disposable insert Ball Groover router cutter complete with one or two cutting flutes. Suitable for 3D carving and routing of electrical wire installation slots in softwood, hardwood and man-made boards. For use on routers and light machining centres with or without CNC control. Please note: A groove at the D1 width should be run with a straight router cutter before running the ball groove.



1							
12 7	10 3	6 35	106 362 8	10 3	66 7	12 7	18 000
16 0	13 3	8 0	106 364 8	14 0	70 0	12 7	18 000
19 0	15 0	9 5	106 366 8	17 0	66 7	12 7	18 000
25 4	17 0	12 7	106 368 8	23 8	73 0	12 7	18 000

Spare Parts

			
6 35	310 650 1	193 400 0	194 111 0
		3 4	9
8 0	310 650 2	193 400 0	194 111 0
	3 4	7 9	
9 5	310 650 3	193 400 0	194 111 0
	3 4	9	
12 7	310 650 4	193 148 2	194 101 5
	4 5 6	15	

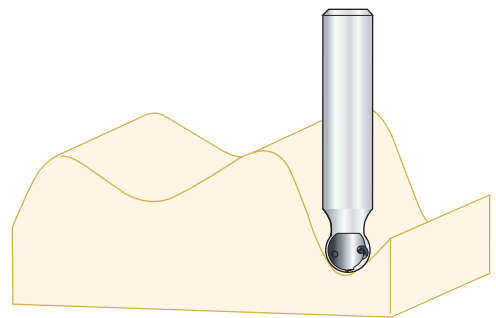
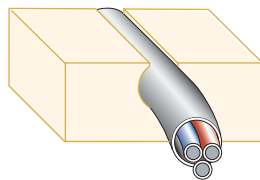

IT/106 362 9



IT/106 364 9

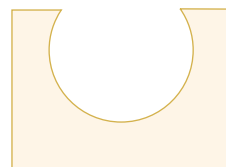

IT/106 366 9

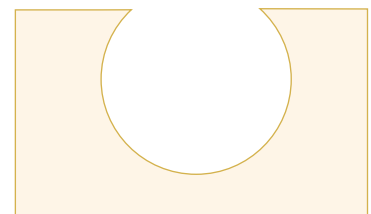

IT/106 368 9



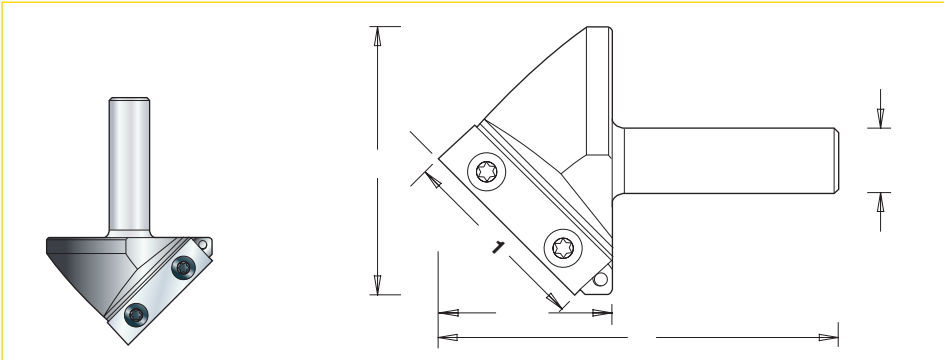

Disposable Insert V Groove Router Cutter

Disposable insert V groover router cutter complete with one or two cutting flutes. Suitable for producing chamfer cuts or engraving in softwood, hardwood and man-made boards. For use on routers and light machining centres with or without CNC control.



1								
20 8	556 287 8	45	25 0	27 0	60 3	1	12 7	18 000
22 8	105 352 8	50	24 5	27 0	65	1	12 7	18 000
26 0	556 635 8	60	23 4	27 0	60 4	1	12 7	18 000
31 0	105 356 8	70	22 1	27 0	66	1	12 7	18 000
38 4	105 360 8	90	19 0	27 0	76 5	1	12 7	18 000
41 2	105 362 8	100	17 3	27 0	81	1	12 7	18 000
44 2	105 364 8	110	15 5	27 0	81	1	12 7	18 000
51 6	105 400 8	120	14 7	29 8	77 7	2	12 7	18 000
54 0	105 366 8	130	12 7	29 8	77 0	2	12 7	18 000
57 6	105 390 8	150	7 6	29 5	75 0	2	12 7	18 000
58 7	105 368 8	160	5 0	29 8	70 7	2	12 7	18 000

Spare Parts

			
45	310 523 0 27 9 1 5	193 354 8 3 5 4 8	194 101 5 15
50	310 523 0 27 9 1 5	193 354 8 3 5 4 8	
60	310 523 0 27 9 1 5	193 354 8 3 5 4 8	
70	310 523 0 27 9 1 5	193 354 8 3 5 4 8	
90	310 500 3 28 12 1 5	193 354 8 3 5 4 8	
100	310 500 3 28 12 1 5	193 354 8 3 5 4 8	
110	310 500 3 28 12 1 5	193 354 8 3 5 4 8	
120	310 500 6 29 8 12 1 5	193 148 1 4 5 6	
130	310 500 6 29 8 12 1 5	193 148 1 4 5 6	
150	310 500 6 29 8 12 1 5	193 148 2 4 5 6	
160	310 500 6 29 8 12 1 5	193 148 2 4 5 6	

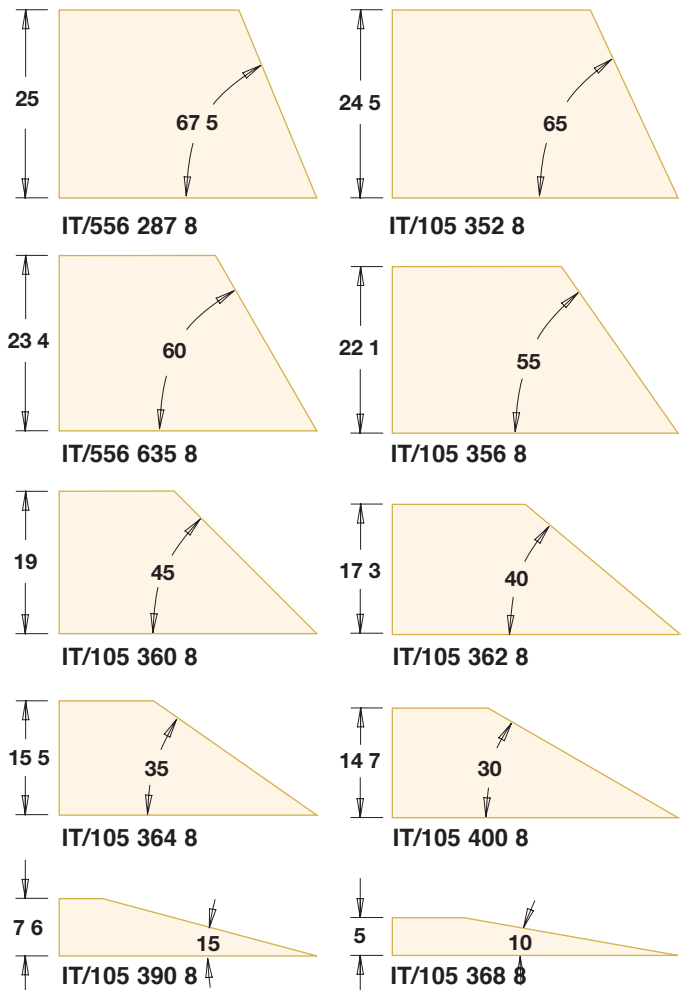



Disposable Insert Raised Panel Router Cutter

Disposable insert raised panel router cutter complete with two cutting flutes. Suitable for producing raised panel profiles in softwood, hardwood and man-made boards. For use on routers and light machining centres with or without CNC control. Please note: Cutter can be ordered with or without the under cutter. Tool without under cutter comes complete with ball bearing set and anti-dust plug.

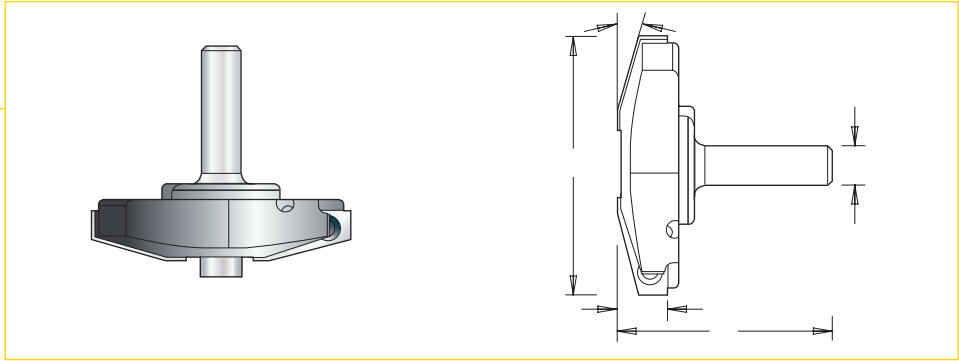

85 8	25	822 301 8	20 2	71	12 7	12 000
------	----	-----------	------	----	------	--------

- ⚠ Cutter can also be supplied complete with under cutter fitted Order Ref. IT/8223058.
- ⚠ Remove bearing for CNC work.

Spare Parts

312 200 1	193 148 2	194 101 5	822 501 0	312 200 3	190 870 0	193 400 0	194 110 0	
31 17 2	4 5 6	15	54 26 7 1 2	13 9 9 5 2 8	12 7 4 7 5 6	3 4	9	

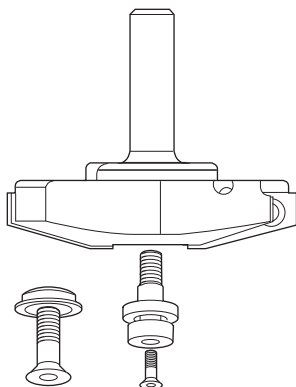
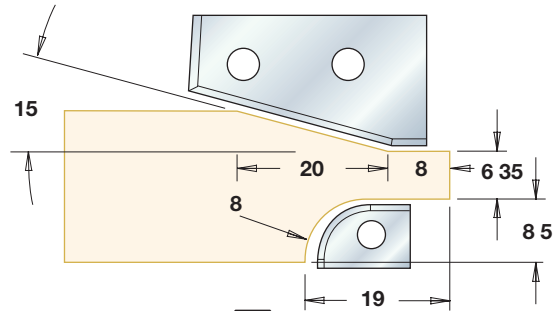
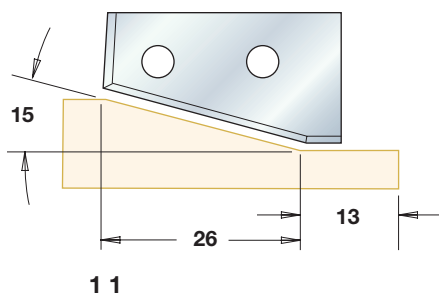

IT/822 301 8

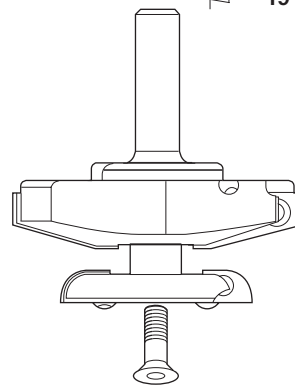

IT/822 305 8



Disposable Insert Raised Panel Router Cutter

Disposable insert raised panel router cutter complete with two cutting flutes. Suitable for producing raised panel profiles in softwood, hardwood and man-made boards. For use on routers and light machining centres with or without CNC control.

Please note: Cutter can be ordered with or without the under cutter. Tool without under cutter comes complete with ball bearing set and anti-dust plug.

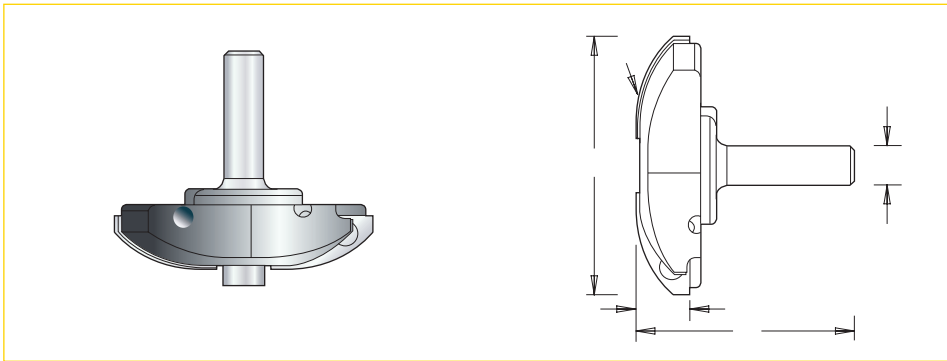

85 8 40 822 302 8 21 2 72 12 7 12 000

- ⚠ Cutter can also be supplied complete with under cutter fitted Order Ref. IT/8223108.
- ⚠ Remove bearing for CNC work.

Spare Parts

312 200 2	193 148 2	194 101 5	822 501 0	312 200 3	190 870 0	193 400 0	194 110 0	
33 3 18 5 2	4 6	15	54 26 7 1 2	139 9 5 3 8	127 4 7 5 6	3 4	9	

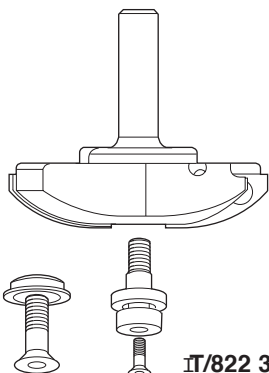
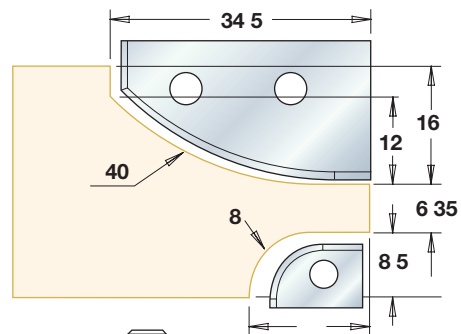
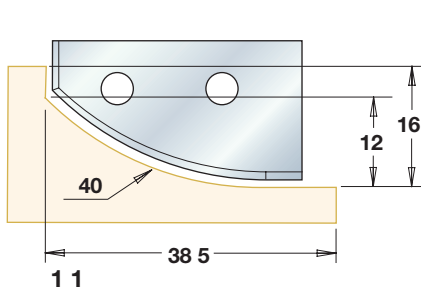

IT/822 302 8

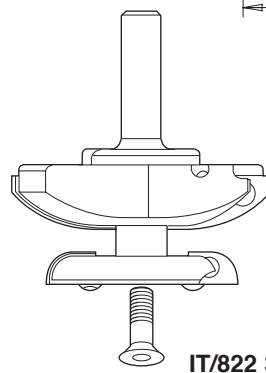

IT/822 310 8



Disposable Insert Raised Panel Router Cutter

Disposable insert raised panel router cutter complete with two cutting flutes. Suitable for producing raised panel profiles in softwood, hardwood and man-made boards. For use on routers and light machining centres with or without CNC control. Please note: Cutter can be ordered with or without the under cutter. Tool without under cutter comes complete with ball bearing set and anti-dust plug.

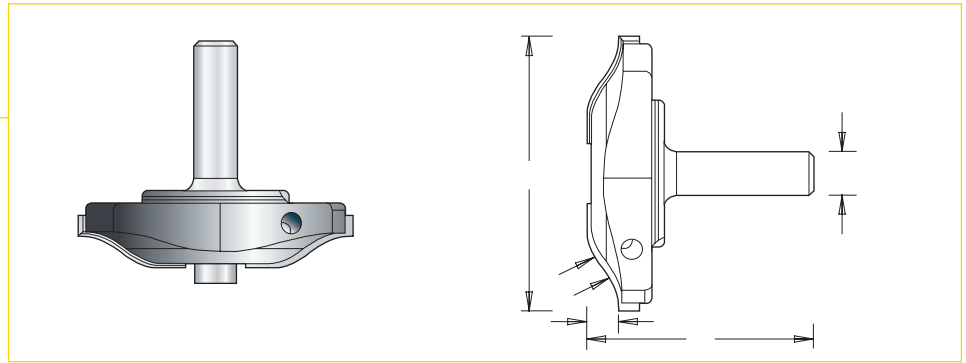

85 7	22	822 320 8	19 2	69	12 7	12 000
------	----	-----------	------	----	------	--------

- ⚠ Cutter can also be supplied complete with under cutter fitted Order Ref. IT/8223258.
- ⚠ Remove bearing for CNC work.

Spare Parts

312 200 5	193 395 0	194 101 5	822 501 0	312 200 3	190 870 0	193 400 0	194 110 0	
32 20 15	4 5 6	15	54 26 7 1 2	13 9 9 5 2	12 7 4 7 5 6	3 4	9	

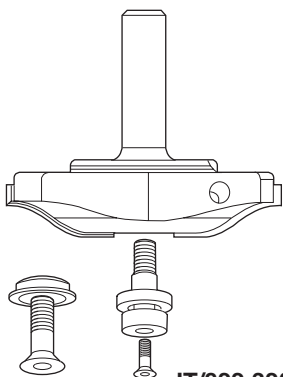
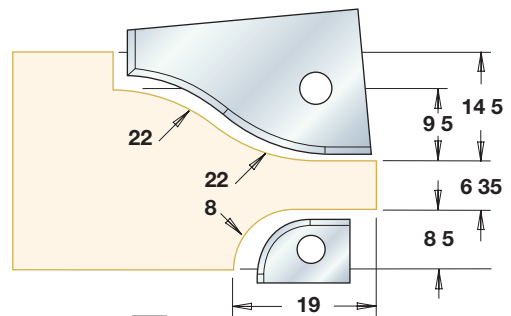
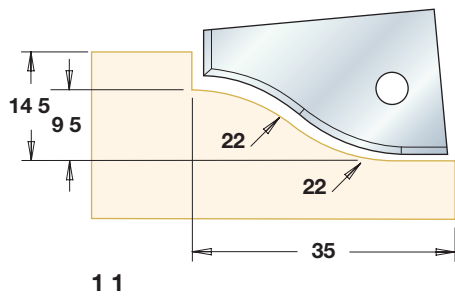

IT/822 320 8

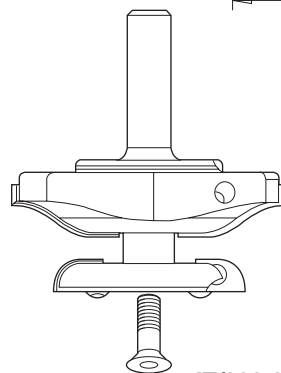

IT/822 325 8



Disposable Insert Tongue & Groove Router Cutter

Disposable insert tongue & groove router cutter complete with two cutting flutes. Suitable for producing tongue & groove panels in softwood, hardwood and man-made boards. For use on routers and light machining centres with or without CNC control. Cutter includes a fine adjusting option to give the perfect fit.

1								
1	60	30	5 4 6 0	845 021 8	9 5	75	1 2	18 000
2	60	30	6 1 6 6	845 116 8	9 5	75	1 2	18 000

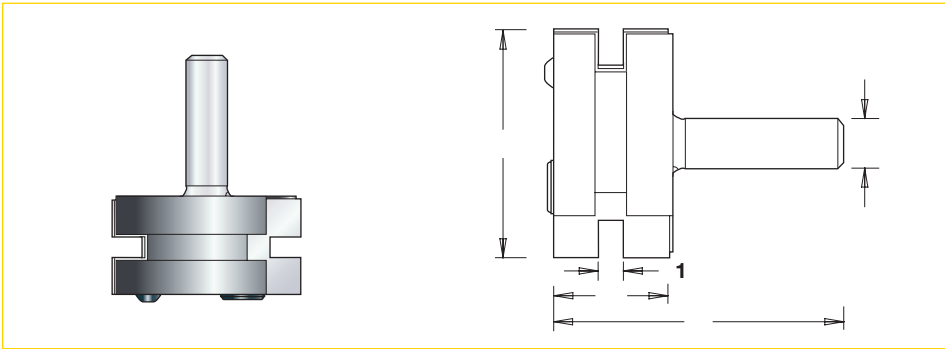



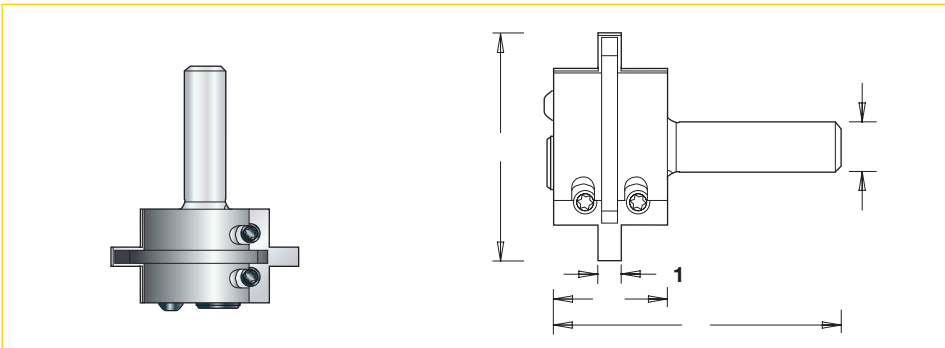



1			5					
60	30	5 4 6 0	845 019 8	9 5	75	1 2	18 000	
60	30	6 1 6 6	845 006 8	9 5	75	1 2	18 000	



1								
60	30	5 4 6 0	845 020 8	9 5	75	1 2	18 000	
60	30	6 1 6 6	845 016 8	9 5	75	1 2	18 000	

Spare Parts

1							
5 4 6 0	314 500 5	314 501 5	193 364 8	193 148 1	193 072 0	194 020 0	194 101 5
	30 22 2	30 22 2	3 5 4 8	4 5 6	6 12 5	2	15
6 1 6 6	314 501 8	314 501 9					
	30 22 2	30 22 2					

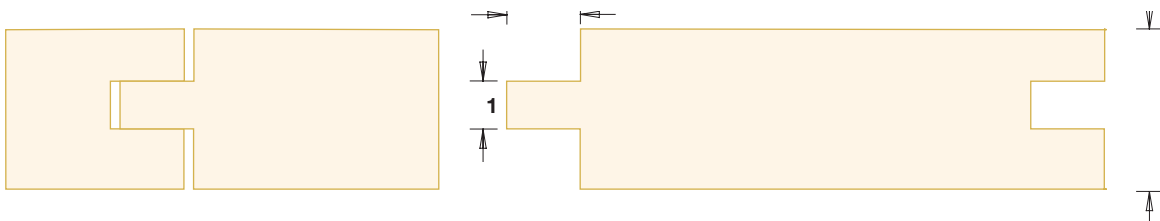



Disposable Insert Profile Scribing Router Cutter



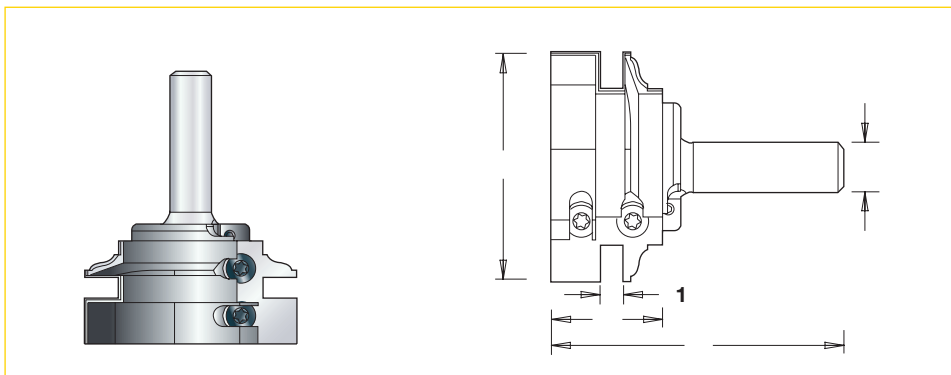
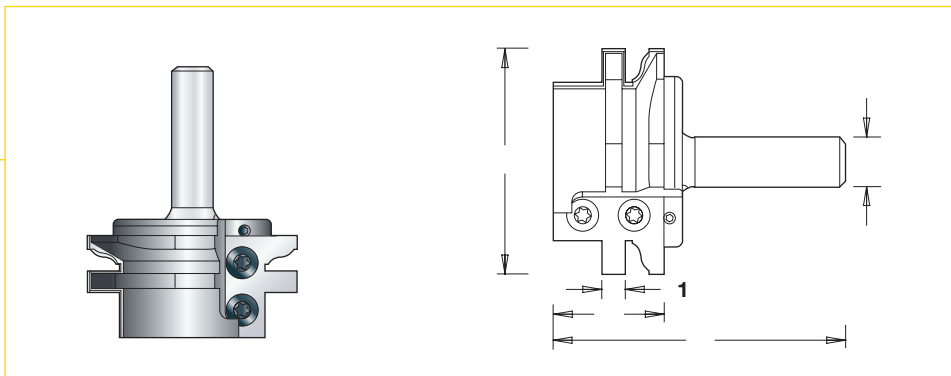

Disposable insert profile scribing router cutter complete with two cutting flutes. Suitable for producing profiles and scribes in softwood, hardwood and man-made boards. For use on routers and light machining centres with or without CNC control. No adjustment required. Maximum wood thickness 30mm.



1

1							
62	30	6 35	845 114 8	9 5	75	1 2	18 000
62	30	6 35	845 014 8	9 5	75	1 2	18 000
62	30	6 35	845 004 8	9 5	75	1 2	18 000

Spare Parts

				
Desc.	T.C. Blade A	T.C. Blade B	Torx® Screw	Torx Key®
Prod. Ref.	314 501 4	314 500 4	193 395 0	194 101 5
Size	30 23 2	30 23 2	4 6	15

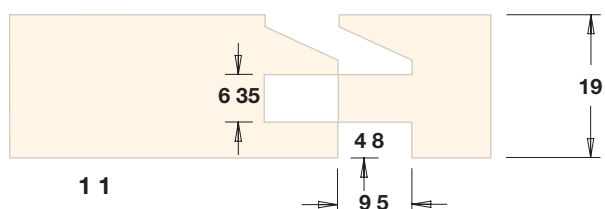



Disposable Insert Profile Scribing Router Cutter (Continued)

Disposable insert profile scribing router cutter complete with two cutting flutes. Suitable for producing profiles and scribes in softwood, hardwood and man-made boards. For use on routers and light machining centres with or without CNC control. No adjustment required. Maximum wood thickness 30mm.

2

1							
62	30	6 35	845 113 8	9 5	75	1 2	18 000
62	30	6 35	845 013 8	9 5	75	1 2	18 000
62	30	6 35	845 003 8	9 5	75	1 2	18 000

Spare Parts

Desc.	T.C. Blade A	T.C. Blade B	Torx® Screw	Torx Key®
Prod. Ref.	314 501 3	314 500 3	193 395 0	194 101 5
Size	30 23 2	30 23 2	4 6	15

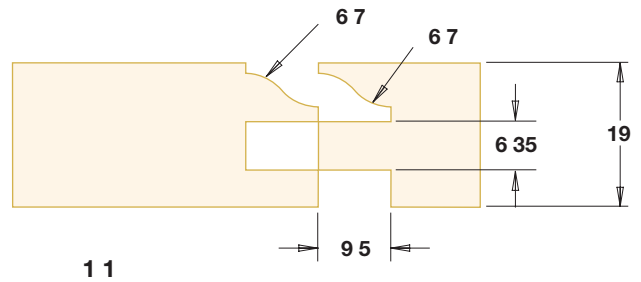

3

1							
62	30	6 35	845 111 8	9 5	75	1 2	18 000
62	30	6 35	845 011 8	9 5	75	1 2	18 000
62	30	6 35	845 001 8	9 5	75	1 2	18 000

Spare Parts

Desc.	T.C. Blade A	T.C. Blade B	Torx® Screw	Torx Key®
Prod. Ref.	314 501 1	314 500 1	193 395 0	194 101 5
Size	30 23 2	30 23 2	4 6	15

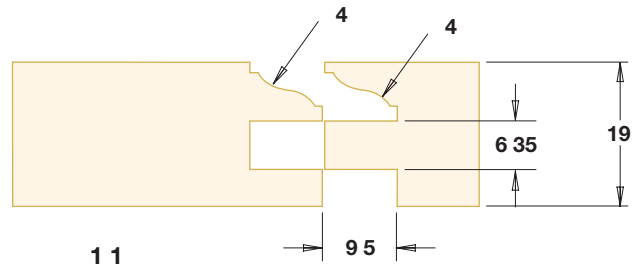

4

1							
62	30	6 35	845 112 8	9 5	75	1 2	18 000
62	30	6 35	845 012 8	9 5	75	1 2	18 000
62	30	6 35	845 002 8	9 5	75	1 2	18 000

Spare Parts

Desc.	T.C. Blade A	T.C. Blade B	Torx® Screw	Torx Key®
Prod. Ref.	314 501 2	314 500 2	193 395 0	194 101 5
Size	30 23 2	30 23 2	4 6	15

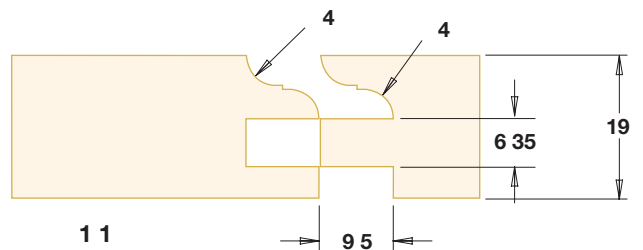



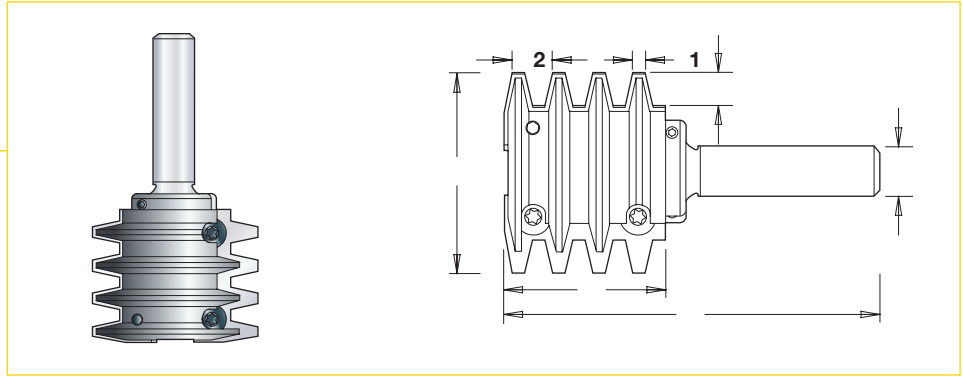

Disposable Insert Finger Joint Router Cutter

Disposable insert Finger Joint router cutter complete with two cutting flutes. Suitable for producing finger joints in softwood, hardwood and man-made boards. For use on routers and light machining centres with or without CNC control. Cutter will produce the best fitting results without any adjustment required.



			1	2				
50	40	841 001 8	3 2	10 0	8	93 5	1 2	18 000

Spare Parts

			
Desc.	T.C. Blade	Torx® Screw	Torx Key®
Prod. Ref.	314 900 1	193 395 0	194 101 5
Size	40 19 2	4 6	15

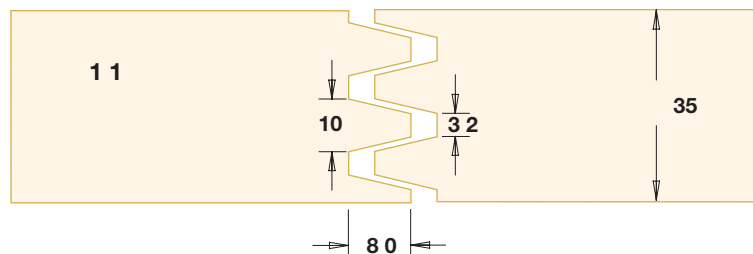
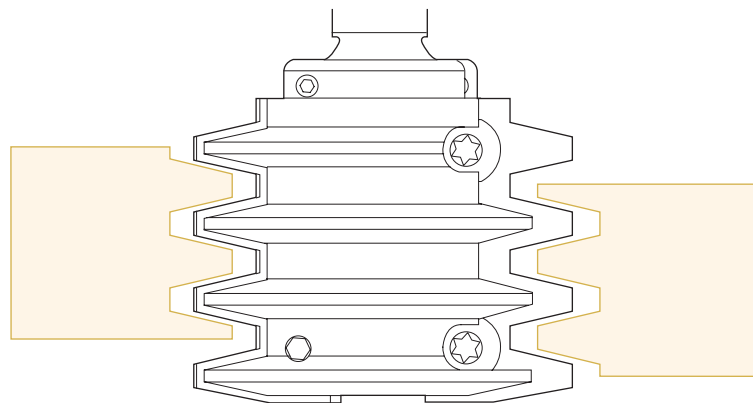

**Available
throughout the UK**

Phone 0800 467363 for your free 2008/9 Routing and Industrial
Tooling Catalogues and details of your nearest stockist.



Your CNC SMART supplier

Fax _____ 01923 228657
Email _____ tiggj@trendm.co.uk
Web _____ www.trend-uk.com

Trend Machinery & Cutting Tools Ltd.
Odhams Trading Estate St. Albans Road
Watford WD24 7TR England.

© All trademarks acknowledged.

