

## Parts Information: Hydraulic Press Premier 50tonne Floor Type with Foot Pedal Model No: YK50FFPV2

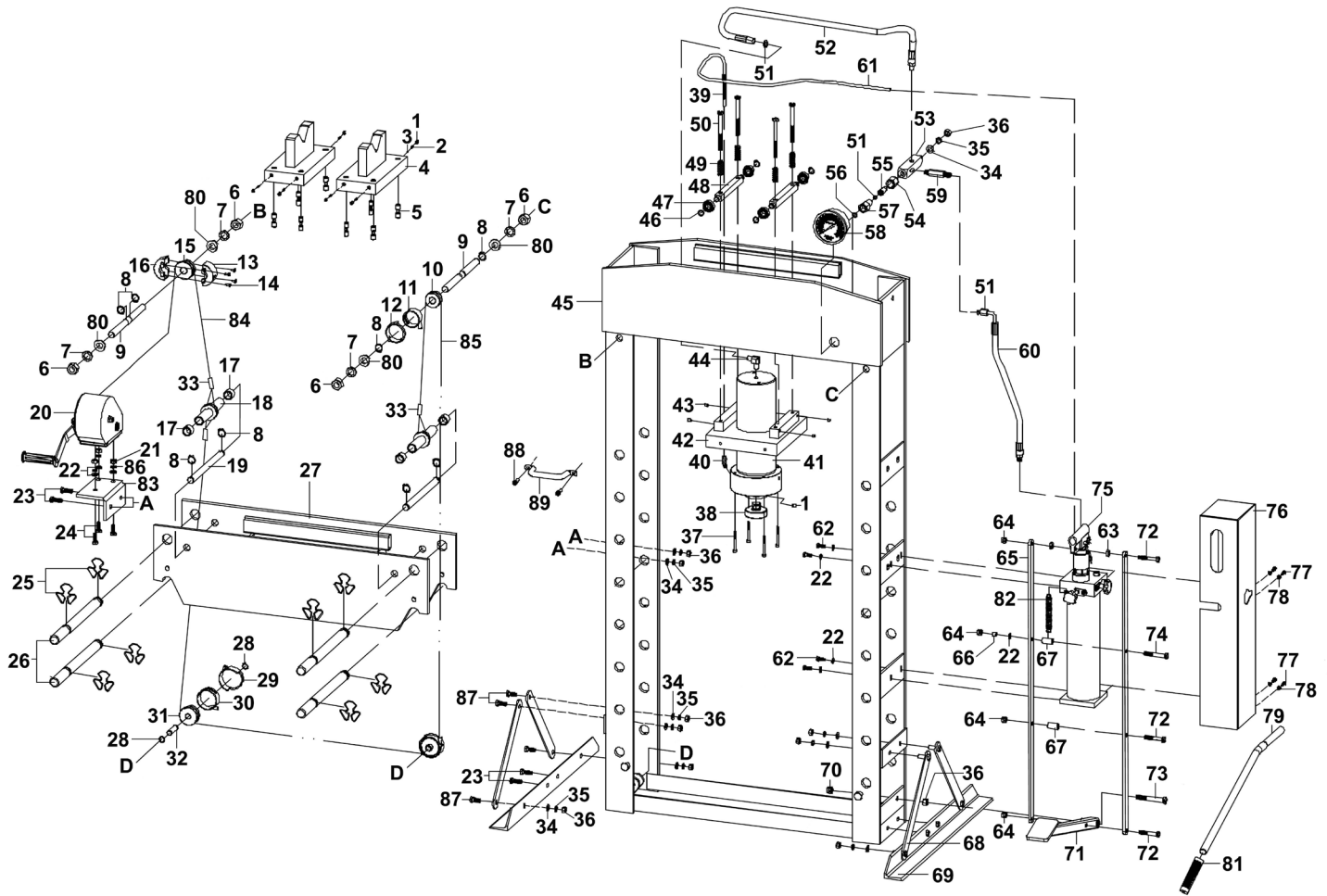

Item	Part No.	Description
1	GSM810.S	Grub Screw M8x10 (Single)
2	YK50FFPV2-02	Spring Dia 4.8mm
3	SB-5.6	Steel Ball 5.6mm
4	YK50FFPV2-04	V-Block
5	YK50FFPV2-05	Screw
6	YK50FFPV2-06	Nut
7	YK50FFPV2-07	Lock Washer
8	YK50FFPV2-08	Ext Circlip For Pin
9	YK50FFPV2-09	Pin For Roller
10	YK50FFPV2-10	Roller
11	YK50FFPV2-11	Protective Housing (No.3)

Item	Part No.	Description
12	YK50FFPV2-12	Protective Housing (D)
13	YK50FFPV2-13	Protective Housing (A)
14	YK50FFPV2-14	Screw
15	YK50FFPV2-15	Roller ©
16	YK50FFPV2-16	Protective Housing (B)
17	YK50FFPV2-17	Bush
18	YK50FFPV2-18	Shaft Wheel Ass'y
19	YK50FFPV2-19	Pin
20	YK50FFPV2-20	Hand Winch
21	SN10.S	Steel Nut M10 Zinc

**NOTE:** It is our policy to continually improve products and as such we reserve the right to alter data, specifications and component parts without prior notice. There may be alternative versions of this product, please contact us should you require this information.

**IMPORTANT:** No liability is accepted for incorrect use of product. Spare parts must be fitted by a competent person

**WARRANTY:** Guarantee is 12 months from purchase date, proof of which will be required for any claim.



Parts Information:  
**Hydraulic Press Premier 50tonne Floor  
Type with Foot Pedal  
Model No: YK50FFPV2**

Item	Part No.	Description
22	FWM10.S	Flat Washer M10 Zinc
23	YK50FFPV2-23	Bolt
24	SS1025.S	Hex Head Set Screw M10 X 25 Zinc
25	YK50FFPV2-25	Retaining Clip
26	YK50FFPV2-26	Pin, Table Support 400x30mm
27	YK50FFPV2-27	Bed Frame
28	YK50FFPV2-28	Ring
29	YK50FFPV2-29	Protective Housing (B)
30	YK50FFPV2-30	Protective Housing (A)
31	YK50FFPV2-31	Large Roller
32	YK50FFPV2-32	Roller
33	YK50FFPV2-33	Cable Protection
34	FWM12.S	Flat Washer M12 Zinc
35	SWM12.S	Spring Washer M12 Zinc
36	SN12.S	Steel Nut M12 Zinc
37	YK50FFPV2-37	Screw
38	YK50FFPV2-38	Serrated Saddle
39	YK50FFPV2-39	Spring
40	YK50FFPV2-40	Air Hose Connection
41	YK50FFPV2-41	Ram
42	YK50FFPV2-42	Ram Plate
43	YK50FFPV2-43	Screw
44	YK50FFPV2-44	Elbow Fitting
45	YK50FFPV2-45	Frame
46	YK50FFPV2-46	Retaining Ring
47	B/6202ZZ	Bearing 6202zz
48	YK50FFPV2-48	Connecting Plate
49	YK50FFPV2-49	Spring Dia 16.45mm
50	HHB10120.S	Hex Head Bolt M10 x 120mm
51	SA802.23	O-ring, (Ex: 9.63 In: 6.07 Cs: 1.78)
52	YK50FFPV2-52	Oil Hose (Ram) 20mm X 1240mm
53	YK50FFPV2-53	Union Seat
54	YK50FFPV2-54	Union Nut
55	YK50FFPV2-55	Union Screw

Item	Part No.	Description
56	YK50FFPV2-56	Nylon Ring
57	YK50FFPV2-57	Gauge Fitting
58	YK50FFPV2-58	Pressure Gauge
59	YK50FFPV2-59	Joint
60	YK50FFPV2-60	Oil Hose(Pump)20mm x 760mm
61	YK50FFPV2-61	Air Hose
62	YK50FFPV2-62	Bolt
63	YK50FFPV2-63	Bushing
64	NLN10.S	Nyloc Nut M10 Zinc
65	YK50FFPV2-65	Support
66	YK50FFPV2-66	Bushing
67	YK50FFPV2-67	Bushing
68	YK50FFPV2-68	Support
69	YK50FFPV2-69	Base Section
70	YK50FFPV2-70	Nut
71	YK50FFPV2-71	Foot Pedal
72	SS1055.S	Hex Head Set Screw M10 X 55 Zinc
73	YK50FFPV2-73	Bolt
74	YK50FFPV2-74	Bolt
75	YK50FFPV2-75	Pump
76	YK50FFPV2-76	Protective Housing For Pump
77	YK50FFPV2-77	Screw
78	YK50FFPV2-78	Flat Washer
79	YK50FFPV2-79	Handle
80	YK50FFPV2-80	Flat Washer
81	YK50FFPV2-81	Handle Grip
82	YK50FFPV2-82	Spring Dia 22.6mm
83	YK50FFPV2-83	Plate For Handwinch
84	YK50FFPV2-84	Steel Cable
85	YK50FFPV2-85	Steel Cable
86	SWM10.S	Spring Washer M10 Zinc
87	SS1230.S	Hex Head Set Screw M12 X 30 Zinc
88	YK50FFPV2-88	Screw For Handle
89	YK50FFPV2-89	Handle For Ram Plate

**NOTE:** It is our policy to continually improve products and as such we reserve the right to alter data, specifications and component parts without prior notice. There may be alternative versions of this product, please contact us should you require this information.

**IMPORTANT:** No liability is accepted for incorrect use of product. Spare parts must be fitted by a competent person

**WARRANTY:** Guarantee is 12 months from purchase date, proof of which will be required for any claim.

**Sealey Group**, Kempson Way, Suffolk Business Park, Bury St Edmunds, Suffolk. IP32 7AR



01284 757500



01284 703534



sales@sealey.co.uk



www.sealey.co.uk