

Item	Part No.	Description
1	YK30XF.01	V-Block
2	YK30XF.02	Bed, Frame
3	YK759FAH.13	Retaining Clip
4	YK30XF.04	Pin, Table Support 420x30mm
5	YK30XF.05	Frame Support
6	YK30XF.06	Washer
7	YK30XF.07	Lock Washer
8	YK30XF.08	Nut
9	YK30XF.09	Base Section

Item	Part No.	Description
10	YK30XF.10	Bolt
11	YK30XF.11	Upright
12	YK30XF.12	Bolt
13	YK30XF.13	Lower Cross Member
14	YK30XF.14	Screw
15	YK30XF.15	Ram Ass'y
16	YK30XF.16	Ram Support Plate
17	YK30XF.17	Screw
18	YK30XF.18	Gauge Connection Nut

**NOTE:** It is our policy to continually improve products and as such we reserve the right to alter data, specifications and component parts without prior notice. There may be alternative versions of this product, please contact us should you require this information.

**IMPORTANT:** No liability is accepted for incorrect use of product. Spare parts must be fitted by a competent person

**WARRANTY:** Guarantee is 12 months from purchase date, proof of which will be required for any claim.



Parts Information:  
**Hydraulic Press 30tonne Floor Type**  
**Model No: YK30XF**

Item	Part No.	Description
19	YK30XF.19	Bolt
20	YK30XF.20	Upper Cross Beam
21	YK30XF.21	Washer
22	YK30XF.22	Lock Washer
23	YK30XF.23	Nut
24	YK30XF.24	Sliding Block
25	YK30XF.25	R-Pin
26	YK30XF.26	Connecting Rod
27	YK30XF.27	Spring
28	YK30XF.28	Bolt
29	YK30XF.29	Retaining Nut For Gauge Adaptor

Item	Part No.	Description
30	YK30XF.30	Gauge Fitting
31	YK759FAH.61	Nylon Ring
32	YK30XF.32	Pressure Gauge (30 Tonne)
33	YK30XF.33	Retaining Nut For Hose Adaptor
34	YK30XF.34	Coupler Ass'y
35	YK20FAH.52	Hydraulic Hose
36	YK30XF.36	Pump Ass'y
37	YK30XF.37	Bolt
38	YK30XF.38	Washer
39	YK30XF.39	Pump Handle
40	YK30XF.40	Pump Handle Grip

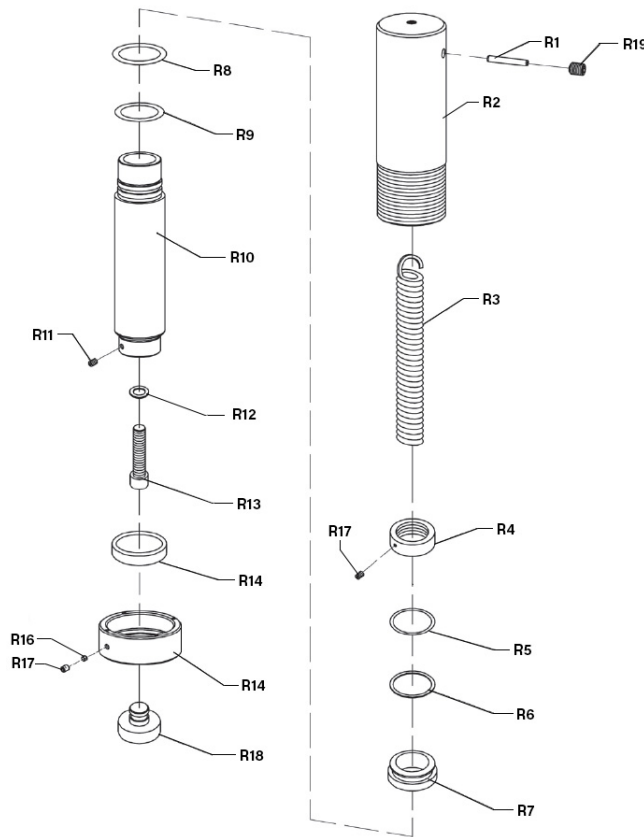

Item	Part No.	Description
R01	YK30XF.R01	Pin
R02	YK30XF.R02	Cylinder Assy
R03	YK30XF.R03	Spring
R04	YK30XF.R04	Nut For Ram
R05	YK30XF.R05	O-Ring, (Ex: 83.05 In: 72.39 Cs: 5.33)
R06	YK30XF.R06	Washer (Ptfе)
R07	YK30XF.R07	Piston
R08	YK30XF.R08	O-Ring, (Ex: 63.80 In: 56.74 Cs: 3.53)
R09	YK30XF.R09	Ring (Ptfе)

Item	Part No.	Description
R10	YK30XF.R10	Piston Rod
R11	YK30XF.R11	Screw
R12	YK30XF.R12	Copper Washer
R13	YK30XF.R13	Screw
R14	YK30XF.R14	Retaining Ring
R15	YK30XF.R15	Cap
R16	YK30XF.R16	Nylon Block
R17	YK30XF.R17	Screw
R18	YK30XF.R18	Saddle, Serrated (M) Ø 58mm (Shaft Ø 25mm)

**NOTE:** It is our policy to continually improve products and as such we reserve the right to alter data, specifications and component parts without prior notice. There may be alternative versions of this product, please contact us should you require this information.

**IMPORTANT:** No liability is accepted for incorrect use of product. Spare parts must be fitted by a competent person

**WARRANTY:** Guarantee is 12 months from purchase date, proof of which will be required for any claim.

Sealey Group, Kempson Way, Suffolk Business Park, Bury St Edmunds, Suffolk. IP32 7AR



01284 757500



sales@sealey.co.uk



www.sealey.co.uk

Item	Part No.	Description
P01	YK30XF.P01	Screw
P02	YK30XF.P02	Reservoir
P03	YK30XF.P03	Steel Ball
P04	YK30XF.P04	Spring Conical
P05	YK30XF.P05	Copper Washer
P06	YK30XF.P06	Screw
P07	YK30XF.P07	Steel Ball
P08	YK30XF.P08	Ball Seat
P09	YK30XF.P09	Spring Dia 7.8mm
P10	YK30XF.P10	Screw
P11	YK30XF.P11	O-Ring, (Ex: 12 In: 8.17 Cs: 2.42)
P12	YK30XF.P12	Screw
P13	YK30XF.P13	Dust Cap
P14	YK30XF.P14	Steel Ball
P15	YK30XF.P15	Ball Seat
P16	YK30XF.P16	Spring Dia 7.5mm
P17	YK30XF.P17	Copper Washer
P18	YK30XF.P18	Release Valve Seat
P19	YK30XF.P19	Release Valve
P20	YK30XF.P20	U-Ring
P21	YK30XF.P21	Lock Washer
P22	BHSS610.SB	Button Head Socket Screw M6 X 10 Black
P23	YK30XF.P23	Spring Conical
P24	YK30XF.P24	O-Ring, (Ex: 39.71 In: 33.85 Cs: 2.93)
P25	YK30XF.P25	Copper Washer
P26	YK30XF.P26	Pump Core
P27	YK30XF.P27	Seal 28*35.5*5
P28	YK30XF.P28	O-Ring, (Ex: 28.88 In: 21.82 Cs: 3.53)
P29	YK30XF.P29	Washer (Ptfе)
P30	YK30XF.P30	Pump Core
P31	YK30XF.P31	Retaining Ring
P32	YK30XF.P32	Pump Core
P33	YK30XF.P33	Cotter Pin 1.9 x 18.
P34	YK30XF.P34	Cotter Pin 1.8 x 25
P35	YK30XF.P35	Ring For Ram
P36	YK30XF.P36	Connecting Rod
P37	YK30XF.P37	O-Ring, (Ex: 12.83 In: 7.59 Cs: 2.62)

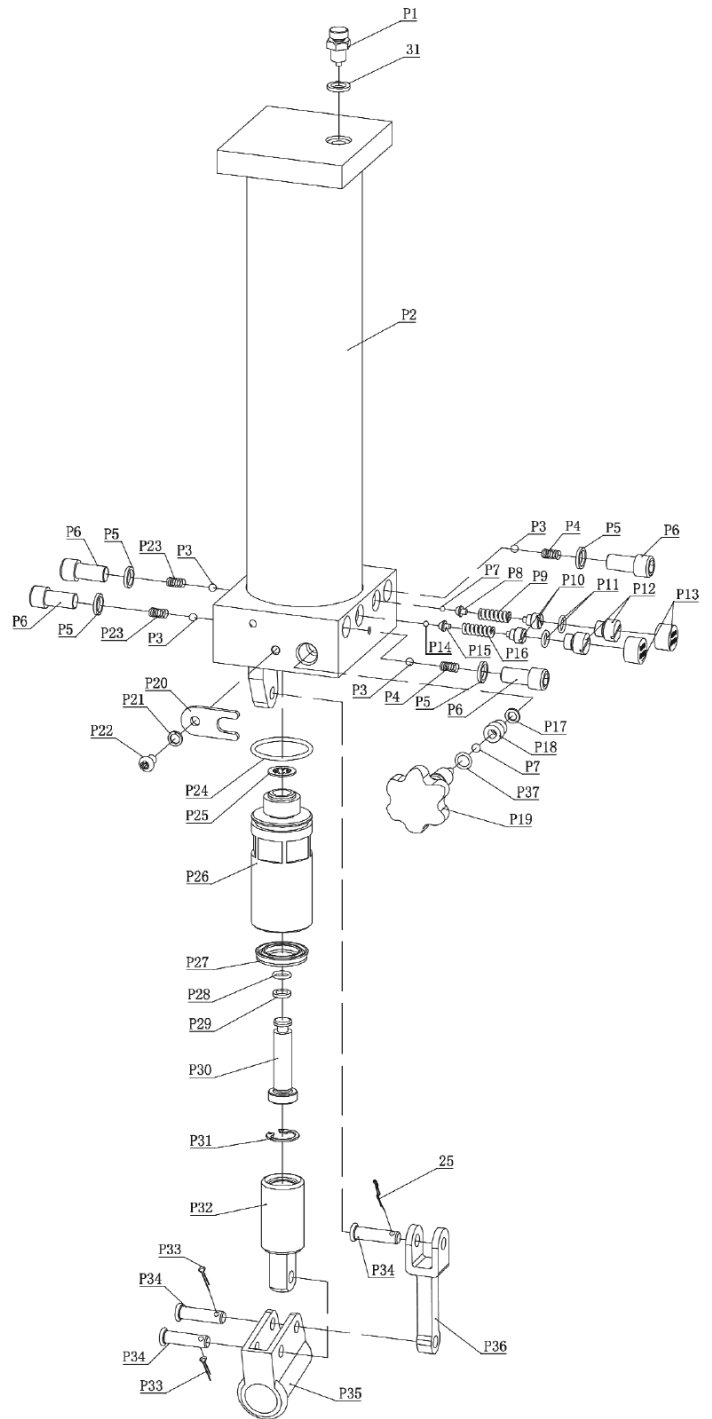

**NOTE:** It is our policy to continually improve products and as such we reserve the right to alter data, specifications and component parts without prior notice. There may be alternative versions of this product, please contact us should you require this information.

**IMPORTANT:** No liability is accepted for incorrect use of product. Spare parts must be fitted by a competent person

**WARRANTY:** Guarantee is 12 months from purchase date, proof of which will be required for any claim.