

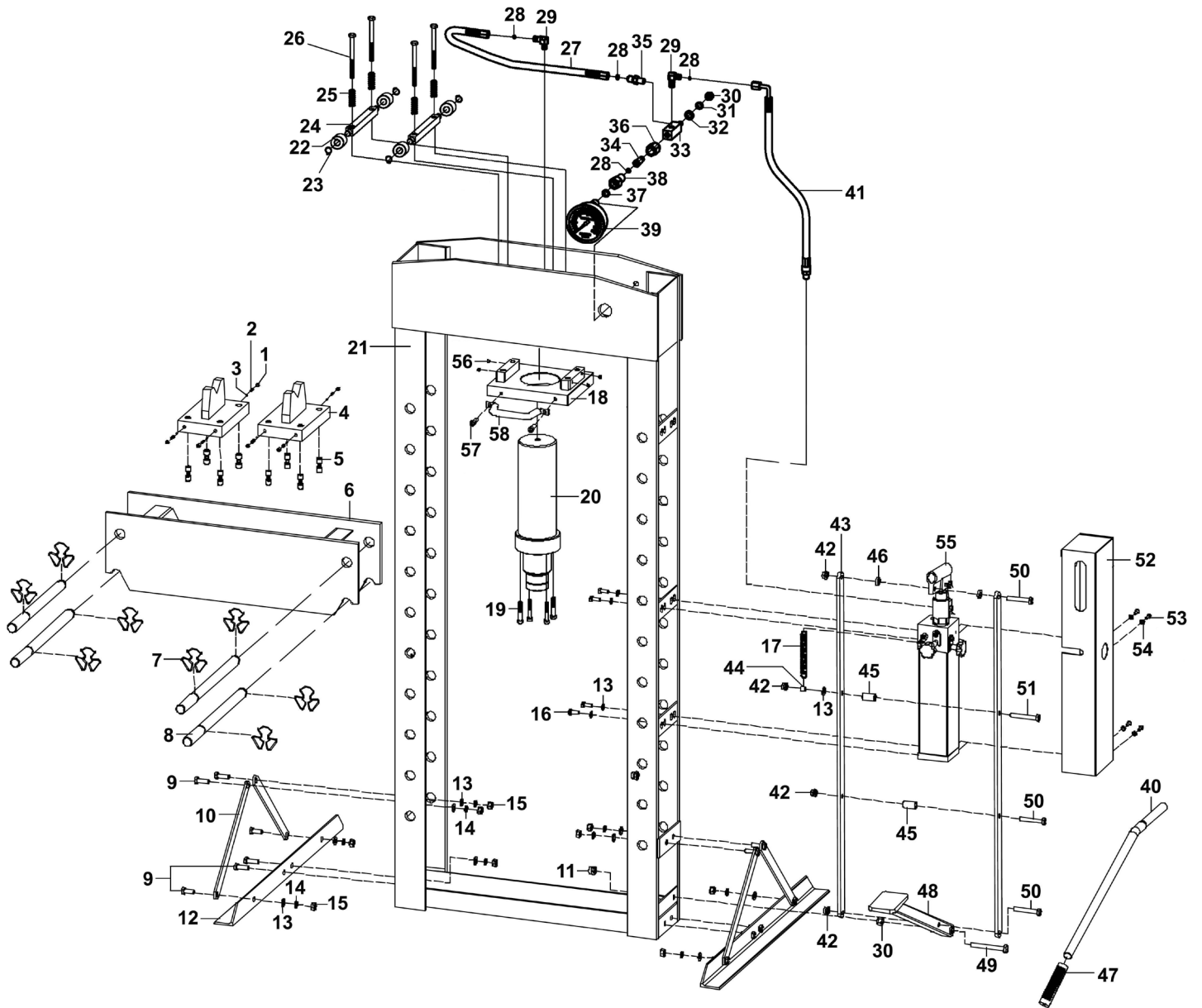

Parts Information:  
Hydraulic Press Premier 20tonne Floor  
Type with Foot Pedal  
Model No: YK30FFP.V2



**NOTE:** It is our policy to continually improve products and as such we reserve the right to alter data, specifications and component parts without prior notice. There may be alternative versions of this product, please contact us should you require this information.

**IMPORTANT:** No liability is accepted for incorrect use of product. Spare parts must be fitted by a competent person

**WARRANTY:** Guarantee is 12 months from purchase date, proof of which will be required for any claim.

Sealey Group, Kempson Way, Suffolk Business Park, Bury St Edmunds, Suffolk. IP32 7AR



01284 757500



01284 703534



sales@sealey.co.uk



www.sealey.co.uk



Parts Information:  
**Hydraulic Press Premier 20tonne Floor  
Type with Foot Pedal  
Model No: YK30FFPV2**

Item	Part No.	Description
1	GSM810.S	Grub Screw M8x10 (Single)
2	YK30FFPV2-02	Spring Dia 4.8mm
3	SB-5.6	Steel Ball 5.6mm
4	YK30FFPV2-04	V-Block
5	YK30FFPV2-05	Screw
6	YK30FFPV2-06	Bed Frame
7	YK30FFPV2-07	Retaining Clip
8	YK30FFPV2-08	Pin, Table Support 300x25mm
9	YK30FFPV2-09	Screw
10	YK30FFPV2-10	Support
11	YK30FFPV2-11	Nut
12	YK30FFPV2-12	Base Section
13	YK30FFPV2-13	Washer
14	YK30FFPV2-14	Lock Washer
15	YK30FFPV2-15	Nut
16	YK30FFPV2-16	Screw
17	YK30FFPV2-17	Spring For Pump
18	YK30FFPV2-18	Ram Plate
19	YK30FFPV2-19	Bolt For Ram
20	YK30FFPV2-20	Ram
21	YK30FFPV2-21	Frame
22	YK30FFPV2-22	Slide Block
23	YK30FFPV2-23	Retaining Ring
24	YK30FFPV2-24	Connecting Plate
25	YK30FFPV2-25	Spring Dia 16.45mm
26	HHB10120.S	Hex Head Bolt M10 x 120mm
27	YK30FFPV2-27	Oil Hose (Ram) 20mm x 860mm
28	SA802.23	O-ring, (Ex: 9.63 In: 6.07 Cs: 1.78)
29	YK30FFPV2-29	Elbow Fitting

Item	Part No.	Description
30	YK30FFPV2-30	Nut
31	YK30FFPV2-31	Lock Washer
32	YK30FFPV2-32	Washer
33	YK30FFPV2-33	Union Seat
34	YK30FFPV2-34	Union Screw
35	YK30FFPV2-35	Joint
36	YK30FFPV2-36	Union Nut
37	YK30FFPV2-37	Nylon Ring
38	YK30FFPV2-38	Gauge Fitting
39	YK30FFPV2-39	Pressure Gauge
40	YK30FFPV2-40	Handle
41	YK30FFPV2-41	Oil Hose (Pump) 20mm x 820mm
42	YK30FFPV2-42	Nut
43	YK30FFPV2-43	Support
44	YK30FFPV2-44	Bushing
45	YK30FFPV2-45	Bushing
46	YK30FFPV2-46	Bushing
47	YK30FFPV2-47	Handle Grip
48	YK30FFPV2-48	Foot Pedal
49	YK30FFPV2-49	Screw
50	YK30FFPV2-50	Screw
51	YK30FFPV2-51	Screw
52	YK30FFPV2-52	Protective Housing For Pump
53	YK30FFPV2-53	Screw
54	YK30FFPV2-54	Washer
55	YK30FFPV2-55	Pump
56	YK30FFPV2-56	Screw
57	YK30FFPV2-57	Screw For Handle
58	YK30FFPV2-58	Carry Handle For Ram Plate

**NOTE:** It is our policy to continually improve products and as such we reserve the right to alter data, specifications and component parts without prior notice. There may be alternative versions of this product, please contact us should you require this information.

**IMPORTANT:** No liability is accepted for incorrect use of product. Spare parts must be fitted by a competent person

**WARRANTY:** Guarantee is 12 months from purchase date, proof of which will be required for any claim.

**Sealey Group**, Kempson Way, Suffolk Business Park, Bury St Edmunds, Suffolk. IP32 7AR



01284 757500



01284 703534



sales@sealey.co.uk



www.sealey.co.uk