

Parts Information:
**Air/Hydraulic Press Yankee 20tonne Floor
 Type
 Model No: YK20FAH**

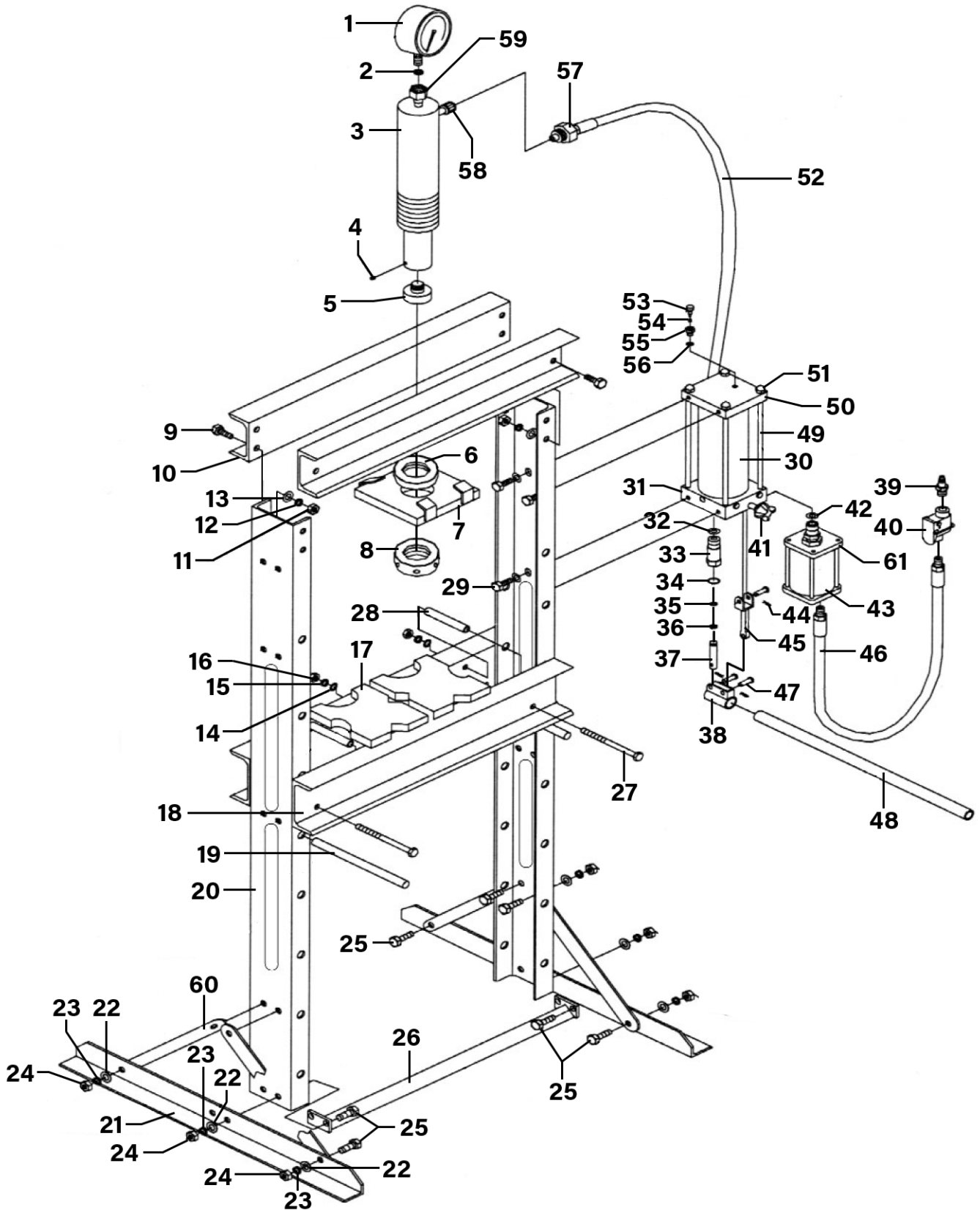

NOTE: It is our policy to continually improve products and as such we reserve the right to alter data, specifications and component parts without prior notice. There may be alternative versions of this product, please contact us should you require this information.

IMPORTANT: No liability is accepted for incorrect use of product. Spare parts must be fitted by a competent person

WARRANTY: Guarantee is 12 months from purchase date, proof of which will be required for any claim.



Parts Information:
**Air/Hydraulic Press Yankee 20tonne Floor
 Type
 Model No: YK20FAH**

Item	Part No.	Description
1	YK20FAH.01	Gauge 1000kgf/cm ² 28t 110mm od Btm Fitting
2	YK759FAH.61	Nylon Ring
3	YK20FAH.RC	Hydraulic Ram Complete.
4	YK20FAH.04	Grub Screw M6x5
5	YK20FAH.05	Saddle, Serrated (M) Ø 48mm (Shaft Ø 25mm)
6	YK20FAH.06	Round Nut, Upper Ring
7	YK20FAH.07	Plate
8	YK20FAH.08	Round Nut, Lower
9	YK20FAH.09	Bolt M16x35
10	YK20FAH.10	Cross Beam, Upper
11	SN16.S	Steel Nut M16 Zinc
12	SWM16.S	Spring Washer M16 Zinc
13	FWM16.S	Flat Washer M16 Zinc
14	FWM10.S	Flat Washer M10 Zinc
15	SWM10.S	Spring Washer M10 Zinc
16	SN10.S	Steel Nut M10 Zinc
17	YK20F.V3-17	V- Block (190x100x30)
18	YK20F.V3-18	Press Bed Frame
19	YK20F.V3-19	Pin, table support 250x25mm
20	YK20FAH.V2-20	Post
21	YK20FAH.21	Base Section
22	FWM12.S	Flat Washer M12 Zinc
23	SWM12.S	Spring Washer M12 Zinc
24	SN12.S	Steel Nut M12 Zinc
25	SS1015.S	Hex Head Set Screw M10 X 15 Zinc
26	YK20FAH.26	Lower Cross Member
27	HHB10130.S	Bolt M10x130
28	YK20F.V3-28	Bushing
29	SS1016.S	Hex Head Set Screw M10 X 16 Zinc
30	YK20FAH.30	Reservoir
31	YK20FAH.31	Pump Assy

Item	Part No.	Description
32	YK20FAH.32	Ring
33	YK20FAH.33	Small Pump Cylinder
34	YK20FAH.34	Ring
35	SA316.10	O-Ring, (Ex: 12.83 In: 7.59 Cs: 2.62)
36	YK20FAH.36	Nylon Ring
37	YK20FAH.37	Small Pumping Piston
38	YK20FAH.38	Handle Bracket
39	YK20FAH.39	Air Inlet Filter
40	YK20FAH.40	Air Valve
41	YK20FAH.41	Release Valve
42	YK20FAH.42	Ring
43	YK509FAH.51A	Air Pump
44	YK20FAH.44	R-Clip
45	YK20FAH.45	Tie Rod
46	YK20FAH.46	Air Hose
47	YK20FAH.47	Pin
48	YK30F.27	Handle
49	YK20FAH.49	Bolt
50	YK20FAH.50	Plate
51	SN10.SD	Steel Nut M10 Domed
52	YK20FAH.52	Hydraulic Hose
53	YK20FAH.53	Screw
54	YK20FAH.54	Sealing Ring
55	YK20FAH.55	Oil Filler Nut
56	YK20FAH.56	Nylon Ring
57	YK20FAH.57	Hose Fitting
58	YK20FAH.58	Connection Nut
59	YK20FAH.R15	Gauge Coupler
59	YK509FAH.60	Deep Nut
60	YK20FAH.60	Brace
61	YK20FAH.61	Air Motor Plate

NOTE: It is our policy to continually improve products and as such we reserve the right to alter data, specifications and component parts without prior notice. There may be alternative versions of this product, please contact us should you require this information.

IMPORTANT: No liability is accepted for incorrect use of product. Spare parts must be fitted by a competent person

WARRANTY: Guarantee is 12 months from purchase date, proof of which will be required for any claim.

Sealey Group, Kempson Way, Suffolk Business Park, Bury St Edmunds, Suffolk. IP32 7AR



01284 757500



sales@sealey.co.uk



www.sealey.co.uk

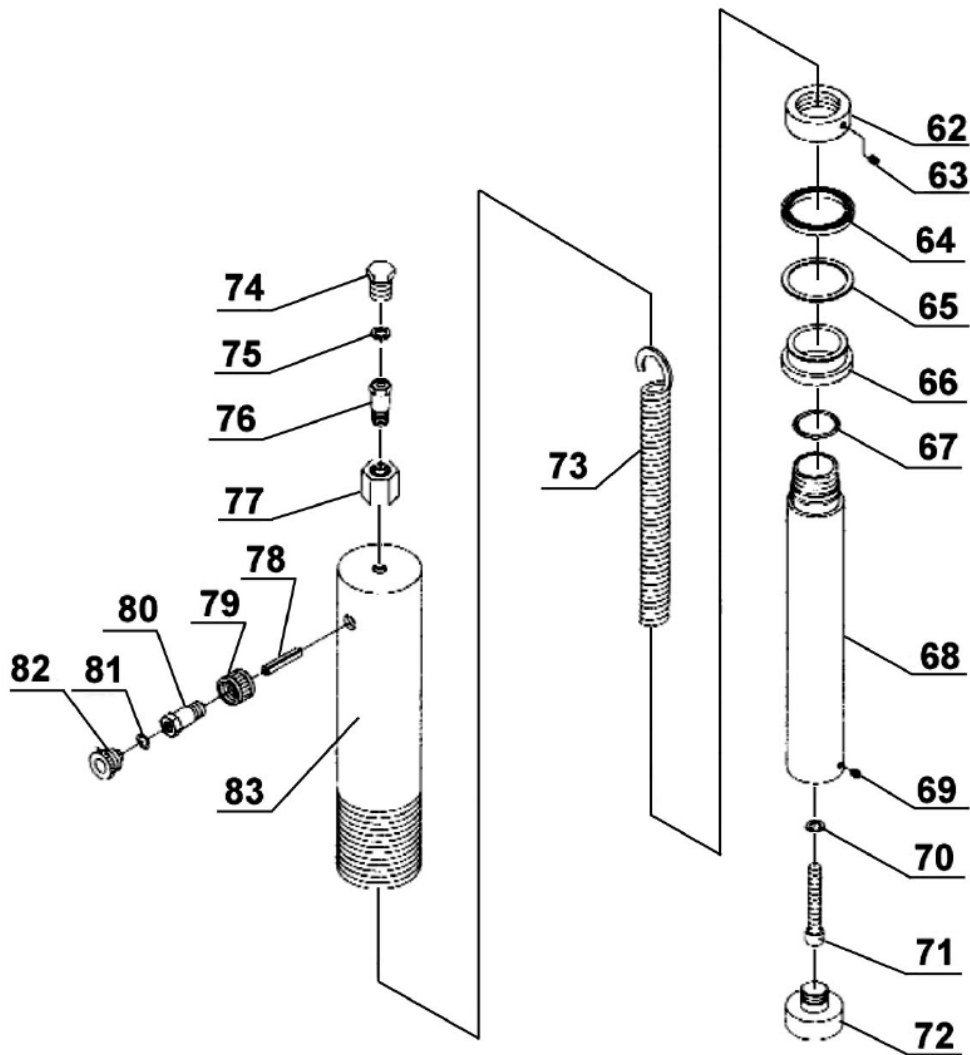

Item	Part No.	Description
62	YK20FAH.R01	Circular Nut
63	GSM66.S	Grub Screw M6x6
64	YK20FAH.R03	Seal Ring 50*60*6
65	YK20FAH.R04	Ring
66	YK20FAH.R05	Bushing
67	YK20FAH.R06	O-Ring, (Ex: 40.07 In: 33.97 Cs: 3.05)
68	YK20FAH.R07	Ram
69	YK20FAH.R08	Screw M6x10
70	YK20FAH.R09	Sealing Washer
71	YK20FAH.R10	Bolt M10
72	YK20FAH.R11	Toe
73	YK20FAH.R12	Spring Dia 29mm

Item	Part No.	Description
74	YK20FAH.R13	Screw
75	YK759FAH.61	Nylon Ring
76	YK20FAH.R15	Gauge Coupler
77	YK509FAH.60	Gauge Connection Nut
78	YK20FAH.R17	Spring Pin M10.6 X 50
79	YK20FAH.R18	Connection Nut
80	YK20FAH.R19	Coupler
81	YK20FAH.R20	O-Ring, (Ex: 14.08 In: 9.34 Cs: 2.37)
82	YK20FAH.R21	Dust Cap
83	YK20FAH.R22	Cylinder
--	YK20FAH.RC	Hydraulic Ram Complete.(Not Shown)

NOTE: It is our policy to continually improve products and as such we reserve the right to alter data, specifications and component parts without prior notice. There may be alternative versions of this product, please contact us should you require this information.

IMPORTANT: No liability is accepted for incorrect use of product. Spare parts must be fitted by a competent person

WARRANTY: Guarantee is 12 months from purchase date, proof of which will be required for any claim.