

Item	Part No.	Description
1	YK20F.V3-01	Pressure Gauge Btm Fitting'(Od 110mm)
2	YK759FAH.61	Nylon Ring
3	YK20FAH.RC	Hydraulic Ram Complete.
4	GSM66.S	Grub Screw M6x6 (Single)
5	YK30F.13	Saddle, Serrated (M) Ø 48mm (Shaft Ø 22mm)
6	YK20FAH.06	Round Nut, Upper Ring
7	YK20F.V3-07	Plate
8	YK20F.V3-08	Upper Nut
9	SS1635.S	Hex Head Set Screw M16 X 35 Zinc
10	YK20F.V3-10	Upper Beam
11	SN16.S	Steel Nut M16 Zinc
12	SWM16.S	Spring Washer M16 Zinc
13	FWM16.S	Flat Washer M16 Zinc
14	FWM10.S	Flat Washer M10 Zinc
15	SWM10.S	Spring Washer M10 Zinc

Item	Part No.	Description
16	SN10.S	Steel Nut M10 Zinc
17	YK20F.V3-17	V-Block (190x100x30)
18	YK20F.V3-18	Bed Frame
19	YK20F.V3-19	Pin, Table Support 250x25mm
20	YK20F.V2-20	Post
21	YK20F.V3-21	Base Section
22	FWM12.S	Flat Washer M12 Zinc
23	SWM12.S	Spring Washer M12 Zinc
24	SN12.S	Steel Nut M12 Zinc
25	SS1230.S	Hex Head Set Screw M12 X 30 Zinc
26	YK20F.V3-26	Lower support
27	HHB10130.S	Bolt M10x130
28	YK20F.V3-28	Bushing
29	YK20F.29	Screw M8x15
30	YK20F.30	Washer

NOTE: It is our policy to continually improve products and as such we reserve the right to alter data, specifications and component parts without prior notice. There may be alternative versions of this product, please contact us should you require this information.

IMPORTANT: No liability is accepted for incorrect use of product. Spare parts must be fitted by a competent person

WARRANTY: Guarantee is 12 months from purchase date, proof of which will be required for any claim.

Item	Part No.	Description
31	YK20FV3-31	Support Plate
32	YK20FV3-32	Pump ass'y
33	YK20FV3-33	Handle
34	YK20F.34	Oil Filler Nut
35	RE97.10-03	Hose Assembly
36	YK20F.36	Hose Fitting

Item	Part No.	Description
37	YK20FAH.R19	Coupler
38	YK20FAH.R15	Gauge Coupler
38	YK509FAH.60	Deep Nut
39	YK20FAH.60	Brace
--	YK20F.FK	Fixing Kit (Contains Nuts, Bolts etc.) (Not Shown)

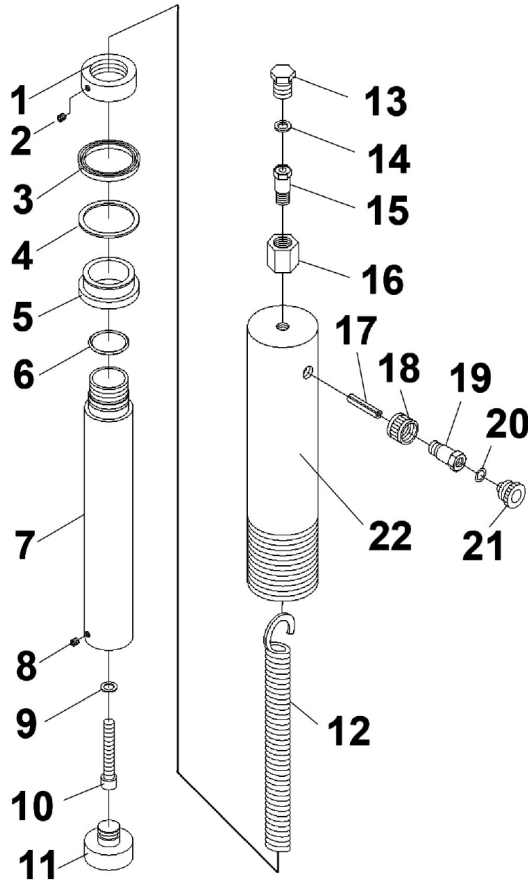

Item	Part No.	Description
1	YK20FAH.R01	Circular Nut
2	GSM66.S	Grub Screw M6x6
3	YK20FAH.R03	Seal Ring 50*60*6
4	YK20FAH.R04	Ring
5	YK20FAH.R05	Bushing
6	YK20FAH.R06	O-Ring, (Ex: 40.07 In: 33.97 Cs: 3.05)
7	YK20FAH.R07	Ram
8	YK20FAH.R08	Screw M6x10
9	YK20FAH.R09	Sealing Washer
10	YK20FAH.R10	Bolt M10
11	YK20FAH.R11	Toe
12	YK20FAH.R12	Spring Dia 29mm

Item	Part No.	Description
13	YK20FAH.R13	Screw
14	YK759FAH.61	Nylon Ring
15	YK20FAH.R15	Gauge Coupler
16	YK509FAH.60	Gauge Connection Nut
17	YK20FAH.R17	Spring Pin M10.6 X 50
18	YK20FAH.R18	Connection Nut
19	YK20FAH.R19	Coupler
20	YK20FAH.R20	O-Ring, (Ex: 14.08 In: 9.34 Cs: 2.37)
21	YK20FAH.R21	Dust Cap
22	YK20FAH.R22	Cylinder
--	YK20FAH.RC	Hydraulic Ram Complete.(Not Shown)

NOTE: It is our policy to continually improve products and as such we reserve the right to alter data, specifications and component parts without prior notice. There may be alternative versions of this product, please contact us should you require this information.

IMPORTANT: No liability is accepted for incorrect use of product. Spare parts must be fitted by a competent person

WARRANTY: Guarantee is 12 months from purchase date, proof of which will be required for any claim.