

Parts Information:
**Hydraulic Press 15 Tonne Floor Type with
 Foot Pedal**
Model No: YK15FFPV2

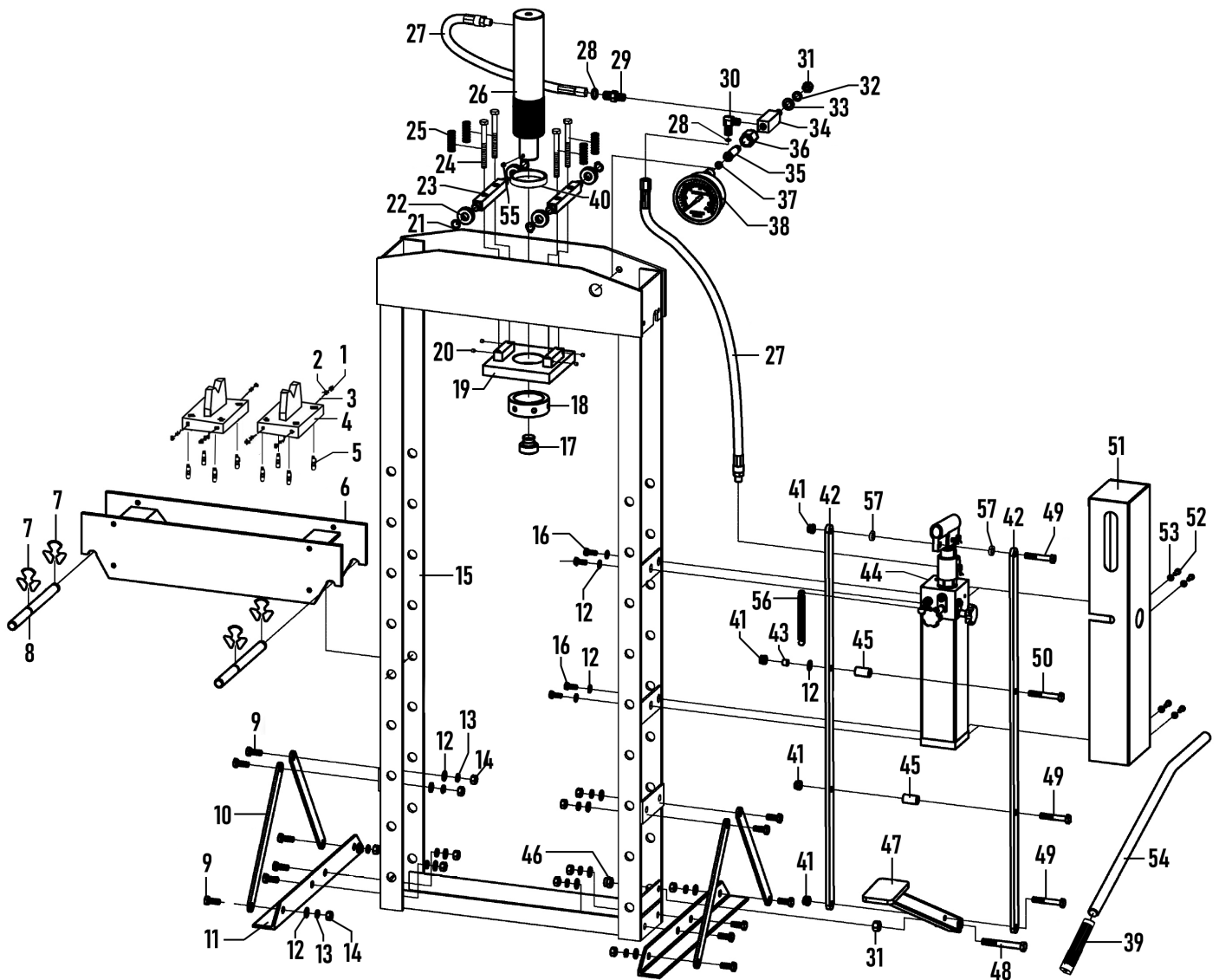

Item	Part No.	Description
1	GSM88.S	Grub Screw M8x8 (Single)
2	YK15FFPV2-02	Spring Dia 5mm
3	SB-5.6	Steel Ball 5.6mm
4	YK15FFPV2-04	V-Block
5	YK15FFPV2-05	Screw
6	YK15FFPV2-06	Bed Frame
7	YK15FFPV2-07	Retaining Clip
8	YK15FFPV2-08	Pin, Table Support 265x19mm
9	YK15FFPV2-09	Bolt
10	YK15FFPV2-10	Support
11	YK15FFPV2-11	Base Section
12	YK15FFPV2-12	Washer

Item	Part No.	Description
13	YK15FFPV2-13	Lock Washer
14	YK15FFPV2-14	Nut
15	YK15FFPV2-15	Frame
16	YK15FFPV2-16	Bolt
17	YK15FFPV2-17	Serrated Saddle
18	YK15FFPV2-18	Ram Nut
19	YK15FFPV2-19	Under Plate
20	YK15FFPV2-20	Screw
21	YK15FFPV2-21	R-Pin
22	YK15FFPV2-22	Slide Block
23	YK15FFPV2-23	Connecting Plate

NOTE: It is our policy to continually improve products and as such we reserve the right to alter data, specifications and component parts without prior notice. There may be alternative versions of this product, please contact us should you require this information.

IMPORTANT: No liability is accepted for incorrect use of product. Spare parts must be fitted by a competent person

WARRANTY: Guarantee is 12 months from purchase date, proof of which will be required for any claim.



Parts Information:
**Hydraulic Press 15 Tonne Floor Type with
Foot Pedal**
Model No: YK15FFPV2

Item	Part No.	Description
24	HHB10100.S	Hex Head Bolt M10 x 100mm
25	YK15FFPV2-25	Spring Dia 16.2mm
26	YK15FFPV2-26	Ram
27	YK15FFPV2-27	Oil Hose (For Ram) 20mm X 600mm
28	SA802.23	O-Ring, (Ex: 9.63 In: 6.07 Cs: 1.78)
29	YK15FFPV2-29	Joint
30	YK15FFPV2-30	Elbow Fitting
31	YK15FFPV2-31	Nut
32	YK15FFPV2-32	Lock Washer
33	YK15FFPV2-33	Washer
34	YK15FFPV2-34	Union Seat
35	YK15FFPV2-35	Union Screw
36	YK15FFPV2-36	Union Nut
37	YK15FFPV2-37	Nylon Ring
38	YK15FFPV2-38	Pressure Gauge
39	YK15FFPV2-39	Handle Grip
40	YK15FFPV2-40	Upper Round Nut

Item	Part No.	Description
41	YK15FFPV2-41	Nut
42	YK15FFPV2-42	Support
43	YK15FFPV2-43	Bushing
44	YK15FFPV2-44	Pump
45	YK15FFPV2-45	Bushing
46	YK15FFPV2-46	Nut
47	YK15FFPV2-47	Foot Pedal
48	HHB1290.S	Hex Head Bolt M12 x 90mm
49	YK15FFPV2-49	Bolt
50	YK15FFPV2-50	Bolt
51	YK15FFPV2-51	Protective Housing For Pump
52	YK15FFPV2-52	Screw
53	YK15FFPV2-53	Washer
54	YK15FFPV2-54	Handle
55	YK15FFPV2-55	Grub Screw
56	YK15FFPV2-56	Spring Dia 22.6mm
57	YK15FFPV2-57	Bushing

NOTE: It is our policy to continually improve products and as such we reserve the right to alter data, specifications and component parts without prior notice. There may be alternative versions of this product, please contact us should you require this information.

IMPORTANT: No liability is accepted for incorrect use of product. Spare parts must be fitted by a competent person

WARRANTY: Guarantee is 12 months from purchase date, proof of which will be required for any claim.

Sealey Group, Kempson Way, Suffolk Business Park, Bury St Edmunds, Suffolk. IP32 7AR



01284 757500



sales@sealey.co.uk



www.sealey.co.uk