

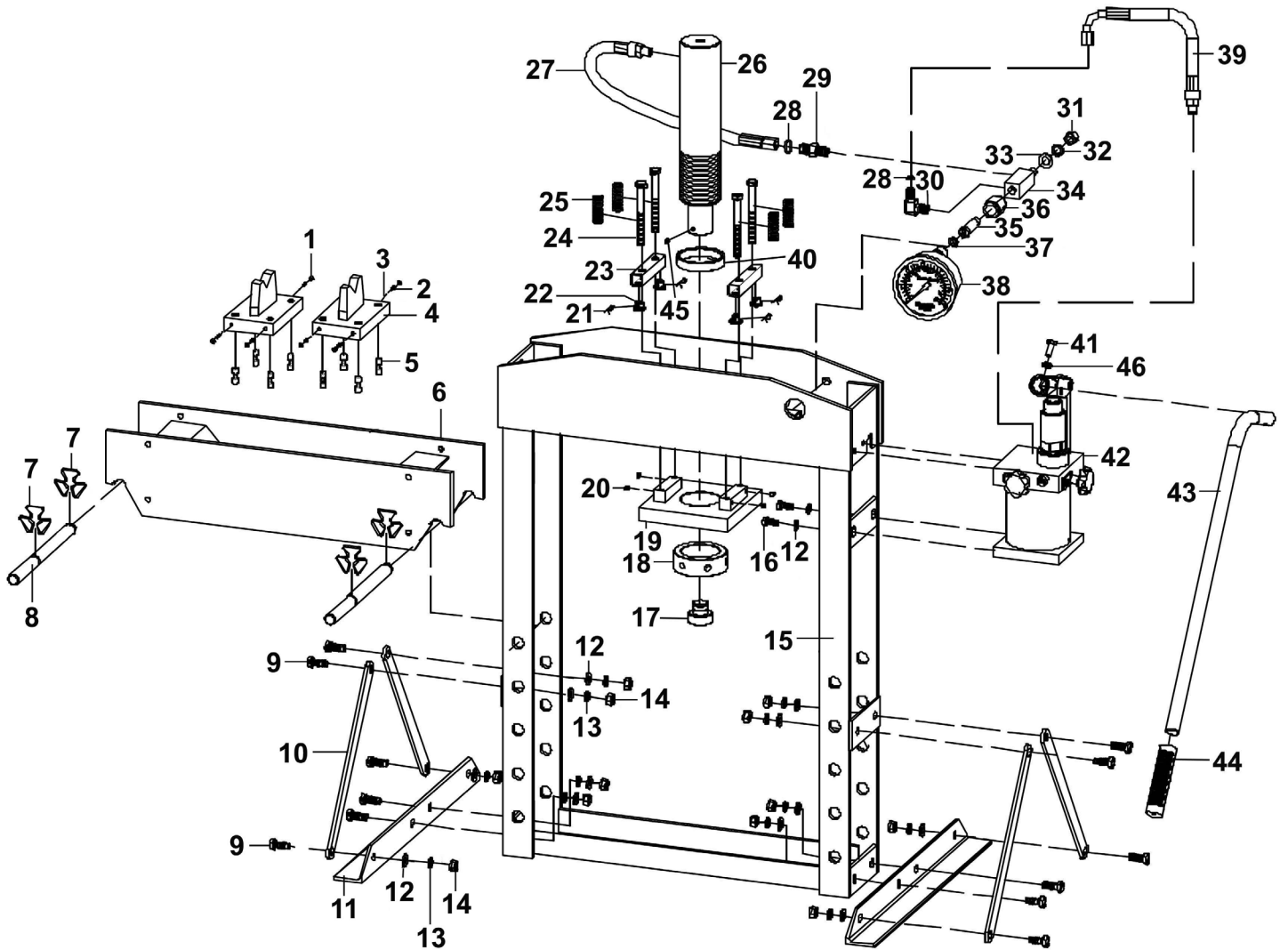

Parts Information:
Hydraulic Press Premier 15tonne Bench
Type
Model No: YK15BP.V2



NOTE: It is our policy to continually improve products and as such we reserve the right to alter data, specifications and component parts without prior notice. There may be alternative versions of this product, please contact us should you require this information.

IMPORTANT: No liability is accepted for incorrect use of product. Spare parts must be fitted by a competent person

WARRANTY: Guarantee is 12 months from purchase date, proof of which will be required for any claim.

Sealey Group, Kempson Way, Suffolk Business Park, Bury St Edmunds, Suffolk. IP32 7AR



01284 757500



01284 703534



sales@sealey.co.uk



www.sealey.co.uk



Parts Information:
**Hydraulic Press Premier 15tonne Bench
Type
Model No: YK15BP.V2**

Item	Part No.	Description
1	GSM88.S	Grub Screw M8x8 (Single)
2	YK15BP.V2-02	Spring Dia 5mm
3	SB-5.6	Steel Ball 5.6mm
4	YK15BP.V2-04	V-Block
5	YK15BP.V2-05	Screw
6	YK15BP.V2-06	Bed Frame
7	YK15BP.V2-07	Retaining Clip
8	YK15BP.V2-08	Pin, Table Support 265x19mm
9	YK15BP.V2-09	Bolt
10	YK15BP.V2-10	Support
11	YK15BP.V2-11	Base Section
12	YK15BP.V2-12	Washer
13	YK15BP.V2-13	Lock Washer
14	YK15BP.V2-14	Nut
15	YK15BP.V2-15	Frame
16	YK15BP.V2-16	Bolt
17	YK15BP.V2-17	Serrated Saddle
18	YK15BP.V2-18	Ram Nut
19	YK15BP.V2-19	Under Plate
20	YK15BP.V2-20	Screw
21	YK15BP.V2-21	R-Pin
22	YK15BP.V2-22	Slide Block
23	YK15BP.V2-23	Connecting Plate

Item	Part No.	Description
24	YK15BP.V2-24	Spring Dia 16.2mm
25	HHB10100.S	Hex Head Bolt M10 x 100mm
26	YK15BP.V2-26	Ram
27	YK15BP.V2-27	Oil Hose (for Ram) 20mm x 600mm
28	SA802.23	O-ring, (Ex: 9.63 In: 6.07 Cs: 1.78)
29	YK15BP.V2-29	Joint
30	YK15BP.V2-30	Elbow Fitting
31	YK15BP.V2-31	Nut
32	YK15BP.V2-32	Lock Washer
33	YK15BP.V2-33	Washer
34	YK15BP.V2-34	Union Seat
35	YK15BP.V2-35	Union Screw
36	YK15BP.V2-36	Union Nut
37	YK15BP.V2-37	Nylon Ring
38	YK15BP.V2-38	Pressure Gauge
39	YK15BP.V2-39	Oil Hose (for Pump) 15mm x 260mm
40	YK15BP.V2-40	Upper Round Nut
41	YK15BP.V2-41	Bolt
42	YK15BP.V2-42	Pump
43	YK15BP.V2-43	Handle
44	YK15BP.V2-44	Handle Grip
45	GSM68.S	Grub Screw M6x8 (Single)
46	YK15BP.V2-46	Washer

NOTE: It is our policy to continually improve products and as such we reserve the right to alter data, specifications and component parts without prior notice. There may be alternative versions of this product, please contact us should you require this information.

IMPORTANT: No liability is accepted for incorrect use of product. Spare parts must be fitted by a competent person

WARRANTY: Guarantee is 12 months from purchase date, proof of which will be required for any claim.

Sealey Group, Kempson Way, Suffolk Business Park, Bury St Edmunds, Suffolk. IP32 7AR



01284 757500



01284 703534



sales@sealey.co.uk



www.sealey.co.uk