

Parts Information:  
**Hydraulic Press 10tonne Economy Floor Type**  
**Model No: YK10ECF.V2**

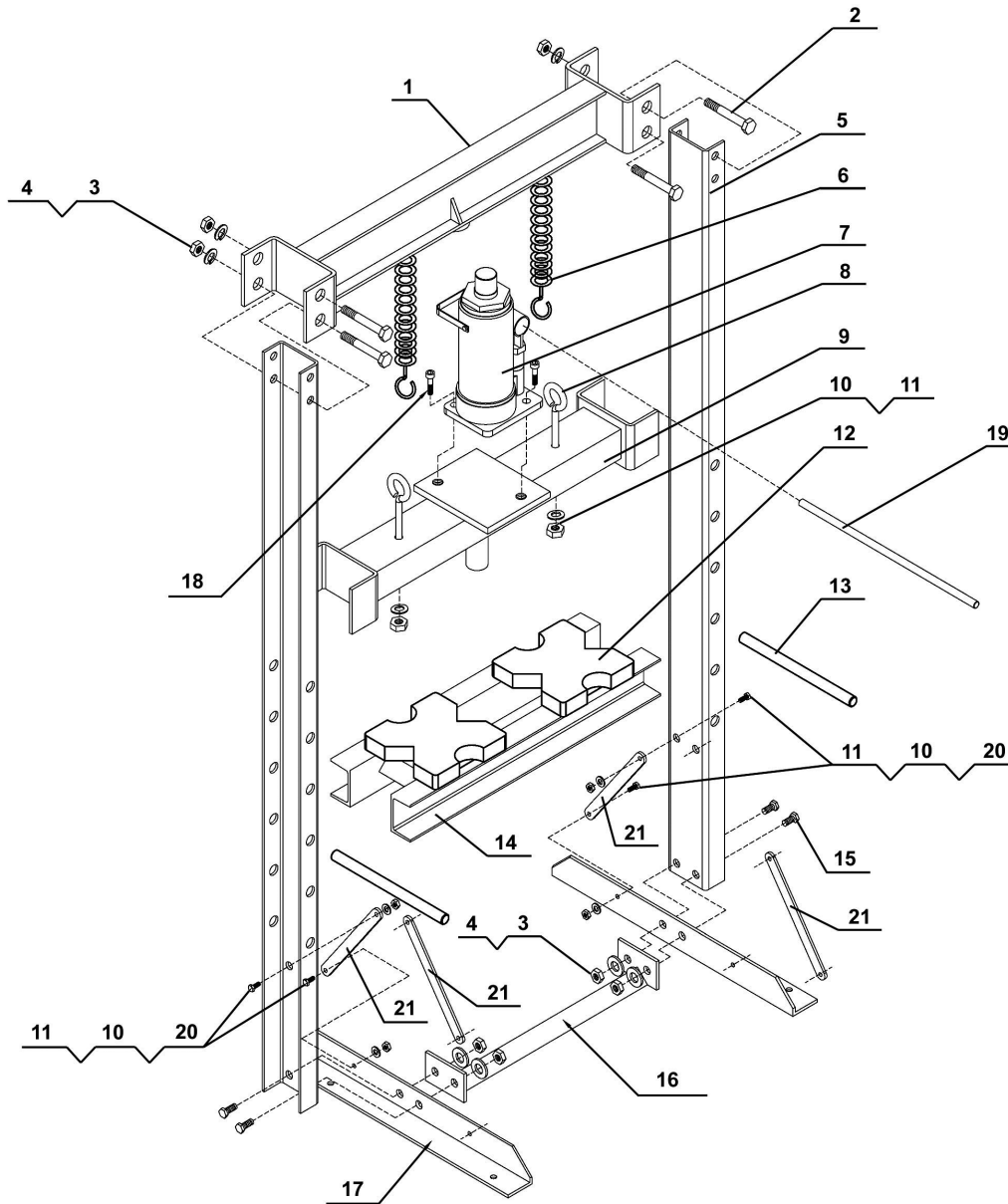

Item	Part No.	Description
1	YK10ECF.01	Upper Support
2	HHB12120.S	Hex Head Bolt M12 x 120mm
3	FWM12.S	Flat Washer M12 Zinc
4	SN12.S	Steel Nut M12 Zinc
5	YK10ECF.05	Upright
6	YK10ECF.06	Spring Dia 29.4mm
7	YK10ECF.07	Hydraulic Unit
8	YK10ECF.08	Hook Pin
9	YK10ECF.09	Support Plate
10	FWM8.S	Flat Washer M8 Zinc
11	SN8.S	Steel Nut M8 Zinc

Item	Part No.	Description
12	YK10ECF.12	Arbor Plate (150x150x25)
13	YK10ECF.13	Pin, Table Support 230x16mm
14	YK10ECF.14	Table
15	SS1230.S	Hex Head Set Screw M12 X 30 Zinc
16	YK10ECF.16	Base Support
17	YK10ECF.17	Foot
18	SCB816.SB	Socket Cap Bolt M8 x 16mm Black
19	YK20ECF.21	Handle
20	SS825.S	Hex Head Set Screw M8 X 25 Zinc
21	YK10ECF.21	Brace (280mm long)
--	YK10ECF.FK	Fixing kit

**NOTE:** It is our policy to continually improve products and as such we reserve the right to alter data, specifications and component parts without prior notice.

**IMPORTANT:** No liability is accepted for incorrect use of product.

**WARRANTY:** Guarantee is 12 months from purchase date, proof of which will be required for any claim.