

# 6" AIR ORBIT SANDER(5mm)

# CENTRAL- VACUUM

## Specifications

Pad Size..... 6" (146mm)  
 Free Speed..... 11000RPM  
 Average Air Consumption..... 112L/Min@0.63MPa  
 Air Inlet..... 1/4"

Recommended hose size..... 3/8" (I.D)  
 Working pressure ..... 0.63MPa  
 Air Exhaust..... Rear Exhaust

## Parts List

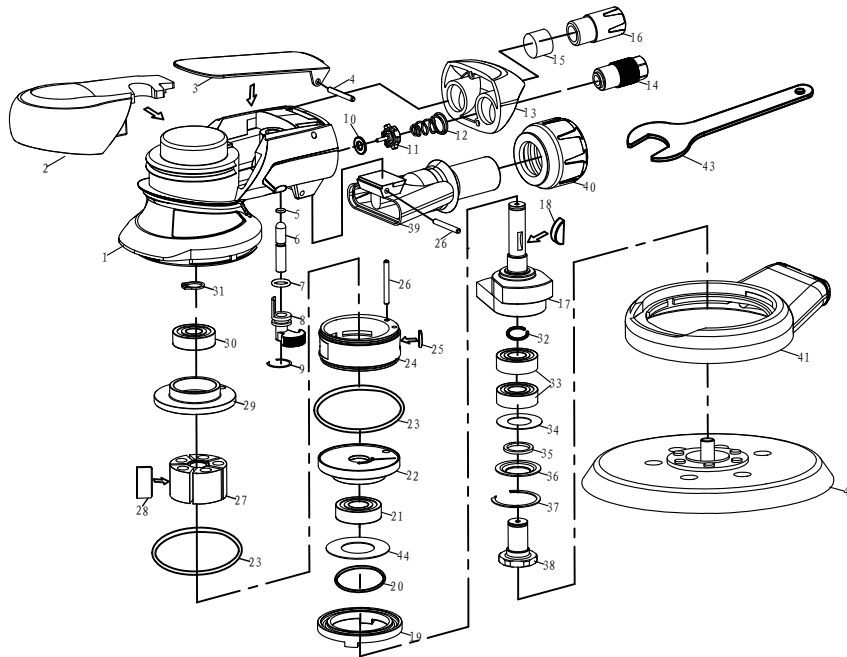

Ref.	Part#	Description	Q'TY
1	WFS-3638A-01	Housing	1
2	WFS-3638A-02	Jacket	1
3	WFS-3738-03	Lever	1
4	GB/T879.2-2000 3*45	Spring pin	1
5	JB/T 6659-2007 4*1	O-ring	1
6	WFS-3738-04	Pin	1
7	GB/T3452.1-1992 8*1.8	O-ring	1
8	WFS-3738-05	Regulator	1
9	WFS-3738-06	C retaining ring	1
10	WFS-1038A-06	Switch valve gasket	1
11	WFS-1038A-07	Switch	1
12	WFS-3738-07	Spring	1
13	WFS-3738-08	Tailstock	1
14	WFS-3738-09	Air inlet connector	1
15	WFS-3738D-06	Silencer cotton	1
16	WFS-3738D-02	Decorative cover	1
17	WFS-3938-03	Drive shaft	1
18	GB/T1099-1979 3*5*13	Woodruff key	1
19	WFS-3738-23	Lock ring	1
20	GB/T 3452.1-1992 39.8*3.1	O-ring	1
21	GB/T 276-1994 6001-2Z	Bearing	1
22	WFS-3738-11	Front cylinder head	1
23	O Ring 38*1.5	O-ring	2
24	WFS-3738-12	Cylinder	1
25	WFS-1038A-15	O-ring	1

Ref.	Part#	Description	Q'TY
26	GB/T879.2-2000 3*28	Spring pin	2
27	WFS-3738-22A	Rotor	1
28	WFS-3738-27	Blade	5
29	WFS-3738-13	Rear cylinder head	1
30	GB/T 276-1994 6000-2Z	Bearing	1
31	GB/T 894.1-1986 10	Retaining rin	1
32	GB/T 895.2-1986 12	Snap Ring	1
33	GB/T 276-1994 6001-RS	Bearing	2
34	WFS-3738-14	Dustproof pad	1
35	WFS-1038A-19	Sealing ring	1
36	WFS-3738-15	Washer	1
37	WFS-1038A-21	C retaining ring	1
38	WFS-3738-21	Balancing shaft	1
39	WFS-3738E-01	Vacuum adapter	1
40	WFS-3738-17	Suction Joint	1
41	WFS-3738-18	Dust collecting hood	1
42	WFS-3638B-01	6" PAD	1
43	WFS-1038A-26	Spanner	1
44	WFS-3738-25A	Dustproof	1