

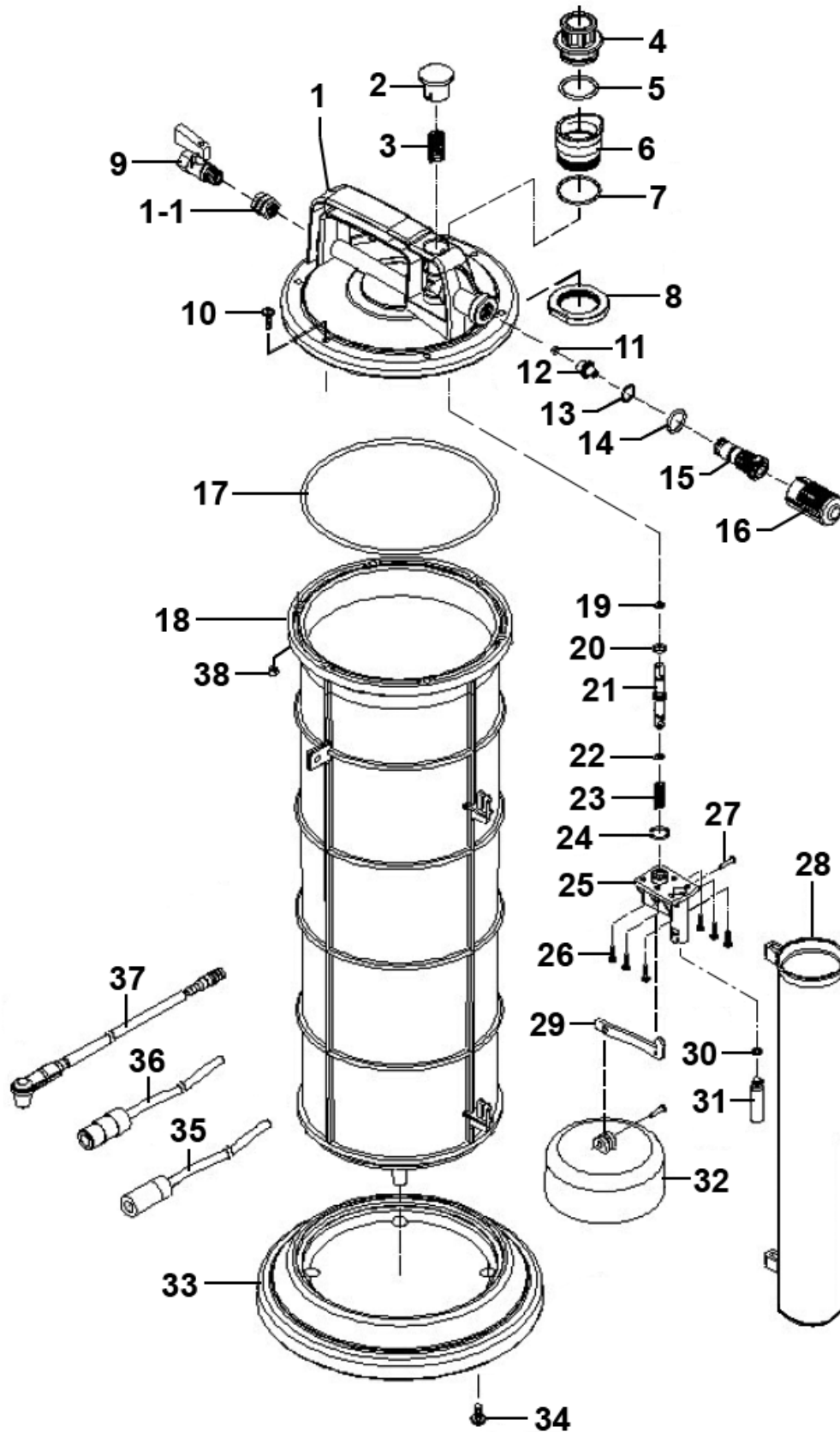

Parts Information:
Vacuum Oil & Fluid Extractor Air Operated
9ltr
Model No: TP6903



NOTE: It is our policy to continually improve products and as such we reserve the right to alter data, specifications and component parts without prior notice. There may be alternative versions of this product, please contact us should you require this information.

IMPORTANT: No liability is accepted for incorrect use of product. Spare parts must be fitted by a competent person

WARRANTY: Guarantee is 12 months from purchase date, proof of which will be required for any claim.

Sealey Group, Kempson Way, Suffolk Business Park, Bury St Edmunds, Suffolk. IP32 7AR



01284 757500



01284 703534



sales@sealey.co.uk



www.sealey.co.uk



Parts Information:
**Vacuum Oil & Fluid Extractor Air Operated
9ltr
Model No: TP6903**

Item	Part No.	Description
1	TP6903.V2-01	Cover Housing
1-1	TP6903.V2-01A	Insert Nut
2	TP6903.V2-02	Push Button
3	TP6903.V2-03	Spring Dia 12.9mm
4	TP6903.V2-04	Fluid Inlet Coupler
5	TP6901.V2-05	O-Ring, (Ex: 29.26 In: 26.64 Cs: 2.62)
6	TP6901.V2-06	Fluid Outlet Housing
7	TP6901.V2-07	O-Ring, (Ex: 28.71 In: 25.15 Cs: 1.54)
8	TP6901.V2-08	Lock Nut
9	TP6903.V2-09	Air Valve
10	MSP520.SB	Machine Screw Pan Head Phillips M5x20mm Black
11	TP6903.V2-11	O-Ring, (Ex: 8.51 In: 5.45 Cs: 1.53)
12	TP6903.V2-12	Vacuum Valve
13	TP6903.V2-13	O-Ring, (Ex: 15.20 In: 11.14 Cs: 2.03)
14	VS3900.03	O-Ring, (Ex: 17.56 In: 14 Cs: 1.78)
15	TP6903.V2-15	Vacuum Body
16	TP6903.V2-16	Muffler Shell Assembly
17	TP6901.V2-17	O-Ring, (Ex: 159.05 In: 151.99 Cs: 3.53)
18	TP6901.V2-18	Reservoir Tank
19	SA912.V2-04	O-Ring, (Ex: 7.24 In: 3.68 Cs: 1.78)

Item	Part No.	Description
20	SA802.23	O-Ring, (Ex: 9.63 In: 6.07 Cs: 1.78)
21	TP6903.V2-21	Shaft
22	SA912.V2-04	O-Ring, (Ex: 7.24 In: 3.68 Cs: 1.78)
23	TP6903.V2-23	Spring Dia 11.2mm
24	VS3900.03	O-Ring, (Ex: 17.56 In: 14 Cs: 1.78)
25	TP6903.V2-25	Safety Valve Housing
26	TP6901.V2-20	Screw 3.8x10mm
27	TP6901.V2-19	Pin
28	TP6901.V2-22	Tube Storage Unit
29	TP6903.V2-29	Arm
30	SA77S.V4-19	O-Ring, (Ex: 8.03 In: 4.47 Cs: 1.78)
31	TP6903.V2-31	Safety Cup
32	TP6901.V2-21	Float
33	TP6903.V2-33	Base
34	TP6901.V2-24	Rd Head S/T Screw M6 X 15
35	TP6901.V2-45	Main Suction Tube (c/w Adaptor) 10mm x 1120mm
36	TP6901.V2-46	Extracting Tube (c/w Adaptor) 6mm x 1120mm
37	TP6903.V2-37	Brake Tube (c/w Rubber Fitting)
38	SN5.SB	Steel Nut M5 Black

NOTE: It is our policy to continually improve products and as such we reserve the right to alter data, specifications and component parts without prior notice. There may be alternative versions of this product, please contact us should you require this information.

IMPORTANT: No liability is accepted for incorrect use of product. Spare parts must be fitted by a competent person

WARRANTY: Guarantee is 12 months from purchase date, proof of which will be required for any claim.

Sealey Group, Kempson Way, Suffolk Business Park, Bury St Edmunds, Suffolk. IP32 7AR



01284 757500



01284 703534



sales@sealey.co.uk



www.sealey.co.uk